

Automatic Cognition System Design using Microprocessor

Si-hwan Kim¹, Chi-ho Lin¹, Young Huh², Hi-seok Kim³

¹Dept. of Computer Science, Semyung University.

²Korea Electrotechnology Research Institute

³Dept. of Electronic Engineering, Chongju University.

Tel. +82-43-649-1272, FAX. +82-43-649-1272

E-mail: godson2@unitel.co.kr, ich410@semyung.ac.kr, yhuh@keri.co.kr, khs8391@chongju.ac.kr

Abstract: This paper proposes the system that automatically cognizes the external interface cards on control board.

This system is proposed by this paper endows with ID to external interface card and cognizes a connection of external interface card.

Also this system automatically executes a task for external interface card.

This system has an extension of function according to cognize an external interface card and is fast the execution.

1. Introduction

Automation technology had changed with a development of computer and communications. By development of skill development, quality was improved gradually. Also, consumer's request becomes various and automation in industrial society be-came serious. It is trend that skill development of factory automation is propelled by research educational system enemy including electricity electronic engineering, mechanical engineering, computer engineering etc. and the application extent is extended continuously along with development of pointed end New Technology field by intelligence anger of automation skill.

Current domestic industry is facing to urgency castle of type skill development by factor of international competitiveness enfeeblement and transfer of technical know-how escaping of advanced nation and opening markets pressure etc [1-3].

This paper explained basic technique that design manufacture of automatic cognition systems, and analyzed state of error in automatic movement cognition ability of manufactured system and transmission level of data. Therefore, The system can cognize automatically an external interface card or devices, and is used for purpose of device that connect by connection external interface card. Made to have signal of only devices and define the signal and make protocol to cognize external devices for this automatically.

This paper is explained about automatic cognition system and construct of control board system in chapter 2, and layout and implementation of system in chapter 3, and

an experiment and analysis for verify action of system in chapter 4, and show conclusion and hereafter research a subject in chapter 5.

2. Automation interface system

The configuration of control board system is proposed by this paper consisted to a main controller and many external device systems.

Put RAM for storage of a program that is analyzed signal that main controller is send to external device.

And Main Controller has a MPU which analyze a signal is sent from external Interface card and was consisted of 8255 PPI(Programmable Peripheral Interface) to device about datum and input/output signal. External device part allowed display to come MPU that can pass own information on main controller part and do own work.

The Action of this system sees in figure 1, First MPU 1 send a signal for connection information of external board, to MPU 2 through serial port. Second MPU 2 on the Main Controller analyze serial signal that send to MPU 1. In that case MPU 2 return a signal 'MPU 2 was connected to MPU 1' to MPU 1 through serial port again. The Main Controller finds out a kind of external board through analysis of serial data and sends a data signal for action of external board. The signal of action of external board is transmitted by 8255 PPI to 8bit Parallel data.

The External Board executes to itself using data that receive Main Controller.

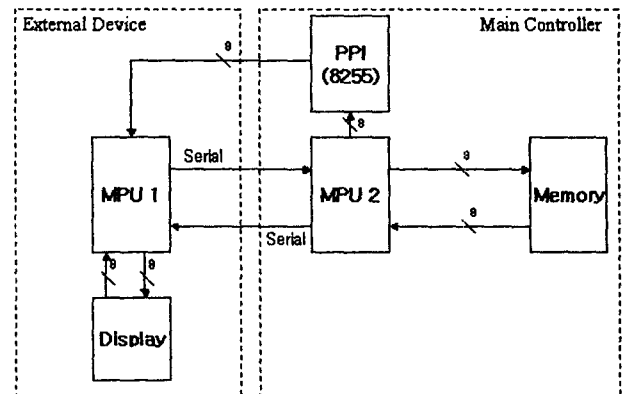

* This work was supported by the RRC program of MOST and KOSEF

Figure 1. Automatic cognition system structure

Explanation about operating state, Figure 2 is a static diagram that is shown behavior state of system. (S0) state wait until receive signal from external interface card. If signal happens in external interface cards, it analyzes receiving signal in (S1) state. After analyze signal in (S1) state, State change to (S2) state. (S2) state find a task correspond to each external interface card. Here (S3), (S4) (S5) state is shown a task correspond to each external interface card.

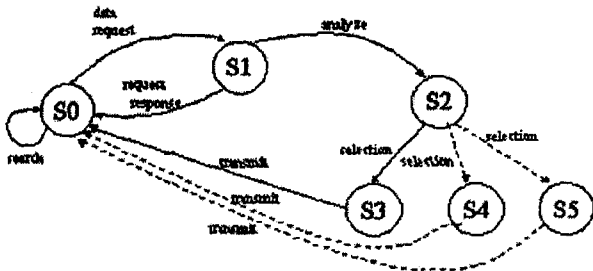

Figure 2. Operating state

Between each external Interface cards and main controller need to a communication protocol, which use to cognition external interface card.

Fig. 3 shows a communication protocol structure between main controller and external interface card.

Trans data structure has a data structure of 32bits and divides into each 4 data. STX is header of protocol and ETX is end of protocol. Check Sum is the 8bits data that check a error at communication. Value of check sum has an addition value of STX and DATA.

The DATA is a byte contains information of each external interface board. Send data structures was achieved by 4 bytes, and receive data structure was achieved by 3 bytes.

Trans Data Structure

STX	Data	Check sum.	ETX
STX: Transm start direct.			
Data: Machine information.			
Check sum: Error check.			
ETX: Transm stop direct.			

Receive Data Structure

STX	ACK	ETX
STX: Receive start direct.		
ACK: Response start direct.		
ETX: Receive stop direct.		

Figure 3. Protocol structure of external device

DATA of Send Data Structure in Fig. 3 includes information of external interface card.

Fig. 4 shows the bit information to DATA. Each bit value means an information external interface card.

If analyze data that consist by 1 byte, information structure of device appears as see in figure 4. 3 bits defined that is request address part of data because information of data that external device need has been stored from first 0 bits to 2 bits in 8 bits. The 4th bit did justice about to be going to speak low rank instruction if is going to speak high position instruction in control instruction for communication. From fifth bit to eighth bit, is defining that device confidence is some device as ID of each external device. This has consisted by 4 bits and can define external device of 16 guns.

Send data to external device that analyze in main control device and require structure of figure 4 below.

External device that receive data has correct action.

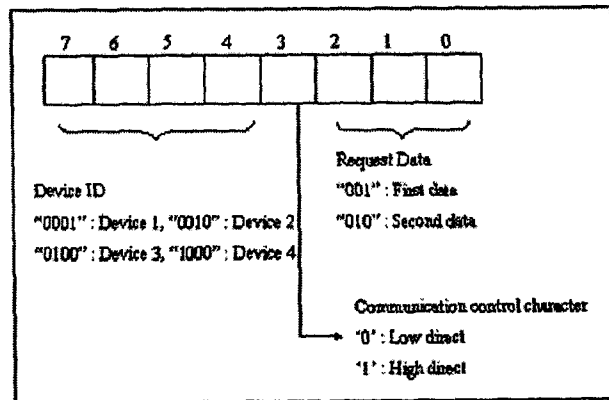

Figure 4. Information structure of board

Is same with figure 5 if see flowing of system action that propose in this paper. First, if interrupt signal enters, it analyzes interrupt signal. Analysis analyzes ID of external device first time and this is corresponded to eighth bit from fifth in information structure of board. If single external device was realized, this to analyze request data is corresponded to the 3rd bit from 1st of information structure of board. If all analysis finished, send again request data to external device that it corresponds to him. Sent data processes in external device and is executed. But, because new external device does connection while send data to external device interrupt data that is transmitting item many sides stop and analyze new signal. According to connection availability of external device, with figure 5, get into circulatory flow.

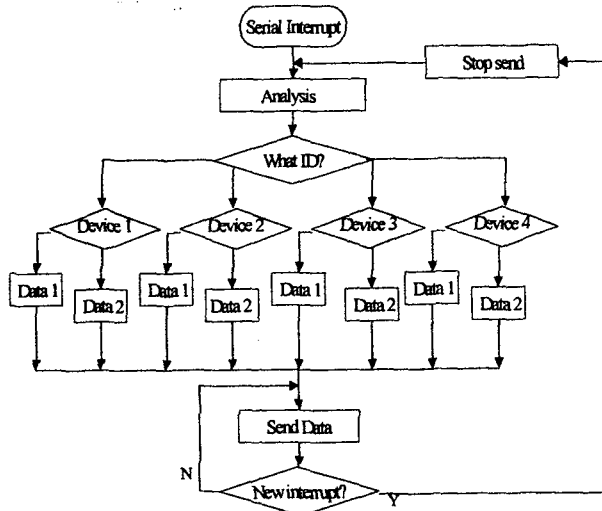

Figure 5. Flowchart for system action

Figure 6 proposed function part that process parts that process information of external device at analysis step of flowchart for system action.

If serial interrupt signal enters first time, it receives data and do analysis. Analysis did processing to Switch case function. Main board can grasp that signal that send in serve board wants some data and can transmit data that the device requires by doing this.

```

void serial_interrupt()
{
    int i = each_Data();
}

void send_Data(char Data)
{
    switch (Data)
    case Wait 1 : Wait 1 (Data);
        break;
    case Wait 2 : Wait 2 (Data);
        break;
    case Wait 3 : Wait 3 (Data);
        break;
    case Wait 4 : Wait 4 (Data);
        break;
}

```

Figure 6. Analysis step processing function

3. Layout and implementation of interface automation system

The microprocessor of main board in this paper used 8051 of Intel and ROM used 27C64, and RAM is 62256, and I/O interface chip be used 8255 PPI. Used 8051 of Intel with main board and external interface board, and altered display kind according to own work kind. This paper planned display part using 7 segments each coming dot to do beginner comprehensibly.

Planned circuit diagram from state that collection of enough data and verification for design of these control board are completed to work of first step. Can know flow of actual program composition of circuit diagram is completed and is because programming becomes available according to it.

Below figure 7 is designed by OR CAD 9.0 as circuit diagram of actuality control board.

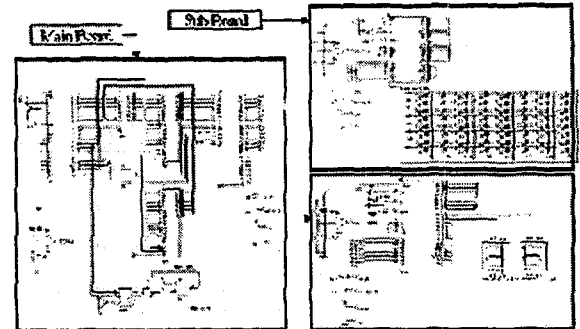

Figure 7. Design circuit diagram

4. An experiment and verification

Experiment in this control board analyzed that correct value of data was sent through electrical transmission.

Through this experiment, can confirm that data to serve board was transmitted exactly in main board.

Control board that use in verification has component part such as below figure 8.

Selection language: System C
 CPU: 89C55, 89C2051
 Others: 8255 PPI, 14pin connector

Figure 8. Elements for implementation of control board

Put concrete block of transmission, reception, and channel for correct verification of data. Channel is convex that act as middle when send data from transfer to reception. Have created data piece to send from sending to in coming by first if see in figure 9. In the next receive data packet field of fill. Put serial numbers on PKT and transmit packet to channel. Serial numbers offers unique consistency of data packet so that correct response packet may can be transmitted. Channel does random number action of transmission medium to do modeling noise adds.

Quantity of noise does dependence in type of transmission module that becomes modeling. If device block that receive from device number and reception convex that send from transmission block is same, can see that agree with data value that it creates first time becoming display.

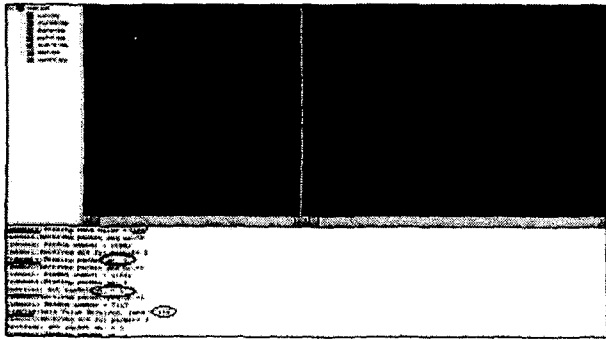

Figure 9. Timing chart

- [8] Burd, Tomas D., *Energy Efficient Microprocessor Design*, October 10
 [9] Ball, Stuart R., *Embedded Microprocessor Systems*, May 2000

5. Conclusion

Circuit design in this paper is designed that has a minimum of composition. So development may be easy. Also, equipment of system executes a fast and correct action because it is implemented to external interface automatic cognition system. Define a protocol contain own information in external interface showed possibility that can make one standard in development of control board. Can know that have softness and high extensity by developing different necessary devices according to suitable element.

If control system includes RTOS then product has more development of technique.

Also, this control system enables implementation not board level but in chip level. In accordance with Operating System by possible in chip level which board level is not is expected that extension of specification system offers easy and to maintenance etc. Fair convenience fairly.

Reference

- [1] Esther M.Aleman, *Automated Schematic Capture and the UCS51*, presented at the IEEE ASIC Seminar, New York, September 25-28, 1987.
 [2] Intel Corporation, *Cell-Based Design Procedures Mentor Environment*, Intel corporation, 1987.
 [3] Intel Corporation, *Automation of Core-Based Design Construction*, Intel corporation, 1989.
 [4] Politecnico di Torino, Magenti Mare-lli, *HW/SW Co-Design for Embedded Systems*, March 1995.
 [5] Charles M.Gilmore Jamex L., "Antonakos Principles and Application 2E", March 2001
 [6] John D. Lenk, *Simplified Design of Microprocessor-Supervisory Circuit*, April 1998
 [7] Tom Shanley, *Plug and Play System Architecture*, August 1995