

A Study on Improvement of Controller Performance using Intelligent Control Method

Seung-Sun Yoo*, Moon-Seong Kim**, Chi-Ho In***, Hoon-Sung Kwak*

*Dept. of Image Information Engineering, Chonbuk National University

**Dept. of Computer Information and Communication, Daewon Science College

***Dept. of Computer Science, Semyung University

Tel : +82-043-649-3219

E-mail : yss2590@hanmir.com*, kms@daewon.ac.kr**, ich410@semyung.ac.kr***

ABSTRACT

In this paper, by comparing the performance of HVAC(Heating Ventilating and Air Conditioning) by the typical PI(Proportional Integral) control and the HVAC by the new neural network control, it will show the applicability of neural network control algorithm to HVAC of buildings. These show that neural network system that can respond to changes in temperature and system can replace PI control that has been conventionally used in buildings.

1. Introduction

Generally speaking, the functions of automation technique for building facility system are divided into supervision function and control function. The purpose of efficient automation technique for building facility system is to minimize the use of the energy for HVAC while not deteriorating pleasantness of living conditions[1][2].

Many automated buildings of nowadays are using HVAC by PI that has simple and solid characteristics. However, to keep up good performance, a proper tuning is necessary. The operation of tuning not only requires time and expense but is hard to implement where it has robust non-linear or large delay time. Even after tuning, re-tuning is necessary due to deterioration of control performance by non-linear or time variable property[3][4].

By comparing the performance of HVAC by PI and the HVAC by neural network control, it will show the applicability of neural network control algorithm

to HVAC of buildings.

The last experiment was done at a testing house, which had actual operating HVAC system. Operator can change the artificial weather condition manually. Proposed system showed that PID controller can be supplemented. In addition output control signal was improved in fast responsiveness and tracking controlling.

2. Control theory

Basic controllers used in the industry are On-off controllers and PID controllers, and fuzzy controllers and neural controllers have started being used recently. This chapter reviews the basic operation of the PID controller and the neural network controller used in this research[5][6].

2.1 PID control theory.

Shown below is the equation of a PID controller combining proportional control action, integral control action and derivative control action.

$$u(t) = K \left[e(t) + \frac{1}{T_i} \int_0^t e(\tau) d\tau + T_d \frac{de(t)}{dt} \right]$$
$$= K_P + K_I + K_D$$

u : control variable

e : control error

K : proportional gain

T_i : integral time

T_d : derivate time

K_P : proportional term for error

K_I : proportional term for integral of error

K_D : proportional term for derivate of error

2.2 Neural network control theory.

A neural network circuit, a parallel machine that has many elements working together, is a system that does software and hardware parallel distributed processing, similar to that of data in human brain. It is a characteristic of a neural network circuit that it is a MIMO concept control method that can take multiple input parameters from input layer and produce a multiple output, by which it can overcome the shortcoming of conventional one output from one input method[7].

Important components of a neural network circuit are neurons and connections between them. Composition of a neuron is shown in Fig. 1.

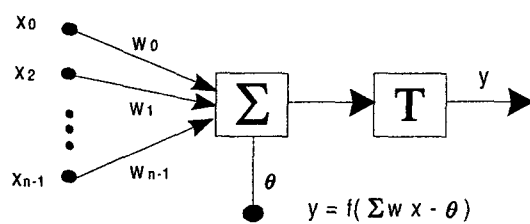

Fig. 1 Configuration of neuron

The sum of the all the input weight against every connectivity W_{ij} that a neuron takes as input from other neuron's output X_i is

$$Net_j = \sum_{i=0}^n W_{ij} X_i$$

The result of the above formula will be sent to other neuron connected to this neuron as an output.

$$Y_j = F\left(\sum_{i=0}^n Net_j + \theta_j\right)$$

W_{ij} is connectivity between i_{th} neuron and j_{th} neuron, X_i is i_{th} input, and θ_j is j_{th} neuron's bias value.

3. System Analysis

3.1 Modeling

(1) Building Modeling

Analytic research is performed on non-ondol room in the test house. The capacity of this non-ondol room is $50m^3(6.9m \times 3m \times 2.4m)$ and this room has two $1.5m \times 1.5m$ windows.

Since the amount of the thermal conduction through building material and window is big portion of the building's thermal load, the close examination of the structure and array of the building's cover, and the building material's thermal characteristics is very important. Building materials of the test house in environment chamber are grouped into outer wall, inner wall dividing between sections, floor and ceiling, and based on the plan of the building, every part's material and object property value is convert into similar material that has same object property value in TRNSYS PREBID. They are shown in Table 1.

Table 1. Wall layer and thickness

Wall Name	Layer Material	Thickness (mm)	Conductivity (kJ/hmK)	Capacity (kJ/kgK)
External	Red brick	90	2.55	0.84
	Urea form	50	0.13	0.04
	Cement brick	190	5.44	0.84
	Mortar	5	5.04	1.0
Internal	Mortar	5	5.04	1.0
	Concrete	120	7.756	1.0
	Mortar	5	5.04	1.0
Bottom	Concrete	120	7.756	1.0
Top	Concrete	120	7.756	1.0
	Urea form	80	0.13	0.04
	Air layer	650	0.047	-
	Gypsum plaster	5	0.54	1.2
Window	U-Value : 1.4 W/m ² K			

(2) System Modeling

The outline of the HVAC selected for analytical research is Fig. 2. This picture shows that the air comes in through air inhalation fan, passes through heating coil and flows into each zone. It's structure is: the air used in this zone is exhausted through a circulation fan. Some will be exhausted and some will inflow through damper.

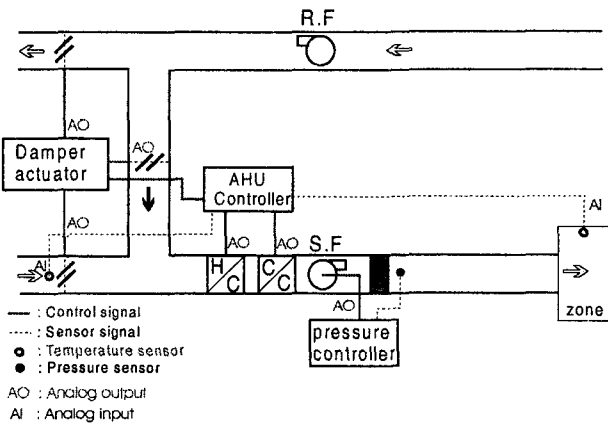

Fig. 2 Circuit of conditioning system

3.2 TRNSYS programming

TRNSYS program, developed by the University of Wisconsin and used to analyze dynamic energy interpretation of builds, is used in this research for the dynamic interpretation of indoor space. Since TRNSYS program does not have PID control or neural network control, they were programmed and modularized.

To interpret the system's performance, the system design (Fig. 2) is composed to TRNSYS programming environment. It is shown in Fig. 3.

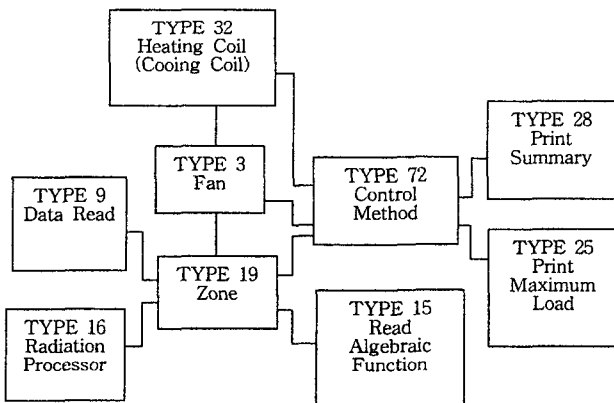

Fig. 3 Flow chart of TRNSYS programming

4. System simulation using NN

4.1 Temperature tracking using NN

As a building HVAC control method to fix limiting problems of PI control and to maximize the system performance, neural network controlling is used.

For this simulation, basic input layer is generated for using in the neural network controller based on the data acquired from the PI control using TRNSYS.

The simulation is done with temperature set to 22°C, 27°C, and 2°C, and time interval set to 1.7 and 2.5 hours, that are same as used in PI control to compare with PI control.

The simulation of both winter and summer is conducted. In input layer, the data of both summer and winter are included, leaving input layer against outdoor temperature is not used. Fig. 4 is a temperature tracking graph of summer air-conditioning when neural network is in use, and Fig. 5 is a temperature tracking graph of winter heating when neural network is in use.

Fig. 4 and Fig. 5 show that a controller using neural network can control temperature as accurate as PI control. In addition, using the data value acquired from this, it can be inferred that an intelligent temperature control that reacts to the change in the system and temperature by itself is possible.

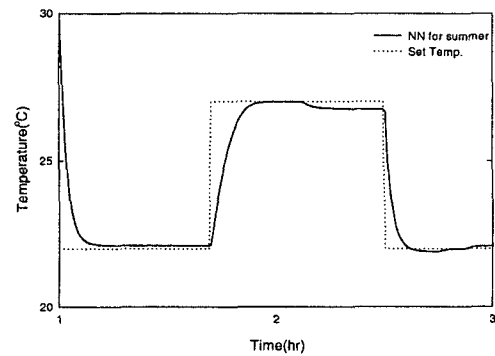

Fig. 4 Time vs. temperature in summer (NN Control)

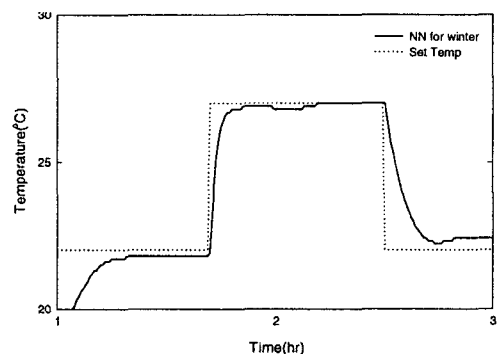

Fig. 5 Time vs. temperature in winter (NN Control)

4.2 Comparison of PI and NN control

Fig. 6 is a comparison graph of summer neural network control and PI control to show temperature tracking. In the graph, when the air influx is

1000kg/hr, temperature tracking by PI control and temperature tracking by neural network are almost same. Hence, it can be inferred that neural network control can satisfy the temperature tracking by PI control.

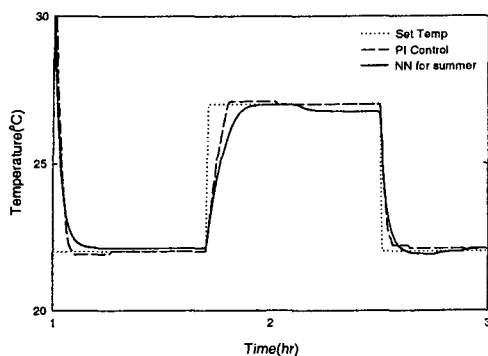

Fig. 6 Time vs. temperature in summer (PI and NN Control)

Fig. 7 is a comparison graph of winter neural network control and PI control to show temperature tracking. In the graph, when the air influx is 1000kg/hr, temperature tracking by PI control and temperature tracking by neural network are almost same.

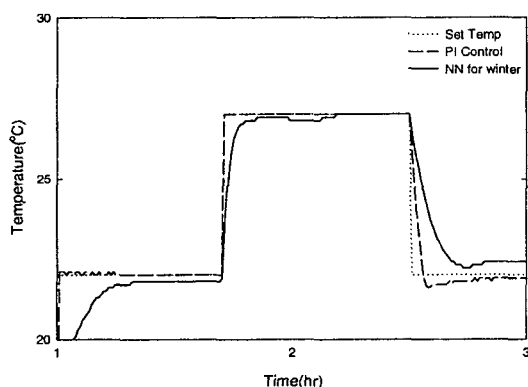

Fig. 7 Time vs. temperature in winter (PI and NN Control)

5. Conclusions

In this paper, the characteristics of PI control, that is commonly used in controlling of an air-condition of buildings is reviewed, and the possibility of using one of the intelligent control system, neural network is examined.

From the above theoretic study, next conclusions can be inferred.

1. When the change of the temperature is big, as it is in Korea, adjusting the gain value of PI controller

properly can maximize the system's operation.

2. By using the intelligent control system such as neural network, the result similar to using PI control can be achieved, and the shortcoming of PI that it is necessary to set the gain value when the outside temperature changes does not exist.

3. In air-conditioning system, neural network solves the problem in PI control that requires time to get the optimal gain value and the energy consumption in consequence. However, it can be inferred that, to optimize the neural network system, the improvement of learning rate by providing learning data and setting the hidden unit count properly, should be accompanied to keep the neural network system in optimal condition.

These show that neural network system that can respond to changes in temperature and system can replace PI control that has been conventionally used in buildings.

References

- [1] J. E. Braun and T. M. Ross, "Minimizing Operating Costs of Vapor Compression Equipment with Optimal Service Schedule", *International Journal of Heating, Ventilating Air Conditioning and Refrigerating Research*, 2(1), pp. 23-47, 1996.
- [2] J. Hyvarinen, "Real Time Simulation of HVAC System for Building Optimization", *Fault Detection and Diagnosis Source Book, IEA ANNEX 25, VTT*, 1996.
- [3] HANG, C. C., LIM, C. C., and SOON, S. H., "A new PID auto-tuner design based on correlation technique" *Proceedings 2nd Multinational Instrumentation Conference, China*, 1986.
- [4] J. E. Bekker, P. H. Meckl, and D. C. Hittle, "Tuning Method for First-Order Processes With PI Controllers", *Proceedings of ASHRAE*, pp. 19-23, 1991.
- [5] Doyle, J. C., Francis, B. A., and Tannenbaum, A. R., "Feedback Control Theory", Macmillan, New York, 1992.
- [6] G. S. Virk and D. L. Loveday, "A Comparison of Predictive, PID and On/Off Techniques for Energy Management and Control", *Proceedings of ASHRAE*, pp. 3-10, 1992.
- [7] S. J. Hepworth and A. L. Dexter, "Neural control of a non-linear HVAC plant", *Proceedings 3rd IEEE Conference on Control Applications*, 1994.