

Development of Induction Heated Hot Water Producer using Soft Switching PWM High Frequency Inverter

Kentarou Fujita, Serguei Moisseev, Laknath Gamage, Sarawouth Chandhaket,
Hidekazu Muraoka, Mutsuo Nakaoka

Department of Electrical and Electronics Engineering, The Graduate School of Science and Engineering, Yamaguchi University, Japan
Tokiwadai, 2-16-1, Ube, Yamaguchi, 755-8611, Japan

Abstract - This paper presents a new conceptual electromagnetic induction eddy current-based stainless steel plate spiral type heater for heat exchanger or Dual Packs Heater in hot water producer, boiler steamer and super heated steamer, which is more suitable and acceptable for new generation consumer power applications. In addition, an active clamped edge-resonant PWM high frequency inverter using trench gate IGBTs power module can operate under a principle of zero voltage soft commutation with PWM is developed and demonstrated for a high efficient induction heated hot water producer and boiler in the consumer power applications. This consumer induction heater power appliance using active clamp soft switching PWM high-frequency inverter is evaluated and discussed on the basis of the simulation and experimental results.

Keywords High Frequency Inverter, Edge-Resonant Soft Switching PWM, Duty Cycle Control, Induction Heated Steamer Dual Packs Heater, Consumer Power Electronics

1 Introduction

In recent years, electromagnetic induction eddy current-based heat energy processing and utilization systems using a variety of the high frequency high-power inverters have attracted special interest from the view points of high efficiency, high reliability, safety, cleanliness, compactness in volumetric size, light in weight, rapid temperature response for particular high power applications in industry automotive and consumer fields. This paper presents a new conceptual energy saving type electromagnetic eddy current-based induction heater, which is more suitable and acceptable for induction heated hot water producer, boiler and steamer. On the other hands, active voltage clamped type zero voltage soft switching PWM high frequency inverter connected to utility AC200V-RMS for consumer power applications is developed and demonstrated from a practical point of view. In this paper, a new style compact induction heated hot water producer and steamer using soft switching PWM high frequency inverter is also discussed and evaluated from the experimental and simulation points of view.

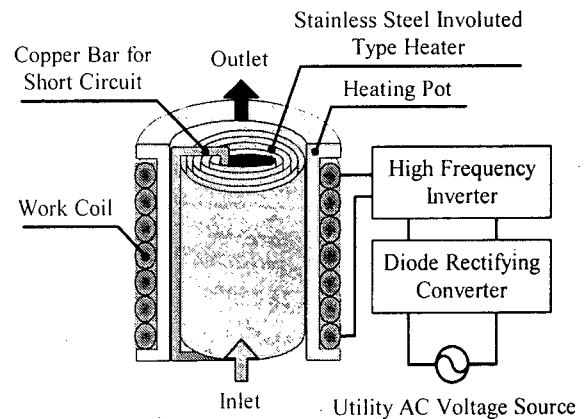

Fig.1 Induction heated hot water producer

2 Induction Eddy Current-based Heated Hot Water Producer

A prototype of the induction eddy current-based heated hot water producer and steamer is schematically illustrated in Fig.1. This energy conversion device on the basis of an electromagnetic induction-heated type heat exchanger composed of the Dual Packs Heater is made of a new conceptual induction heater which is built and tested by spiral stainless steel assembly, working coil (litz wire), non metal heating vessel made of the polycarbonate, high frequency soft-switching inverter using IGBTs and diode rectifying converter.

3 New Conceptual Induction Heater

An electromagnetic induction heater for compact hot water producer and steamer using high frequency inverter driven by the diode rectifier with a non smoothing filter has to be designed for the following requirements: (a) uniform temperature distribution, (b) wide eddy current heating surface, (d) no erosion, (e) no thermal deformation for power injection or rejection, (f) small heat capacity. In this paper, a new conceptual induction heater made of non-magnetic stainless steel SUS316 plate is demonstrated that has a spiral assembly with a short circuit called copper bar end ring for quick temperature response in specified temperature setting. It is composed of the spiral assembly

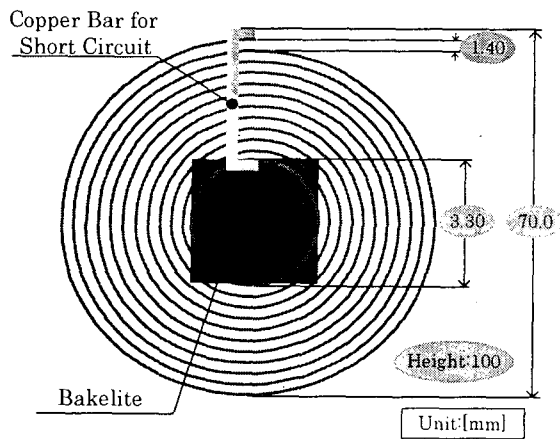

Fig.2 Top view appearance of electromagnetic induction eddy current-based heater

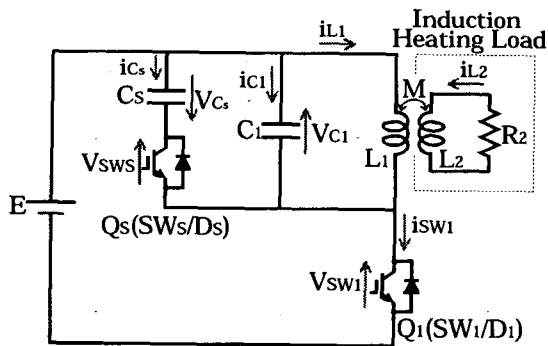
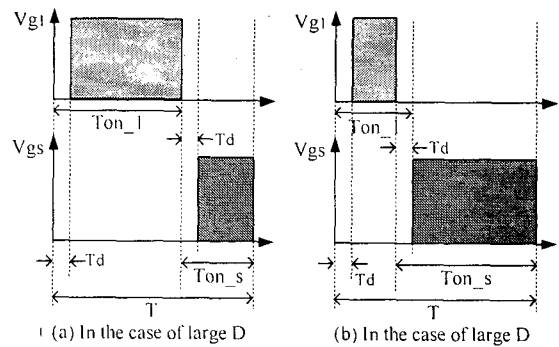

Fig.3 Active voltage clamped edge resonant high-frequency inverter

and its outside edge point is connected to the inside edge point by connecting the low resistance copper bar between two edge point. In this technique, it is possible to achieve a uniform temperature distribution of an electromagnetic induction eddy current-based joule's induction heated type heat exchanger.

In general, it is difficult to form the spiral structure toward its center. In case of rolling toward its center, effective increment of heating surface could not expect actually. But if no obstacle is inserted in the center of the spiral plate structure, heat exchange efficiency of this induction heater decreases because a large majority of the heated liquid flows through the center. To improve reduced heat exchange efficiency, the cylindrical polycarbonate material is inserted toward the center of this vessel. The geometric size and shape of this induction heater is designed as illustrated in Fig.2.



(a) In the case of large D
(b) In the case of large D
Vg1 : Gate pulse for SW₁
Vgs : Gate pulse for SW_s
T : One cycle time for high frequency inverter
Ton_l : Conduction time for SW₁
Ton_s : Conduction time for SW_s
Td : Dead time
D : DutyFactor (=Ton_l/T)

Fig.4 Asymmetrical PWM gate voltage pulse signal sequences

4 Active Clamping Quasi-Resonant ZVS PWM High Frequency Inverter

4.1 Circuit Description

Figure.3 shows an active clamp high frequency inverter circuit topology that can operate under a condition of zero voltage soft switching (ZVS) and constant frequency duty factor regulated mode: asymmetrical pulse width modulation (PWM) control strategy for power regulation. This active voltage clamp high frequency inverter using IGBTs, which has some advantageous points such as wide soft switching operation range, low peak voltage stress for power switching devices and high efficiency, which is developed and implemented for electromagnetic induction eddy current-based heated hot water producer and steamer and boiler. Introducing the voltage clamped capacitor (C_s) in series with an auxiliary active power switch, this high frequency inverter can effectively clamp an excessive peak voltage applied to the main active power switch (SW_1). Besides introducing auxiliary switch (SW_s), this high frequency inverter can operate under a constant frequency asymmetrical pulse width modulation (PWM) control strategy. In Fig.3, this induction heated hot water producer driven by this inverter is represented as the transformer type equivalent circuit model.

4.2 Gate Pulse Control Implementation

Figure.4 illustrates timing asymmetrical PWM pulse sequences for the high frequency inverter shown in Fig.3. These voltages pulses are supplied to the power semiconductor switching block; Q_1 (SW_1/D_1) and Q_s (SW_s/D_s). Duty Factor defined as $D = t_{on}/T$ serves as a control variable for the continuous power regulation for this edge-resonant soft switching PWM inverter using IGBTs. Duty Factor is designed as a ratio of the conduction time

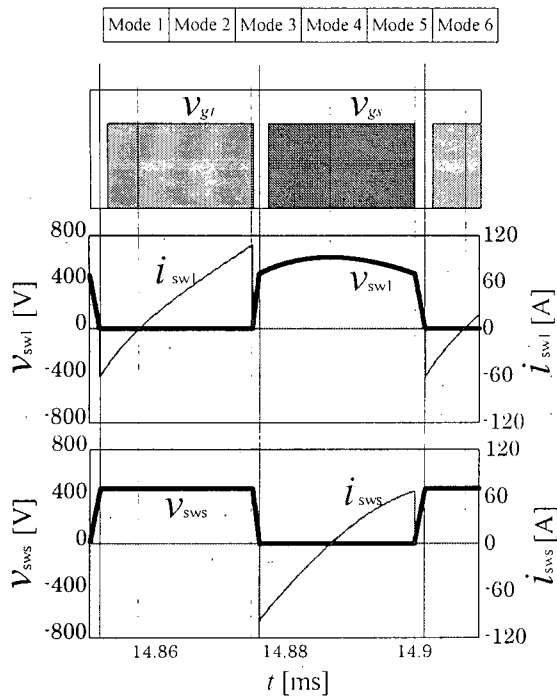

Fig.5 Steady-state switching waveforms

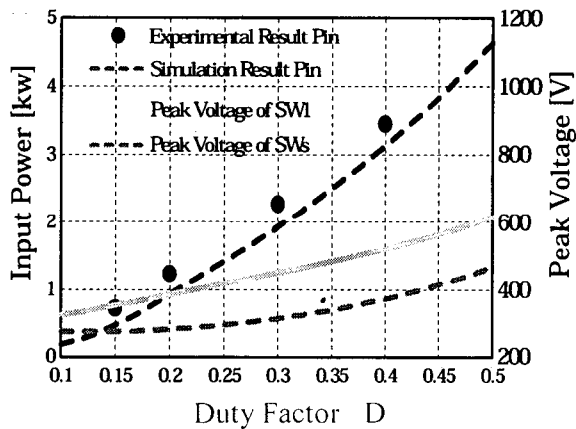

Fig.6 Duty factor vs. input power and peak voltage characteristics

including a dead time of the main active power switches during one period.

When the full power is delivered to the load, the conduction time of the main active power switch during one cycle is lengthened as indicated in Fig.4 (a). On the other hand, when the full power is not required for load, the conduction interval is shortened as indicated in Fig.4 (b).

4.3 Switching Voltage and Current Waveforms

Figure.5 shows the steady-state switching voltage and current simulation waveforms of Q_1 (SW_1 & D_1) and Q_s (SW_s & D_s) under the zero voltage soft switching condition with $D=0.5$. In Fig5, both of the main active power switch

Table.1 Design specification

Item	Symbol	Parameter Value
DC Source Voltage	E	200[V]
Switching Frequency	f	20[kHz]
Edge-Resonant Lossless Capacitor	C_l	0.18[μ F]
Active Voltage Clamped Capacitor	C_s	3.96[μ F]
Working Coil	L_l	50.9[μ H]
Electromagnetic Coupling Coefficient	k	0.693
Load Time Constant	τ	9.63[μ S]

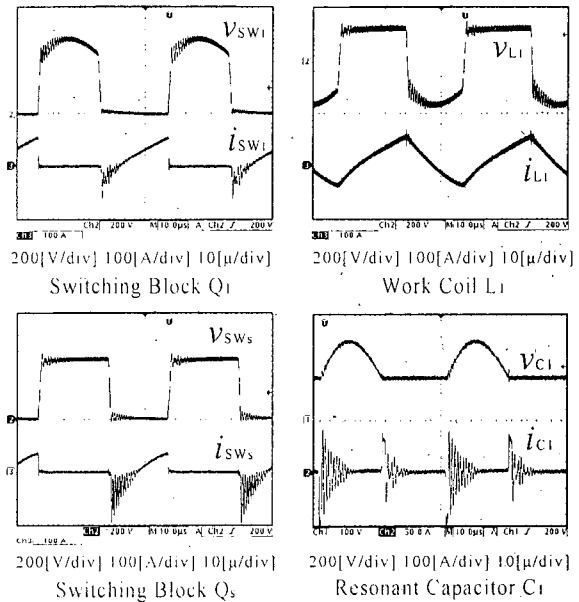

Fig.7 Experimental voltage and current waveforms (Duty Factor $D = 0.5$)

and the auxiliary active power switch can achieve soft switching completely. Besides, this active voltage clamp high frequency load resonant inverter can suppress an excessive peak voltage applied to the main active power switch for Mode3 and Mode4. This high frequency inverter in steady-state includes periodically repeated operation with 6 modes. Fig.6 represents Duty Factor vs. input power regulation characteristics and Duty Factor vs. peak voltage characteristics for a new prototype of induction heating energy conversion device under a constant frequency asymmetrical PWM control strategy. Observing this Fig.6, it is clearly proved that the inverter output power can be continuously adjusted in the accordance with Duty Factor or Duty Cycle D as a control variable.

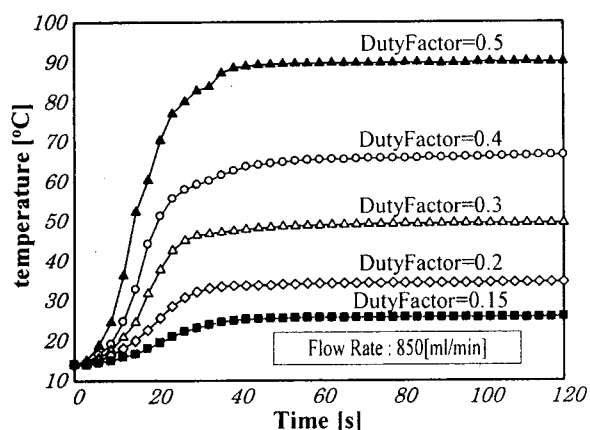

Fig.8 Fluid temperature response characteristics of IH hot water producer and steamer

5 Experimental Results and Discussions

5.1 Design of Experimentally produced Hot Water Producer

Table.1 indicates the practical design specifications and circuit parameters of the feasible electromagnetic induction based heated hot water producer and steamer using edge-resonant ZVS-PWM soft switching high frequency load resonant inverter using the IGBT modules.

5.2 Observed Waveforms

Figure.7 illustrates the steady-state observed switching voltage and current waveforms of Q_1 (SW_1 & D_1), Q_5 (SW_5 & D_5), L_1 and C_1 under the specified condition of Duty Cycle $D=0.5$. Besides, it is proved that this active clamp edge-resonant ZVS-PWM high frequency inverter using IGBTs can completely work under the operating principle of zero voltage soft switching commutation for a wide duty factor control scheme. This active clamped edge-resonant high frequency inverter can limit an excessive peak voltage applied to the main active power switch. Accordingly, the conduction power losses as well as voltage and current peak or dynamic derivative stresses of switching power semiconductor devices; IGBTs can be considerably reduced in this high frequency inverter circuit topology.

5.3 Temperature Characteristics

Figure.8 illustrates temperature response characteristics of the induction heated hot water producer and steamer composed of specially designed spiral type induction heater using active voltage clamp high frequency inverter which is built and tested in experiment. It is noted that this inverter type compact induction heated hot water producer and steamer using new conceptual electromagnetic induction eddy current-based heater in pipeline systems can heat rapidly than conventional gas combustion type or sheathed

wired heating type.

6. Conclusions

In this paper, the novel prototype of electromagnetic induction eddy current-based hot water producer and steamer using active clamp high frequency quasi-resonant inverter has been successfully proposed and demonstrated from a practical point of view. In addition, an active voltage clamped edge-resonant ZVS-PWM high frequency load resonant inverter using the latest trench IGBT module, which can efficiently operate under a zero voltage soft commutation on the basis of asymmetrical PWM (Duty Ratio Control) strategy. This induction heated appliances for pipeline fluid heating using active voltage clamp edge-resonant high frequency inverter could be more cost effective than the conventional gas combustion heating type or sheathed wired heating type.

In the future, the power loss analysis of this soft-switching high frequency inverter using the CSTBTs in new generation should be done for consumer induction-heated hot water producer and boiler, and steamer as well as super heated steamer in pipeline systems.

References

- [1] Y.S.Kwon, B.K.Lee, S.B.Yoo, D.S.Hyun "Half Bridge Series Resonant Inverter for Induction Cooking Applications with Load-Adaptive PFM Control Strategy", Proceedings of International conference on power electronics - Seoul, pp10183-1023, October, 1998
- [2] Y.Ohnishi, Y.Tsujii, H.Noijima "Development of the Induction water Heating System", IEEJ-National Convention, March, 1999
- [3] T.Kouda, S.Kondoh "Development of electromagnetic induction heater for heated hot water producer", IEEJ-Kansai Section convention on Electrical and Electronics, ppG148, November, 2000
- [4] H.Tanaka, H.Sadakata, H.Muraoka, A.Okuno, E.Hiraki, M.Nakaoka "Innovative Electromagnetic Induction Eddy Current-based Far Infrared Rays Radiant Heater using Soft Switching PWM Inverter with Duty Cycle Control Scheme", Proceedings of International conference on power electronics - Seoul, pp64-68, October, 2001