

Recent Sensor-less Vector Control of Induction Motor Applied for Electric Railway Vehicles in Japan

Ichiro Miyashita and Hyun Woo Lee

Kyungnam University, Technical Innovation Center for Production Automation

Recent trend of sensor-less control of induction motor applied for commuter trains in Japan is introduced. Although many inverter-fed induction motor driven trains have been produced so far, most of them were slip frequency based conventional V/f control system using shaft encoder.

There arises a new trend to apply speed sensor-less vector control., for this inverter-fed induction motor drive system. The purpose of sensor-less control is to save, cost and improve system reliability. Several sensor-less systems now under testing on the actual railway company.

This paper describes the survey of the fundamental structure and feature of representative sensor-less systems mentioned above.

1. Introduction

More than ten years ago, inverter fed induction motor traction drive system has been widely used for train service operation in many country of the world.

Not only AC induction motor has no need to maintenance of the commutator and brush like DC motor, but also it has light weight, which makes the dynamic performance excellent. So, almost all recent newly built trains are adopt inverter and induction motor coupled system. Vector control is now in the period of maturity.

For these some years, a new trial to realize Speed Sensor-less Vector Control System has been developed for these traction drive system, mainly in Europe and Japan. Speed sensor-less vector control is sometimes called "sensor-less control" in short. This does not mean that either current or voltage sensor is removed.

Why sensor-less vector control should be needed? Speed sensor is very important component because it is the tact of inverter operating frequency. The reason to remove the speed sensor is explained as follows.

- 1) From the viewpoint of system reliability, the failure of speed sensor including the noise signal from its

wiring can cause a serious breakdown.

- 2) Speed sensor for traction motor is very low resolution of pulse. Because it is attached to the shaft end inside the end bracket, minute encoder like as industrial servo motor cannot be available due to its bad conditions such as mechanical vibration and oil mist and etc.
- 3) Vector controller cannot display so much excellent performance because of low resolution speed sensor.
- 4) If the speed sensor is removed from the shaft end of the traction motor, the motor output capacity may be increased by extending the core length of traction motor. The actual core length is restricted by the rail width.

2. Some Methodology of Sensor-less Vector Control for Traction Drive

In industrial and servo drive system many sensor-less control algorithm has been proposed and utilized, But, roughly speaking, they are classified to two large categories.

The first one is the direct calculation type. In this type, rotor speed is directly calculated by explicit formula expressed by instantaneous vector equations.

The second one is adoptive speed estimation method based on MRAS. In this method, rotor speed is estimated by the converged value of PI controller of state error.

This paper describes several actual example proposed and tested by some manufacturing companies.

2.1 Direct speed calculation method ^{(1), (2)}

Fig. 1 shows the block diagram of direct speed calculation method. In this method, motor speed is calculated by subtracting slip frequency from rotor flux rotating frequency. The rotor flux is calculated by following equations.

$$\Psi_2 = \int \frac{L_2}{M} (\dot{v}_1 - R_1 i_1) dt - \left(\frac{L_1 L_2}{M} - M \right) i_1 \quad (2.1)$$

Here, the rotor flux, voltage, and current vector components $\Psi_{2\alpha}, \Psi_{2\beta}, v_{1\alpha}, v_{1\beta}, i_{1\alpha}, i_{1\beta}$ are the variables in the stationary $\alpha\beta$ axes. Then the rotor frequency is written by following equations.

$$\omega_2 = \frac{d}{dt} \left(\tan^{-1} \frac{\Psi_{2\alpha}}{\Psi_{2\beta}} \right) \quad (2.2)$$

$$\omega_m = \omega_2 - \omega_s \quad (2.3)$$

$$\omega_s = R_2 \frac{M(\Psi_{2\alpha} i_{2\beta} - \Psi_{2\beta} i_{2\alpha})}{L_2(\Psi_{2\alpha}^2 + \Psi_{2\beta}^2)} \quad (2.4)$$

Note these calculation does not contain the rotatory to stationary axes transformation. motor speed ω_m can be calculated instantaneously without any delay caused by speed control loop dynamics. This method has very quick and stable response. But it is affected by motor parameters directly, it is used combining a motor parameter measuring system.

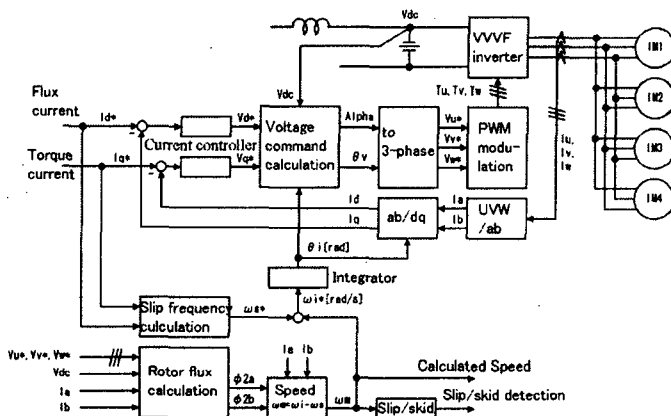

Fig.1 Direct speed calculation method

2.2 Speed estimation method by torque component current feedback ⁽³⁾

Fig. 2 shows the speed estimation method by torque component current feedback method. This method has a pair of current regulator, named z-ACR and q-ACR, respectively. Here, q-ACR estimates rotor speed operating the quantity equivalent to induced motor voltage

In the sensor-less vector control of railway vehicles, Starting at moving toward reverse direction is difficult problem, because at that instant inverter frequency passing

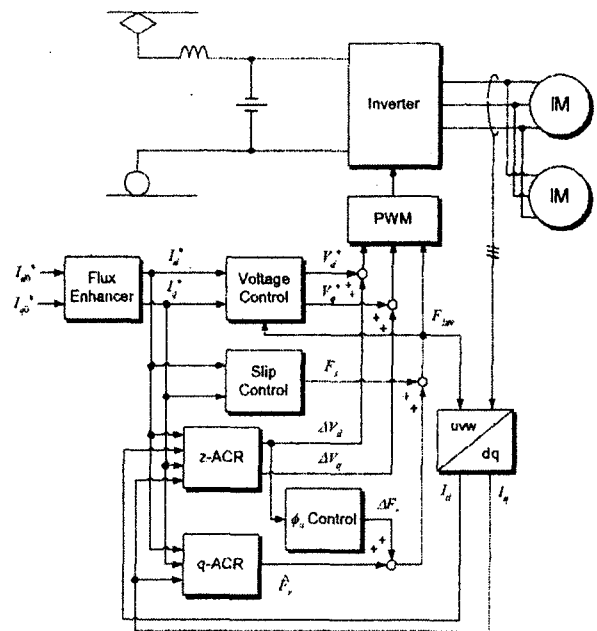

Fig.2 Speed estimation by torque component current feedback

across zero frequency. For conventional vector control system with speed sensor, it is not so difficult thing to control inverter frequency, because actual speed information can be available.

To overcome this zero frequency problem this method uses z- ACR controls both d and q component of motor current Here, d component current used for increasing magnetic flux to avoid zero frequency point.

In this method, the output of current controller on which the estimated current converges to commanded value of current seems to be very skilful idea. But the speed response and stability will depend upon the design of q-ACR.

2.4 Speed estimation by induced voltage calculation ⁽⁴⁾

The inverter output frequency is estimated by induced voltage components E_d and E_q on the rotating coordinates. The principle of this system is shown in Fig. 3.

$$\omega_1 = \frac{E_q}{\phi^*} - \left(K_p + \frac{K_I}{s} \right) E_q \quad (2.5)$$

The first term is reference one. And second term is compensation for system stability.

Here, E_d, E_q are calculated following equations.

$$\left. \begin{aligned} E_d &= \frac{L_2}{M} (v_d^* - (R_1 + \sigma L_1 s) I_d + \omega_1 \sigma L_1 I_q) \\ E_q &= \frac{L_2}{M} (v_q^* - (R_1 + \sigma L_1 s) I_q^* + \omega_1 \sigma L_1 I_d^*) \end{aligned} \right\} \quad (2.6)$$

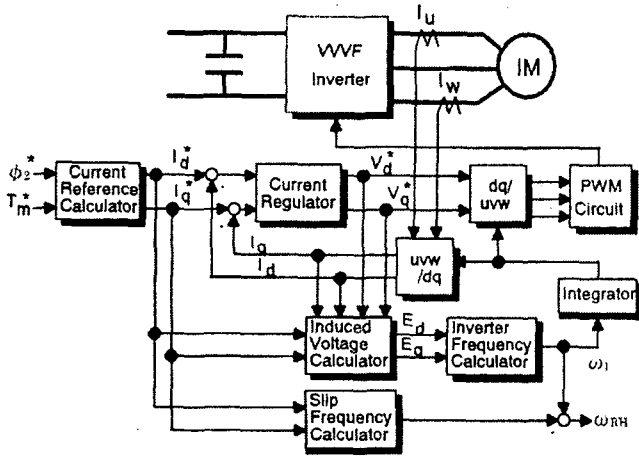

Fig.3 Speed estimation by induced voltage calculation

and rotor speed is obtained by equation (2.7).

$$\omega_{RH} = \omega_1 - \frac{R_2 I_q^*}{L_2 I_d^*} \quad (2.7)$$

The paper uses many space to prove the adhesion control. Sensor-less vector control comes to the age to competes the Anti-slip and anti-skid performance. As for the fine adhesion control, the delay of speed estimation is desirable to as small as possible.

Conventional vector control system for traction drive with speed sensor, the resolution of speed pulse is about 60 pulse/revolution. The new sensor-less vector control system may have advantage as for the delay by this rare pulse in low speed region.

2.4 MRAS based sensor-less vector control ⁽⁵⁾⁽⁶⁾

Sensor-less vector control system based on an adoptive flux observer is studied by many researchers in the world. It is because the control object and control are clear and explicit and the limit of stability by parameter tuning is guaranteed by theoretically.

The state equation of induction motor is expressed by next equation using primary and secondary flux.

$$\frac{d}{dt} \begin{pmatrix} \Psi_1 \\ \Psi_2 \end{pmatrix} = A \begin{pmatrix} \Psi_1 \\ \Psi_2 \end{pmatrix} + B v_1 \quad (2.8)$$

$$i_s = C \begin{pmatrix} \Psi_1 \\ \Psi_2 \end{pmatrix} \quad (2.9)$$

The adjustable system is made by full order observer from above reference model(2.8)and(2.9).

$$\frac{d}{dt} \begin{pmatrix} \hat{\Psi}_1 \\ \hat{\Psi}_2 \end{pmatrix} = \hat{A} \begin{pmatrix} \hat{\Psi}_1 \\ \hat{\Psi}_2 \end{pmatrix} + B v_1 - H(\hat{i}_s - i_s) \quad (2.10)$$

$$\hat{i}_s = C \begin{pmatrix} \hat{\Psi}_1 \\ \hat{\Psi}_2 \end{pmatrix} \quad (2.11)$$

And unknown parameter decide following PI adaptive rule.

$$\hat{\omega} = K_p \left(1 + \frac{1}{K_I s} \right) \frac{(J \hat{\Psi}_2)^T e}{|\hat{\Psi}_2|^2} \quad (2.12)$$

This is the basis of this sensor-less vector control system. Generally, speed estimation system which have PI adjustable rules seems to have the delay due to PI convergence.

3. Some Problems for Sensor-Less Vector Control System

As general industrial drive system, sensor-less vector control system has many practical experience. These problems are also same subject to be solved.

a) characteristics deviation by parameter variation

b) Low speed region, especially zero frequency

Additionally railway vehicle has some inherent problems such as,

c) 1 pulse mode operation

d) parallel motor operation

e) adhesion control

also, problem b) zero frequency operation is serious for railway application in case of starting at uphill.

이 논문은 산업자원부에서 시행한 전력산업 인프라 구축 지원사업으로 수행된 논문입니다.

4. Conclusions

Recent sensor-less paper combined to Anti-slip/skid problem. It is the proof that fine adhesion characteristic is indispensable request for new age railway vehicles.

Sensor-less vector control for railway vehicles is now on start line. Only few trains began to run for service operation. Taking the experience of industrial world into account, efficient and rapid progress is expected.

References

- [1] Miyashita & Y. Ohmori: "Speed Sensorless High Speed Torque and Speed Control of Induction Motor based on Instantaneous Spatial Vector Control" IPEC Tokyo 1990,

pp. 1144-1151.

- [2] T. Hata, H. Hirose, S. Kadowaki, K. Ohishi, N. Iida, M. Takagi, T. Sano, S. Yasukawa, & I. Miyashita: "Test results of the speed sensor-less vector control and disturbance observer based anti-slip control for the electric multiple units, Series 205-5000", 2003 National Convention Record I.E.E. JAPAN, 5-216.
- [3] T. Ogawa, S. Ishida, T. Kojima, & T. Sato: "Test Running with Speed Sensorless Vector Control for Rolling Stock", 2003 National Convention Record I.E.E. JAPAN, 5-213
- [4] K. Yuki, T. Hemmi, T. Hasebe, & I. Yasuoka: "Application of Speed Sensorless Control to railway Traction Field", PCC-Osaka 2002, pp.1033-1038.
- [5] K. Hisatomi, T. Aoki, H. Iida, M. Kono, H. Negoro, H. Yamasaki, & T. Kikuchi: "VVVF Traction Control with Speed Sensorless Control", 2003 National Convention Record I.E.E. JAPAN, 5-215.
- [6] Yoshihiko Kinpara & Masato Koyama: "Speed Sensorless Vector Control Method of Induction Motor Including A Low Speed Region", Transaction I.E.E. Japan, Vol. 120-D, No. 2, 2000, pp. 223-229.