

\* , , ,

# Effect of Pt amount in the Pt/C for cathode catalyst on the performance of PEMFC

\*Y.-H. Cho, Y.-H. Cho, H.-S. Park, Y.-E. Sung  
School of Chemical and Biological Engineering., Seoul National University

Key words : PEMFC , Polarization curve, MEA

1. Pt/C(E-TEK) solution (Dupont), (Vulcan XC) , Ionomer 5% Nafion IPA(Isopropyl alcohol) Ionomer [4].

2.2 MEA MEA Nafion 112 50C 가

2.3 MEA 가 MEA MEA 5 cm 가

[2]. 가 4 mg/cm<sup>2</sup> 10% 가

[3]. 가 I-V 20 wt.% 20, 40, 60, 80 wt.% 가 MEA

70C 1.5/2.0 70C 75C [5].

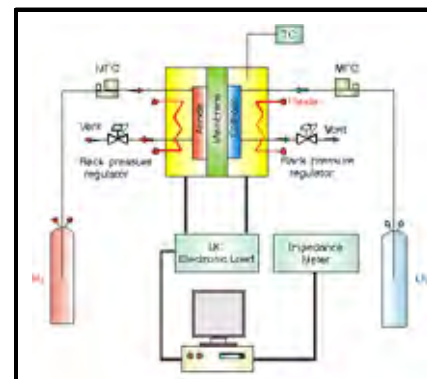

Fig. 1 Schematic diagram of the unit cell performance test station.

