

이단 마이크로 플라즈마 추력기의 개념 설계에 대한 실험적 연구

호 티 탄 트랑* · 신지철*†

Experimental Investigation on Conceptual Design of Dual Stage Micro Plasma Thruster

Ho Thi Thanh Trang* · Jichul Shin*†

ABSTRACT

This work is devoted to an experimental investigation on conceptual design of dual consecutive stage micro plasma thruster (μ PT). Optimization study on the thruster configuration has been performed for various electrode gap distances from 1 mm to 2 mm and the hole diameter from 0.3 mm to 2 mm depending on desired operating conditions and corresponding nozzle design requirement. The operation of μ PT at low pressure from 10^{-1} Torr to 10^{-4} Torr and at various argon flow rates ranging from 5 sccm to 300 sccm has been studied to understand the physic of plasma and the gas dynamics in details. The specific impulse can reach up to 3000-4000 seconds at low power consumptions from 1 to 5 W. Image of exhaust plume from μ PT will be provided and electrical characteristics is also mentioned in this paper.

초 록

이단 마이크로 플라즈마 추력기 (μ PT)의 개념 설계를 위하여 실험적 연구가 수행되었다. 운전 조건 및 노즐의 설계조건에 따른 전극 간격 및 출구 면적의 변화에 대한 추력기의 성능 최적화 연구가 수행되었다. 운전 압력은 10^{-1} Torr에서 10^{-4} Torr의 진공 조건이며 아르곤 가스의 유량은 5 sccm에서 300 sccm에 대하여 추력기의 성능 검증 연구가 이루어 졌다. 소모전력 약 1 watt에서 5 watt의 운전 상태에서 약 3000에서 4000정도의 비추력이 예상된다. 마이크로 플라즈마 추력기에 의해 발생된 토출 제트의 사진 및 전기적 특성에 대한 결과를 포함하였다.

Key Words: Micro Plasma Thruster, Micro hollow Cathode Discharge, Micro Ion Engine, DC Discharge

1. INTRODUCTION

* 울산대학교 기계공학부 항공우주공학전공

† 교신저자, E-mail: jshin@ulsan.ac.kr

The development of many micro spacecraft

concepts has increased the need to investigate the new structure of micro thruster for possible operation that is applied to micro satellites for station keeping and for altitude control. Several types of micro scale electric propulsion have been proposed such as 3 cm electron bombardment Micro-Ion Thruster[1], Micro-hall Thruster[2], Field Emission Electric Propulsion(FEEP)[3], Pulsed plasma thrusters (PPTs)[4], colloid thruster[5], micro plasma thruster using microwave for exciting plasma[6] and Alameda/JPL vacuum Arc Thruster (VAT) that in laboratory development[7].

In our research, we develop the micro hollow cathode discharge configuration as an ion source and employ dual stage operation where the first stage located farther from the exit is used for ionization of fuel gas and the second stage located near the exit is used for accelerating the ions produced in the first stage. In this dual stage configuration, we can achieve a partially selective control of either electro-thermal or electro-static acceleration.

2. EXPERIMENT SETUP

2.1 Experiment setup

Figure 1 shows the schematic drawing of μ PT and experiment setup used for analysing electrical characteristic and providing image of exhaust plume at various operating condition. The common configuration of μ PT consists of three nickel electrode layers separated by mica dielectric material and a circular hole is drilled through the center of the electrode-dielectric layer. The electrodes are made of 100 μ m Nickel (Ni) and are separated from 1 mm to 2 mm. The hole diameter varies from 0.3 mm to 2 mm depending on desired operating

conditions and nozzle design requirement. μ PT setup is placed inside the vacuum chamber that can provide an ambient pressure up to 10^{-6} Torr in a stagnation environment. Due to the gas flow, the back pressure is set at the range from 10^{-1} to 10^{-4} Torr. The ballast resistor is chosen at 100 K . The exhaust plume is imaged by a charge coupled device (CCD) camera with 105 mm focal length lens. A high voltage power supply (SHV300-NP, +15kV, 20mA) provides a high voltage power to μ PT.

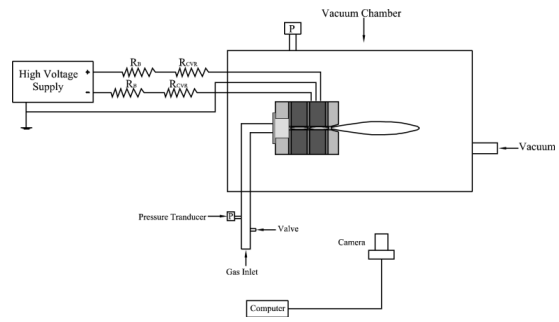

Fig. 1 Schematic of experiment setup of μ PT for imaging and electrical characteristic

3. RESULT

3.1 Electrical characterization

Figure 2 presents the V-I characteristic at low flow rate ranging from 5 sccm to 40 sccm. The back pressure is set at the same value 10^{-1} Torr. The V-I characteristics of the μ PT is obtained by increasing the current from 0.2 mA to 4 mA and monitoring the discharge voltage in the orifice. In this figure the discharge voltage ranges from 1260 V to 3050 V with the current from 0.2 mA to 4 mA. As the discharge voltage was increased, the profile started out having a positive differential resistivity but gradually leveled off to a near zero differential resistivity at current from 2.5 mA. The trend in the differential resistivity

indicated that the discharge gradually transitions into normal glow discharge for increasing current.

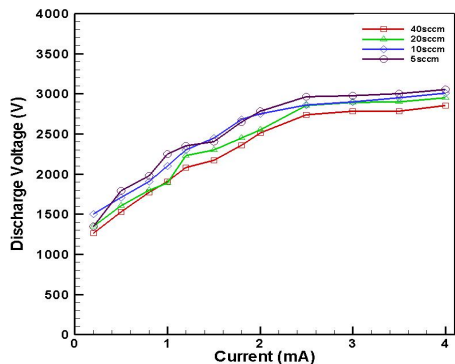

Fig. 2 Electrical characteristic of plasma at various flow rates and back pressure of 10^{-4} Torr.

3.2 Optical Image Analysis

A performance of μ PT is characterized by an optical imaging of the exhausted plume. The length and the angle of exhausted plume related to the velocity and thrust of either electrothermal or electrostatic mode. Fig. 3 shows the exhausted plume from the exit nozzle of μ PT at 1.3×10^{-1} Torr back pressure and flow rate ranging from 80 sccm. The first row is for the operation of the 1st stage only. The 2nd row is for the operation of the 2nd stage only. The last row corresponds to a dual stage operation. Plasma power from the left column to the right ranges increases from 0.52 W to 1.65 W for a single stage operation and from 0.79 W to 2.22 W for a dual stage operation. The plume length drastically increases when the μ PT operates in the second stage and dual stage operation. This infers that the ions generated in the first stage is mostly quenched by the wall surface. As the discharge power increases plume length and jet diameter increases. Interesting phenomenon is that the jet plume in dual stage operation looks very similar with the second stage only operation. This implies that the effectiveness of μ PT is similar for both cases but still

control capability of the μ PT is better in a dual stage operation. Further investigation on a dual stage operation will be presented in the future work.

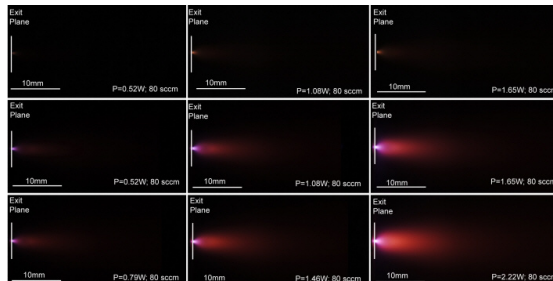

Fig. 3 Exhaust plume of μ PT at various powers and operating modes in the presence of 80 sccm argon gas flow [9].

4. CONCLUSION

Experimental investigation on the operation of microdischarge plasma thruster is presented in this paper. The discharge characteristic at various flow rate and at low back pressure are compared using visual imaging and electrical measurement. The role of dual stage operation is also studied since comparing the exhaust plume at single stage and dual stage operation at the same power. The I-V characteristic shows that the plasma work mainly in the normal glow discharge with zero differential resistivity at high current.

REFERENCES

1. Richchard Wirz, Jame Polk, Colleen Marrese, Juergen Mueller, jesse Escobedo, Patrick Sheehan, "Development and Testing of a 3cm Electron Bombardment Micro-Ion Thruster", IEPC-01-343.
2. Tsuyohito Ito and Mark A.Cappelli,

- "Experimental Characterization of a Micro Hall Thruster", *Journal of Propulsion and Power* Vol23, No.5, September-October 2007.
3. J.Mitterauer. Field Emission Electric propulsion: Emission Site Distribution of Slit Emitters *IEEE Transactions on Plasma science*, Vol Ps-15, No.5, October 1987.
 4. S.Castro and R. Bocanegra, *Appl.Phys.Lett* 88,123105(2006).
 5. Richard Wiz and Juergen Mueller, "Development and Testing of a 3cm Electron Bombardment Micro-Ion Thruster", IEPC-01-343.
 6. Juergen Mueller, John Ziemer, Richard Wirz and Timothy O'Donnell, "Survey of Chemical Propulsion Candidates for Microspacecraft", 2008 Cube Sat-5th Annual Developers Workshop.
 7. D.M. Goebel and I. Katz, "Fundamentals of Electric Propulsion", Wiley& Sons(2008).
 8. M.P. Gomes, B.N. Sismanoglu and J. Amorim, "Characterization of micro hollow cathode Discharges", *brazilian Journal of Physics*, Vol. 39, no.1, March, 2009.
 9. Jichul Shin and Pham Dinh Tuyen, "Exhaust Plume Characteristics of Microhollow Cathod Discharge Plasma Thruster", *IEEE Trans. Plasma Sci.*, in press.