

# Vacuum Suction Force Analysis of Concrete Wall Climbing Device for Dry Cask Storage System

Kyoung Won Yoon, Jin Yoo, Misuk Jang, and Seoung Rae Kim

Nuclear Engineering Service & Solution Co., Ltd., 96, Gajeongbuk-ro, Yuseong-gu, Daejeon, Republic of Korea

kwyoon@ness.re.kr

## 1. Introduction

Sensor transport system(SeTS) is the wall climbing instrument developing to inspect the defects of dry cask storage system(DCSS) wall. Fig. 1 shows the conceptual frame design of SeTS. It is composed of main frame, driving axle connected with electric motor, impeller connected with adsorptive motor, impeller generating negative pressure, lower chamber connected with impeller, seal generating flexibility to contact with the ground, and etc.

Important factors to decide adsorption force of SeTS in these block diagram are the shape and discharge of impeller, a lower chamber shape of impeller, and etc. Therefore, an impeller and a lower chamber of impeller were selected as the calculation area in this analysis. The analysis conditions were selected in consideration of the suction motor specification and the lower chamber of impeller was simulated in the flow range with the highest efficiency of the impeller.

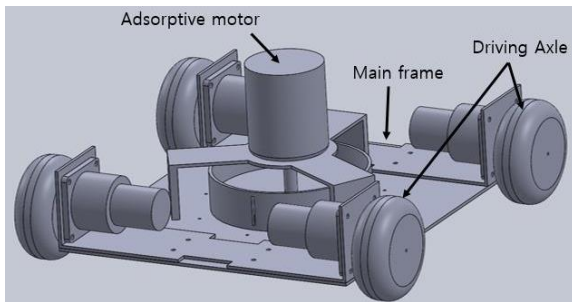

Fig. 1. Shape of SeTS.

## 2. Governing Equation and Calculation Method

We use ANSYS CFX 17.0, which is commercial CFD program based on FVM(Finite Volume Method) in order to get the solution of RANS governing equation.

Continuity equation and momentum equation about 3-dimensional incompressible and normal turbulence flow are as below.

- Continuity equation

$$\frac{\partial U_i}{\partial x_i} = 0 \quad (1)$$

- Momentum equation

$$U_j \frac{\partial U_i}{\partial x_j} + \frac{\partial(\overline{u_i u_j})}{\partial x_j} + \frac{\partial p}{\partial x_i} - \frac{1}{Re} \nabla^2 U_i = c \quad (2)$$

In this analysis, we used  $k-\epsilon$  model among generally 2-equation turbulence models and set the the convergence condition of the solution to the residual  $10^{-4}$ .

## 3. Analysis Condition and Boundary Condition

The analysis conditions were selected in consideration of the fiducial discharge for centrifugal impeller with highest lift compared to discharge. The shape of lower chamber of impeller was assumed that a fluid enters through the lower intake of 5mm and exits through outlet of impeller. In the future, we plan to derive the optimized shape through experiments. The fluid passing through centrifuge impeller was assumed to be a standard air.

Details of analysis and boundary conditions are given in Table 1 and Table 2.

Table 1. Analysis conditions

Input Item	Value
Mass flow rate [kg/s]	0.0198
Rotational speed [RPM]	7600
Outlet diameter of Impeller [mm]	130
Inlet diameter of Impeller [mm]	20
Number of blade [EA]	10
Gap between the floor and chamber [mm]	5

Table 2. Boundary conditions

Working fluid	Air
Inle	Total pressure
Outlet	Mass flow rate
Turbulent closure	$k-\epsilon$ model
Interface area	Frozen-rotor
Wall	No-slip

#### 4. Result of Analysis

Fig. 2 shows the inflow velocity vector of an impeller. As shown in the figure, pressure drop occurs at the inlet of impeller and the impeller rotation speed increases. And the flow field inside the impeller generates a complex recirculation flow and vortex due to the rapid rotation of the impeller.

Fig. 3 shows the pressure distribution in the axial center section to confirm the flow characteristics of the impeller. As shown in the figure, the lower and upper chamber are constant at atmospheric pressure, while the pressure is gradually lowered toward the impeller exit portion.

The force applied to the lower part of the impeller by using the pressure and area derived from this analysis result is about 7.8kgf. Therefore, SeTS can deliver mounting up to 3.8kg of sensors and accessories excluding device to inspect the inner surface of dry storage cask wall.

#### 5. Conclusion

In this paper, we have examined the capacity of SeTS equipped with some sensors and accessories and climbing the walls using CFD code.

As a result, the impeller with 10 blades, 7,600 rpm speed and 0.0198kg/s flow rate was evaluated to be able to mount up to 3.8kg excluding device when the gap between the wall surface and chamber is 5mm. If sensors and accessories are determined in the future, the final design will be carried out through additional analysis that reflects these conditions. And the final SeTS will also be designed to operate under high temperature and high radiation conditions.

#### ACKNOWLEDGEMENTS

This work was supported by the Korea Institute of Energy Technology Evaluation and Planning(KETEP) and the Ministry of Trade, Industry & Energy(MOTIE) of the Republic of Korea(No.201715201017800).

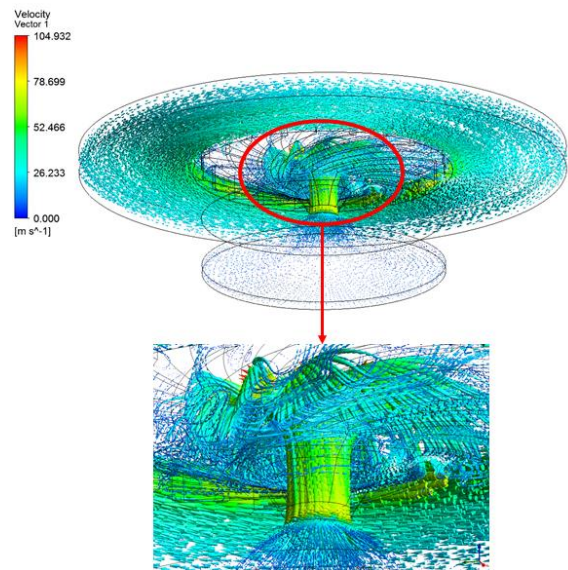

Fig. 2. Distribution of Pressure in Chamber of SeTS.

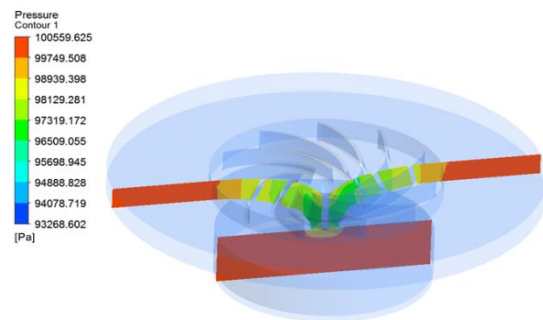

Fig. 3. Distribution of Pressure in the Chamber of SeTS.

#### 6. References

- [1] Dong chul Choi, A study on the tip clearance effect of the suction fan for a NDT robot, Master degree thesis, May 2014, Hanyang University.
- [2] Choon-Man Jang, Performance Analysis for Turbo Blower According to Inlet-Vane Angles, December 2010.
- [3] Jeong, Seon Yong, Optimum design and performance of marine sea water pump with impeller using CFRP. Journal of the Korea Academia-Industrial cooperation Society, November 30, 2015.
- [4] Myung Seok, Kim, A Study on the Design and performance Analysis of Horizontal Single Suction Centrifugal Pump by CFD, Master degree thesis, February 2006, Korea Maritime and Ocean University.