

Incremental Cross Sections for CANDU-PHWR Core Analysis

Hang Bok Choi and Seong Yun Kim
Korea Advanced Energy Research Institute

Chang Hyun Chung
Seoul National University
(Received February 18, 1985)

CANDU-PHWR의 증분단면적 계산방법에 대한 연구

최 항 복 · 김 성 년
한국에너지연구소

정 창 현
서울대학교
(1985. 2. 18 접수)

Abstract

A number of reactivity devices are distributed in a CANDU-PHWR core to control the power distribution and excess reactivity. The effects of these devices are represented by incremental cross sections in core analysis. The incremental cross sections are generated by the SUPERCELL code using the two-group constant set calculated by the lattice code, WIMS. The incremental cross sections are then assessed for adjusters and zone controller by core simulation. Reactivity worth and channel powers are compared to the reference values. The deviation of reactivity worth and the maximum channel power are less than 0.97% and 0.6%, respectively, for the initial and equilibrium core.

요 약

가압중수로인 CANDU의 노심에는 많은 반응도 조절장치들이 분포되어 있어 출력분포와 잉여반응도를 조절하며, 이러한 장치들의 효과는 노심해석에서 증분격자상수로 나타낸다. 격자코드인 WIMS를 사용하여 2군 균정수를 계산하고 이를 이용하여 SUPERCELL코드로 증분 격자상수를 생산하였다. 증분격자상수는 조정봉과 지역조절장치에 대해 노심해석을 통해 평가하였으며 반응도가와 채널출력을 참고 자료와 비교하였다. 반응도가와 최대채널출력 오차가 참고값에 대해 각각 0.97%와 0.6% 범위 내에서 나타났다.

I. Introduction

Reactivity devices of CANDU-PHWR are located vertically through the midst of fuel chan-

nels which are horizontally arranged in the core. Hence, these devices cannot be easily represented for CANDU core analysis due to geometrical complexity. Therefore, the properties of a device are usually smeared over a certain region along

the entire length of the device, which results in addition of reaction cross sections to that region.

The reactivity control devices of a CANDU-PHWR consist of adjuster rods, zone controller units, mechanical control absorbers and shutoff rods. Of these devices, mechanical control absorbers and shutoff rods are fully withdrawn when a reactor is normally operating at full power. Adjuster rods of stainless steel are, however, fully inserted into the core during normal operation. Zone controller units regulate the reactor power of each zone by varying the amount of light water in the corresponding compartment. Incremental cross sections are thus considered for zone controller units and adjusters.

There are two methods available to model reactivity devices. One method is that fuel and reactivity devices are treated as line sources and line sinks in the reactor simulation model. This method^(1,2) has been introduced since 1956, but has not been used in power reactor simulations because of long computing time. The other method⁽³⁾ is that reactivity devices are presented in the reactor model as regions with modified neutron cross sections. This method is preferred, since it is simple to apply and requires relatively short computing time. In this method, neutronic interaction between fuel and reactivity device is precalculated and its effect is implicit in the cross sections that are assigned to the regions representing the reactivity devices.

The SUPERCELL program is used for the precalculation and the method used for the generation of incremental cross section is developed for the CANDU-PHWR lattice in this work. And the method is developed to be applicable when the design parameters such as fuel enrichment are changed.

II. Numerical Calculations

II. 1 Lattice Calculations

Considered in a lattice calculation is a unit cell consisting of single fuel channel and appropriate amount of moderator. The lattice cell of CANDU-PHWR is presented in Fig. 1. The cell is modified to have cylindrical configuration in order to use the WIMS code⁽⁴⁾ as shown in Fig. 2.

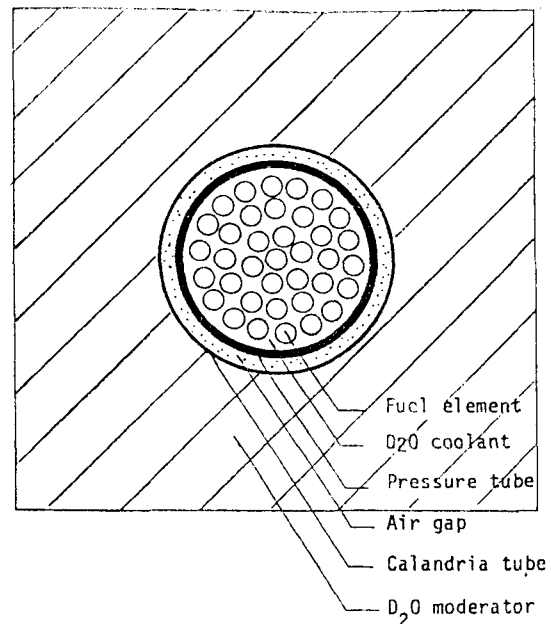
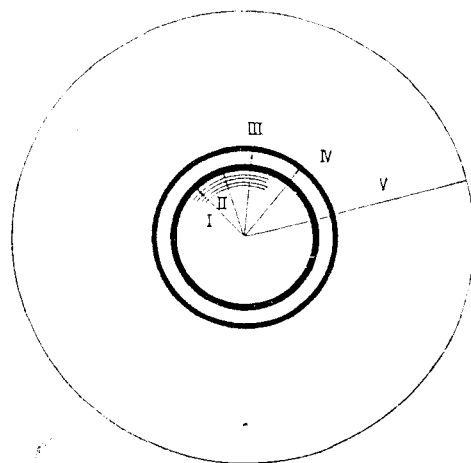

Fig. 1. Lattice Cell for 37 Elements Fuel



I. Fuel, Clad, Coolant annulus II. Pressure tube
 III. Air gap IV. Calandria tube
 V. Moderator

Fig. 2. Lattice Cell Model in WIMS

II. 1.1. WIMS Model

Although it is possible in practice to perform transport calculations in all WIMS 69 library⁽⁵⁾ groups, it is practical for energy groups not to be elaborated since few group calculations can do with little error in a well-thermalized reactor such as a CANDU-PHWR.⁽⁶⁾ Ten broad energy groups are used to generate two group constants, and Table 1 shows energy group boundaries. Two-group constants are calculated from ten-group constants.

Neutron thermalization is represented by the single cross section, Σ_R , to account for the effective thermalization of fast neutrons. Neutron production is also represented by the single notation, $\nu\Sigma_f$, to conserve the total neutron production. Two-group constants spatially weighted are calculated from energy collapsed group constants by flux-volume weighting. The one dimensional cell cross section is designated by Σ_{1D} .

In the WIMS model, the cell is divided into three regions such as fuel channel, annulus tube and moderator for the lattice which does not

Table 1. Energy Group Boundaries
Broad Group Boundaries

Group	Energy(eV)
1	$1.0 \times 10^7 \sim 1.1 \times 10^5$
2	$1.1 \times 10^5 \sim 9118.0$
3	$9118.0 \sim 148.728$
4	$148.728 \sim 9.877$
5	$6.877 \sim 4.00$
6	$4.00 \sim 1.15$
7	$1.15 \sim 0.625$
8	$0.625 \sim 0.250$
9	$0.250 \sim 0.030$
10	$0.030 \sim 0.0$

Two Group Boundaries	
Group	Energy(eV)
1	$1.0 \times 10^7 \sim 0.625$
2	$0.625 \sim 0.0$

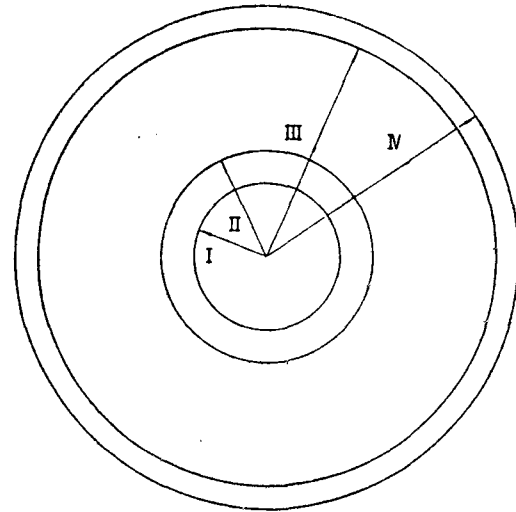

I. Fuel region II. Annulus tube
III. Moderator region IV. Reactivity device

Fig. 3. WIMS Model for Reactivity Device

include reactivity device. If the cross sections of cell materials with reactivity device are required, the equivalent volume of the device is located at the boundary of the lattice cell as shown in Fig.3.

II. 1.2. Time-averaged Model

For the equilibrium core, the core contains fuels ranging in irradiation from zero to some terminal irradiation. The time-averaged parameters at terminal irradiation represent the average over all irradiation intervals. The terminal irradiation used in this model is 6500 MWd/tU.

The time-averaged cross section is represented as follows:

$$\Sigma = \frac{\sum_{j=1}^n \Sigma(\Delta w_j) \Delta w_j}{\sum_{j=1}^n \Delta w_j}$$

where j denotes the time-interval mesh, Δw_j is the amount of irradiation and $\Sigma(\Delta w_j)$ represents the interval-averaged cross section.

The H -factor is defined as the fission power over the average thermal flux in the cell,

$$H = \frac{\sum_i^{\text{fuel}} \epsilon N^i \sigma_f^i \phi_{1/2}^i v^i}{\phi_{2, \text{cell}}}$$

where ϵ is the average energy released per fission. This factor is used to calculate the channel power by multiplying average thermal flux of the cell which contains the fuel channel.

II. 2 SUPERCELL Calculations

II. 2.1 Modelling

The properties of a given device are smeared over a fairly large region along the entire length of the device. The choice of size of this region is arbitrary. However, one lattice pitch by one bundle length⁶⁾ is typically taken for this study. The SUPERCELL code is used for the supercell calculations. The supercell model is taken as 1/8 of the the three dimensional lattice because of symmetrical geometry as shown in Fig. 4. Model (A) is a cell without a device, model(B) is with a rod-in-tube adjuster, and the last model(C) is with a zone controller.

A rectangular geometry is simply used in the supercell since the SUPERCELL code is a diff-

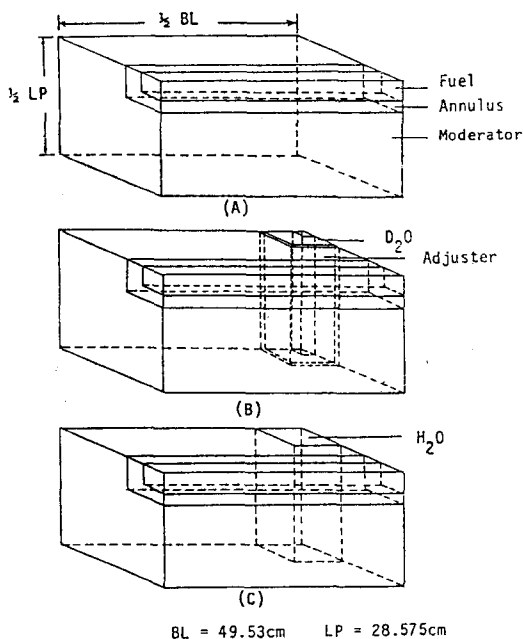

Fig. 4. Supercell Model (A), (B), (C)

usion code which has rectangular meshes, and two kinds of modelling are tested. In the first model, the volume of each region is kept unchanged when converting from the cylindrical geometry to the rectangular one. In the second model, the surface area of the fuel region is kept unchanged. Hence, the cross sections of the fuel region are increased by a factor of $4/\pi$ and the cross sections of the annulus region are decreased by a factor of $(Rc^2 - a^2)/(Rc^2 - \frac{\pi a^2}{4})$, where Rc is the outer radius of the calandria tube and a is the outer radius of the fuel channel.

The results of these two models are compared with those of the WIMS in Table 2 for the initial core and the second model is adopted for supercell calculations.

Table 2. Flux Distributions in WIMS and SUPERCELL

Average regional flux	WIMS	SUPERCELL			
		Equivalent volume		Equivalent surface area	
			Deviation (%)		Deviation (%)
Thermal flux					
Fuel	1.0	1.0	0.0	1.0	0.0
Annulus	1.37220	1.22439	10.8	1.24219	9.5
Moderator	1.82640	1.61609	11.5	1.62981	10.2
Fast flux					
Fuel	1.24358	1.18778	4.5	1.18933	4.4
Annulus	0.96075	0.99499	3.6	0.98125	2.1
Moderator	0.64935	0.70878	9.2	0.68742	5.9

$$\text{Deviation} = \left| \frac{\text{WIMS} - \text{SUPERCELL}}{\text{WIMS}} \times 100 \right| (\%)$$

II. 2.2. Incremental Cross Sections

The cross sections for supercells which contain reactivity devices are obtained by incrementing⁷⁾ the cross sections, Σ_{1D} , calculated by the lattice code WIMS,

$$\Sigma' = \Sigma_{1D} \frac{\Sigma'_{3D}}{\Sigma_{3D}}$$

where Σ'_{3D} and Σ_{3D} are cross sections of a supercell with and without a reactivity device,

respectively. Σ_{3D} differs slightly from Σ_{1D} because:

- (1) a rectangular geometry is used to obtain Σ_{3D} whereas a radial geometry is used for Σ_{1D} ,
- (2) two codes, SUPERCELL and WIMS, are basically different in the solution procedures.

The incremental cross section and incremental H-factor are represented as following:

$$\Delta\Sigma = \Sigma_{1D} \left(\frac{\Sigma'_{3D}}{\Sigma_{3D}} - 1 \right)$$

$$\Delta H \cong H_{1D} \left(\frac{\left(\frac{\sum_i^{fuel} \nu \Sigma_f \phi_2^i V^i}{\bar{\phi}_{2,cell}} \right) 3D' - 1}{\left(\frac{\sum_i^{fuel} \nu \Sigma_f \phi_2^i V^i}{\bar{\phi}_{2,cell}} \right) 3D} \right)$$

where subscript $3D'$ and $3D$ are the values of the supercell with and without a reactivity

device.

Incremental cross sections are thus calculated and tabulated in Tables 3 and 4 for the initial and equilibrium core. The physical characteristics of adjusters and zone controller are in reference (6).

III. Core Simulations

The incremental cross sections calculated by the SUPERCELL are assessed for the initial and equilibrium core through core simulations using the reference incremental cross sections⁸⁾ which were derived by different methods^{7,9)} and verified by experiments.¹⁰⁾ In core simulations, the cell averaged cross sections are obtained from the POWDERPUR-V^{11,12)} code and the CHEBY code¹³⁾ is used for the core simulations. Table 5

Table 3. Incremental Cross Sections for Initial Core*

Adjuster type	$\Delta\Sigma_{tr_1}$	$\Delta\Sigma_{tr_2}$	$\Delta\Sigma_{a_1}$	$\Delta\Sigma_{a_2}$	$\Delta\nu\Sigma_f$	$\Delta\Sigma_R$	ΔH
1	-.11048 E-2	-.35545 E-2	.72751 E-4	.50605 E-3	.76404 E-4	.71529 E-4	.38504 E-2
2	-.12388 E-2	-.36776 E-2	.64836 E-4	.44945 E-3	.64068 E-4	.62088 E-4	.32194 E-2
3	-.88802 E-4	-.32646 E-2	.11462 E-3	.82096 E-3	.16096 E-3	.12876 E-3	.80878 E-2
4	-.88802 E-4	-.32646 E-2	.11462 E-3	.82096 E-3	.16096 E-3	.12876 E-3	.80878 E-2
5	-.14013 E-3	-.33359 E-2	.11224 E-3	.79632 E-3	.15656 E-3	.12609 E-3	.78613 E-2
6	-.15032 E-2	-.38170 E-2	.49095 E-4	.35073 E-3	.39713 E-4	.42218 E-4	.19973 E-2
7	-.14349 E-2	-.37293 E-2	.55452 E-4	.38264 E-3	.45563 E-4	.49290 E-4	.22962 E-2
8	.48502 E-4	.97461 E-4	.12349 E-4	.13542 E-4	.36206 E-4	.14196 E-4	.18205 E-2
Zone controller unit	.21853 E-2	.14544	.16578 E-5	.12148 E-2	.82633 E-4	.12994 E-2	.41452 E-2

* 1.59ppm of natural boron in moderator

Table 4. Incremental Cross Sections for Equilibrium Core†

Adjuster type	$\Delta\Sigma_{tr_1}$	$\Delta\Sigma_{tr_2}$	$\Delta\Sigma_{a_1}$	$\Delta\Sigma_{a_2}$	$\Delta\nu\Sigma_f$	$\Delta\Sigma_R$	ΔH
1	-.11144 E-2	-.26533 E-2	.50777 E-4	.55672 E-3	.94615 E-4	-.19161 E-4	.45404 E-2
2	-.12457 E-2	-.28842 E-2	.43075 E-4	.49822 E-3	.86388 E-4	-.12562 E-4	.41414 E-2
3	-.12289 E-3	-.15012 E-2	.92812 E-4	.88409 E-3	.14583 E-3	-.55345 E-4	.69975 E-2
4	-.12289 E-3	-.15012 E-2	.92812 E-4	.88409 E-3	.14583 E-3	-.55345 E-4	.69975 E-2
5	-.17198 E-3	-.16095 E-2	.90486 E-4	.85886 E-3	.14281 E-3	-.53662 E-4	.68420 E-2
6	-.15027 E-2	-.32384 E-2	.27592 E-4	.39616 E-3	.70279 E-4	-.16681 E-5	.33533 E-2
7	-.14358 E-2	-.31000 E-2	.33552 E-4	.42872 E-3	.74004 E-4	-.37400 E-5	.35395 E-2
8	.64339 E-4	.44610 E-4	.10250 E-4	.46805 E-4	.19985 E-4	.12777 E-4	.94222 E-3
Zone controller unit	.72543 E-2	.14039	.26228 E-3	.12553 E-2	.87593 E-4	.24587 E-2	.41882 E-2

† Burnup=6,500MWd/tU, Boron concentration=0.0ppm

Table 5. Simulation Conditions

	Initial Core	Equilibrium Core
Depleted fuels	Loaded	Unloaded
Boron in D ₂ O moderator	1.59ppm	0.0ppm
Adjusters	fully inserted	fully inserted
Zone controller level	44.3%	63.8%

Table 6. Reactivity Worth Comparisons

		Reference*	SUPERCELL	Deviation(%)
Initial core	Adjusters	13.24039	13.32189	0.62
	Zone controller	7.36985	7.29967	0.95
Equilibrium core	Adjusters	15.81632	15.87017	0.34
	Zone controller	7.34340	7.41478	0.97

* Values are obtained by core simulation using the reference incremental cross sections

Table 7. Maximum Power Deviations

	Reactivity devices*	Max. channel power deviation(%)	Max. bundle power deviation(%)
Initial core	Adjusters	0.6	1.0
	Zone controller	0.1	0.5
Equilibrium core	Adjusters	0.6	1.2
	Zone controller	0.3	1.3

* Devices for which incremental cross sections calculated by the SUPERCELL are used

	01	02	03	04	05	06	07	08	09	10	11
A									0.1	0.1	0.1
B					0.0	0.0	0.1	0.1	0.1	0.1	0.1
C				0.0	0.0	0.0	0.0	0.1	0.1	0.1	0.1
D			0.0	0.0	0.0	0.0	0.0	0.1	0.1	0.1	0.2
E		0.0	0.0	-0.1	-0.1	-0.1	-0.1	0.0	0.1	0.2	0.2
F		0.0	0.0	-0.1	-0.1	-0.3	-0.3	0.1	0.2	0.2	0.2
G	0.0	0.0	0.0	-0.2	-0.3	-0.4	-0.3	0.1	0.3	0.2	0.2
H	0.0	0.0	0.0	-0.2	-0.3	-0.4	-0.3	0.1	0.3	0.3	0.3
J	0.1	0.1	0.0	0.0	-0.2	-0.3	-0.3	-0.2	0.1	0.4	0.5
K	0.1	0.1	0.1	0.1	0.0	-0.2	-0.3	-0.3	0.1	0.4	0.5
L	0.1	0.1	0.1	0.1	0.0	-0.1	-0.3	-0.2	0.1	0.4	0.6
M	0.1	0.1	0.1	0.1	0.0	-0.1	-0.3	-0.3	0.1	0.4	0.6
N	0.1	0.1	0.1	0.0	0.0	-0.2	-0.3	-0.2	0.1	0.4	0.5
O	0.1	0.1	0.0	0.0	-0.2	-0.3	-0.3	-0.3	0.1	0.3	0.4
P	0.0	0.0	0.0	-0.2	-0.3	-0.4	-0.3	0.1	0.3	0.3	0.3
Q	0.0	0.0	0.0	-0.3	-0.3	-0.4	-0.3	0.1	0.2	0.2	0.2
R		0.0	0.0	-0.1	-0.2	-0.3	-0.3	0.1	0.2	0.1	0.1
S		0.0	0.0	-0.1	-0.1	-0.1	-0.1	0.0	0.1	0.1	0.1
T			0.0	0.0	-0.1	0.0	0.0	0.1	0.1	0.1	0.1
U				0.0	0.0	0.0	0.0	0.1	0.1	0.1	0.1
V					0.0	0.0	0.1	0.1	0.1	0.1	0.1
W									0.1	0.1	0.1

Values in percent (%)

Fig. 5. Channel Power Deviations for Adjusters-Initial Core

	01	02	03	04	05	06	07	08	09	10	11
A									0.0	0.0	0.0
B						0.0	0.0	0.0	0.0	0.0	0.0
C					0.0	0.0	0.0	0.0	0.0	0.0	0.0
D				0.0	0.0	0.0	0.0	0.0	0.0	0.0	-0.1
E			0.0	0.0	0.0	0.0	0.0	0.0	0.0	0.0	-0.1
F			0.0	0.0	0.0	0.0	0.0	0.0	0.0	0.0	-0.1
G		0.0	0.0	0.0	-0.1	-0.1	0.0	0.0	0.0	0.0	0.0
H		0.0	0.0	0.0	-0.1	-0.1	0.0	0.0	0.0	0.0	0.0
J	0.0	0.0	0.0	0.0	-0.1	-0.1	0.0	0.0	0.0	0.0	0.0
K	0.0	0.0	0.0	0.0	-0.1	-0.1	0.0	0.0	0.0	0.0	0.0
L	0.0	0.0	0.0	0.0	0.0	0.0	0.0	0.0	0.0	0.0	0.0
M	0.0	0.0	0.0	0.0	0.0	0.0	0.0	0.0	0.0	0.0	0.0
N	0.0	0.0	0.0	0.0	0.0	0.0	0.0	0.0	0.0	0.0	0.0
O	0.0	0.0	0.0	0.0	0.0	0.0	-0.0	0.0	0.0	0.0	0.0
P	0.0	0.0	0.0	0.0	0.0	0.0	0.0	0.0	0.0	0.0	0.0
Q		0.0	0.0	0.0	-0.1	-0.1	0.0	0.0	0.0	0.0	0.0
R			0.0	0.0	-0.1	-0.1	0.0	0.0	0.0	0.0	0.0
S				0.0	0.0	-0.1	-0.1	0.0	0.0	0.0	-0.1
T					0.0	0.0	0.0	0.0	0.0	0.0	-0.1
U						0.0	0.0	0.0	0.0	0.0	-0.1
V							0.0	0.0	0.0	0.0	0.0
W									0.0	0.0	0.0

Values in percent (%)

Fig. 6. Channel Power Deviations for Zone Controller-Initial Core

shows assumptions used in core simulations.

From the simulation, reactivity worths are calculated and compared in Table 6. Fig. 5 and 6 show the initial core channel power deviations from the values which were obtained using the reference incremental cross sections,⁸⁾ when incremental cross sections calculated by the SUPERCELL are used for the reactivity device. The channel power deviations for the equilibrium core are slightly higher than those of the initial core. The maximum channel and bundle power deviations from the reference values are shown in Table 7.

IV. Summary and Conclusions

- (1) A method has been developed to calculate incremental cross sections for regions in CANDU-PHWR core that contain reactivity devices.
- (2) The method uses the WIMS code to calculate material cross sections in a supercell and the SUPERCELL code to calculate the incremental cross sections of a supercell using the cross sections obtained from the WIMS.

(3) Depending on the size of a supercell model, the computing time for supercell cross sections varies typically 100 sec to 400 sec on a CYBER 174-16 while the integral transport method⁹⁾ takes 950 sec to 1050 sec.

(4) Deviations of reactivity worth and channel power distributions are within 0.9% and 0.6%, respectively. A conclusion can be drawn from the results that the method is very useful for a CANDU-PHWR analysis with reactivity devices.

(5) The present method has, however, some limitations because of various assumptions taken for the modelling and approximations. It is thus recommended to develop a practical computer code by use of an integral transport method or a transport-corrected diffusion method.

References

1. J.D. Stewart, et al., "A G-20 Program for Calculation of Finite Lattices by Microscopic Discrete Theory," AECL-2547, 1966.
2. S.M. Feinberg, "Heterogeneous Methods for Calculating Reactors: Survey of Results and Comparison with Experiments," Proceedings of the International Conference on the Peaceful Uses of Atomic Energy of Geneva, vol. 5 p.484, 1956.
3. W.J. Eich et al., "Calculation of Reactivity Worth of Rod-Cluster Control Elements and Correlation of Theory with Experiment," *Nucl. Sci. Eng.*, **24**, 272, 1966.
4. J.R. Askew et al., "A General Description of the Lattice Code WIMS," JBNES, 1966.
5. C.J. Taubman, "The WIMS 69 group Library Tape 166259," AEEW-M 1324, 1975.
6. "CANDU-600 Generating Station Physics Design Manual," DM-59-01100, 1980.
7. A.R. Dauster and D.B. Buss, "MULTICELL-A 3-D Program for the Simulation of Reactivity Devices in CANDU reactors," AECL-7544, 1983.
8. D. Jenkins, et al., "Fuel Management in CANDU-600," TDAI-158, 1980.
9. H.C. Chow and M.H.M. Roshd, "SHETAN-A Three Dimensional Integral Transport Code for Reactor Analysis," AECL-6878, 1980.
10. R.T. Jones, "Adjuster Rod Experiments in ZED-2," AECL-5853, 1977.
11. E.S.Y. Tin and P.C. Loken, "POWDERPUFS-V Physics Manual," TDAI-31, 1979.
12. S.Y. Kim et al., "Some Studies on Physics Parameters of Wolsung Unit No.1," *J. of KNS*, Vol. 12, 2, 1980.
13. B. Rouben et al., "CHEBXEMAX User's Manual," TDAI-187, 1980.