

무손실 수동스너버를 갖는 고역율 부스트 정류기

김 만 고*

High-Power-Factor Boost Rectifier with a Passive Lossless Snubber

M. G. Kim

Key words : Boost converter(부스트 컨버터), Power factor correction(역율 개선), Energy recovery snubber(에너지 재생 스너버)

Abstract

A passive energy recovery snubber for high-power-factor boost rectifier, in which the main switch is implemented with a MOSFET, is described in terms of the equivalent circuits that are operational during turn-on and turn-off sequences. These equivalent circuits are analyzed so that the overshoot voltage across the main switch, the snubber current, and the turn-off transition time can be predicted analytically. From these results, the normalized overshoot voltage is reduced to 1 as $\omega_2 T_{on}$ varies from zero to $\pi/2$, and then it is fixed at 1 for $\omega_2 T_{on} > \pi/2$. The peak snubber inductor current is directly proportional to the input current. The turn-off transition time $\omega_1 t_{off}$ varies from 0 to 2.57, depending on $\omega_2 T_{on}$.

The main switch combined with proposed snubber can be turned on with zero current and turned off at limited voltage stress. The high-power-factor boost rectifier with proposed snubber is implemented, and the experimental results are presented to confirm the validity of proposed snubber.

I. Introduction

Snubbers are required to limit di/dt and dv/dt in the power semiconductor device, keep the

device within its safe operating areas, and to reduce the switching power losses in the device. Conventional snubbers, which discharge via resistors, are simple to design and use, but the

* 부경대학교 제어계측공학과(원고접수일 : 98년 4월)

energy dissipated in the resistors is proportional to the switching frequency. Therefore, resistive snubbers are not practical at the high switching frequencies encountered in the modern power electronics system. In high frequency applications, it is necessary to use an energy recovery snubber to keep losses to a minimum, by regenerating the energy trapped in the snubber circuit back into the DC rail.

For the pulse - width - modulated(PWM) boost converter, several methods have been described to recover the trapped energy in the snubber circuit [1] - [4]. An active auxiliary switch is used in [1] - [2] to regenerate the trapped energy to DC output. The auxiliary switch also provides a soft switching for the main semiconductor switch. But, an additional control circuit is needed to drive the auxiliary switch. In [3], the trapped energy is transferred into the load through a DC/DC converter. This method could be expensive due to the energy recovery converter, as well as being more complex than other methods. A transformer may also be used as a passive element in an energy recovery circuit[4]. The turn - on snubber inductor is replaced with a transformer, so that the energy in the inductor is recovered into the output via the secondary winding of the transformer. The control circuit of this method is the same as that of the basic boost converter. However, the transformer for this snubber may be difficult to construct and the voltage on the main switching device may exceed the output voltage.

In this paper, a lossless snubber using a few passive components [5] is elaborately described, and operational equations are derived. The high - power - factor boost rectifier in combination with this snubber is implemented, and the experimental results are provided.

II. Energy Recovery Snubber for Boost Converter

In a boost converter, the output voltage is greater than the input voltage. A basic boost converter is shown in Fig. 1. When Q is closed, the inductor current rises and energy is stored in the inductor L. The input current flows through inductor L and transistor Q. If the switch Q is opened, the energy stored in the inductor is transferred to load through diode D, and the inductor current falls. The input current would now flow through L, Co, load, and diode D. Now, if the switch Q is turned on again, the diode D would behave as a short circuit. The rate of rise of the forward current of Q and the rate of fall of the forward current of D would be very high, tending to be infinity. The peak reverse current could be very high,

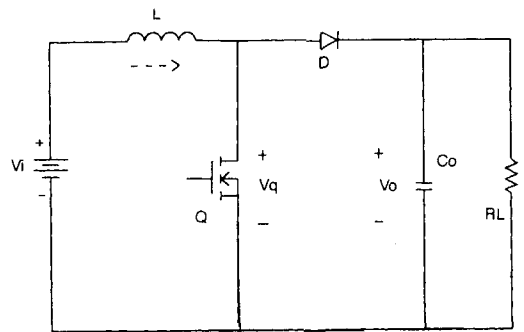

Fig. 1. Basic boost converter circuit.

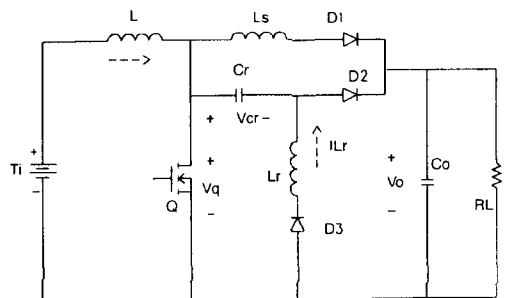

Fig. 2. Proposed boost converter circuit.

and the power semiconductor devices may be damaged. This problem is normally overcome by connecting a di/dt limiting inductor, L_s , between Q and D. Unfortunately the di/dt limiting inductor is equally effective when the transistor is turned off and turns the diode D on again. A turn-off snubber is therefore needed to limit the rise of voltage across Q. If the switch Q is constructed with power MOSFETs, the switching speed of these devices is such that often no turn-off snubber is needed. Instead, a voltage limiter is used to absorb the rate of rise of the voltage across the MOSFETs [6].

Fig. 2 shows the circuit diagram of proposed energy recovery snubber circuit for boost converter. Since the circuit uses a MOSFET for main switch, the purpose of turn-off snubber consisting of Cr and D2 is to clamp the voltage across this MOSFET. When Q is turned on, the rate of rise of the forward current of Q is limited by the current limiting inductor L_s . When Q is turned off, the flow of current to the load is gradually changed from D2 to D1, and the snubber capacitor Cr is charged to its positive peak value. If Q is turned on again, the trapped energy in Cr is discharged through D3 and L_r , and the polarity of the capacitor energy is reversed. During the next turn-off transition period of Q, the snubber energy is recovered into the load through Cr - D2 path or D3 - L_r - D2 path.

III. Operation Analysis of Boost Converter with Proposed Snubber

To simplify the analysis, the following assumptions are made :

- 1) input filter inductance is large so that I_L is constant,
- 2) output filter capacitance is large so that V_o is constant,

3) all semiconductor devices are ideal.

Furthermore, the following symbols are also defined :

$$w_1 = 1/\sqrt{L_s C_r}, Z_1 = \sqrt{L_s/C_r},$$

$$T_{on} = \text{turn-on period of Q,}$$

$$w_2 = 1/\sqrt{L_r C_r}, Z_2 = \sqrt{L_r/C_r}.$$

Depending on the operating conditions, the proposed snubber circuit can be in Region - 1 operation in which the variation of $w_2 T_{on}$ is in the range from π to infinity or in Region - 2 operation in which the variation of $w_2 T_{on}$ is in the range between 0 and π . The theoretical wave forms of Fig. 2 for Region 1 and 2 are shown in Fig. 3 and Fig 4, respectively. The converter goes

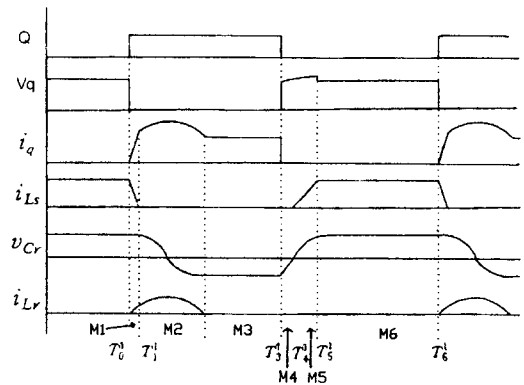

Fig. 3. Typical Region-1 waveforms.

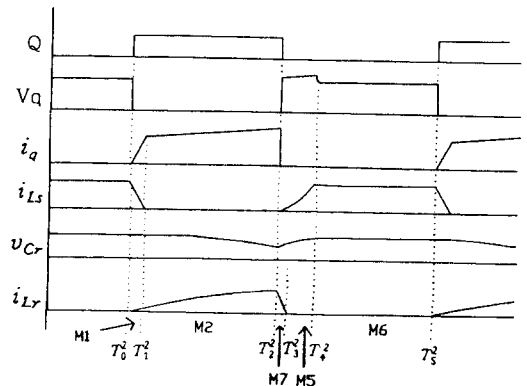

Fig. 4. Typical Region-2 waveforms.

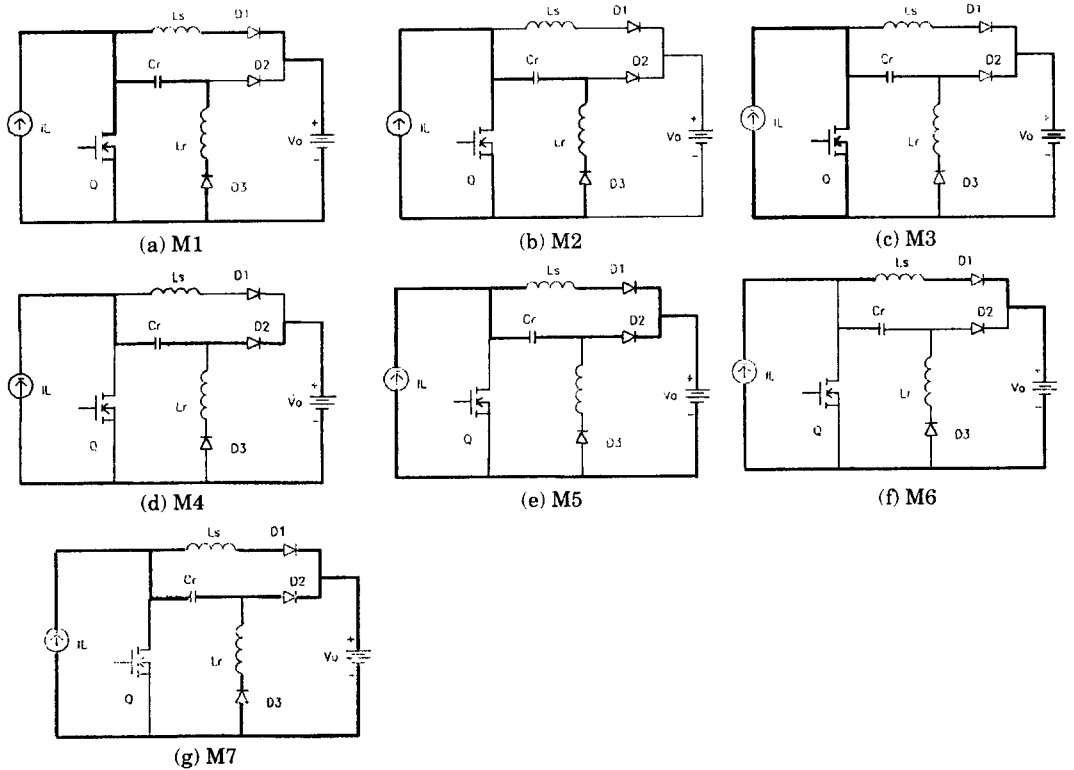

Fig. 5. Equivalent circuits for different topological modes.

through different topological modes(M1, M2, ..., M7) in a steady-state cycle. The corresponding equivalent circuits of the converter in each of the topological modes are given in Fig. 5. Since the voltage across output capacitor and the current on input inductor are both constant, they are replaced by the dc sources V_o and I_L , respectively.

A. Region - 1 Operation ($\omega_2 T_{on} > \pi$)

The sequence of topological modes in Region - 1 operation are M1, M2, M3, M4, M5, and M6. This operation occurs for $\omega_2 T_{on} > \pi$.

a) $T_0^1 - T_1^1$ (M1) : Prior to T_0^1 , the MOSFET Q is off, and the rectifier diode D1 is conducting. At T_0^1 Q is turned on. The L_s current linearly falls until it reaches 0, where D1 is turned off. The L_r current starts to increase due to the resonance between L_r and C_r . Because of

controlled di/dt at turn-on, the turn-on loss of Q is negligible and the peak reverse current of D1 can be limited.

b) $T_1^1 - T_2^1$ (M2) : L_r current continues to make a resonance until the resonance brings its current to zero at T_2^1 . C_r voltage is decreased until its voltage becomes reversed peak value.

Using the initial C_r voltage of V_p and L_r current of zero at T_2^1 , the resonant current and the resonant voltage equations during M1 and M2 can be written as

$$\begin{aligned} i_{Lr}(t) &= \frac{V_p}{Z_2} \sin \omega_2 t \\ v_{Cr}(t) &= V_p \cos \omega_2 t \end{aligned} \tag{1}$$

c) $T_2^1 - T_3^1$ (M3) : D3 is turned off when the L_r current attempts to reverse. The operation of the circuit of this stage is identical to that of the basic boost converter.

d) $T_3^1 - T_4^1$ (M4) : At T_3^1 , Q is turned off. Cr is linearly charged by I_L to zero voltage. The energy trapped in Cr is transferred into the load during this mode.

e) $T_4^1 - T_5^1$ (M5) : When the capacitor Cr voltage becomes zero, diode D1 is turned on. The voltage across Q is limited by $V_o + V_{Cr}$. The Ls current builds up and the charging current into Cr goes down to zero. The induced voltage on Ls is absorbed in the snubber capacitor Cr. This stage finishes when the Ls current becomes I_L and Cr voltage is charged to its peak value at T_5^1 . The stress energy charge into Cr and the energy recovery into the load occur simultaneously during this mode.

Considering that the initial Ls current and Cr voltage are zeros at T_4^1 , the state equations during M5 are given :

$$\begin{aligned} i_{Ls}(t) &= I_L(1 - \cos \omega t) \\ v_{Cr}(t) &= Z_1 I_L \sin \omega t. \end{aligned} \quad (2)$$

f) $T_5^1 - T_6^1$ (M6) : This interval is identical to the freewheeling stage of the basic boost converter. During this stage, energy transfer from source to load occurs. At T_6^1 , Q is turned on again, starting another switching cycle.

B. Region - 2 Operation ($0 < \omega_2 T_{on} < \pi$)

The sequence of topological modes in Region - 2 operation are M1, M2, M7, M5, and M6. M1 and M6 of Region - 2 operation are similar to those of Region - 1 operation.

a) $T_1^2 - T_2^2$ (M2) : Lr current continues to make a resonance until Q is turned off. The Cr voltage is reduced to negative value at T_2^2 when $\omega_2 T_{on}$ varies from $\pi/2$ to π . For $\omega_2 T_{on} \leq \pi/2$, the Cr voltage is reduced to positive value at T_2^2 .

For the interval $T_0^2 - T_2^2$, the state equations of LrCr tank in Region - 2 operation can be expressed as (1) of Region - 1 operation.

b) $T_2^2 - T_2^2$ (M7) : At T_2^2 , Q is turned off, and its

voltage is limited by $V_o + V_{Cr}$ due to the conduction of D2. The energy stored in the inductor Lr is directly transferred into the load. Lr current goes down to zero at T_3^2 . The input current goes into the load through Ls - D1 or Cr - D2. For $\pi/2 < \omega_2 T_{on} \leq \pi$, the input current flows entirely via Cr - D2 path until the Cr voltage is charged by I_L to zero. When the value of Cr voltage is greater than zero, D1 is turned on.

c) $T_3^2 - T_4^2$ (M5) : The Ls current builds up until it reaches I_L at T_4^2 . The charging current into Cr gradually goes down to zero and the Cr voltage reaches V_p .

During the conduction of both D1 and D2, the Ls current and the Cr voltage can be expressed as the following :

$$\begin{aligned} i_{Ls} &= \frac{V_{Cr}(0)}{Z_1} \sin \omega t + I_L(1 - \cos \omega t) \\ v_{Cr}(t) &= V_{Cr}(0) \cos \omega t + Z_1 I_L \sin \omega t \end{aligned} \quad (3)$$

where the initial Ls current is zero and $V_{Cr}(0)$ is the Cr voltage at the start of D1 conduction. Since $V_{Cr}(0)$ is not less than zero, $V_{Cr}(0)$ can be derived from (1) as

$$\begin{aligned} V_{Cr}(0) &= 0, \text{ for } \pi/2 < \omega_2 T_{on} \leq \pi \\ \text{and } V_{Cr}(0) &= V_p \cos \omega_2 T_{on}, \text{ for } 0 < \omega_2 T_{on} \leq \pi/2. \end{aligned} \quad (4)$$

When $\omega_2 T_{on}$ varies from $\pi/2$ to π , the equation (3) is equal to (2). At the end of M5, the Ls current and the Cr voltage can be written as

$$\begin{aligned} I_L &= \frac{V_{Cr}(0)}{Z_1} \sin \omega t_{off} + I_L(1 - \cos \omega t_{off}) \\ V_p &= V_{Cr}(0) \cos \omega t_{off} + Z_1 I_L \sin \omega t_{off} \end{aligned} \quad (5)$$

where t_{off} is the transition time of Ls current from 0 to I_L for $0 < \omega_2 T_{on} \leq \pi/2$.

IV. Operation Characteristics

A. Overshoot voltage across Q

When Q is turned off, it experiences a voltage in excess of the output voltage due to the induced voltage across L_s . L_s current builds up until it reaches the input current I_L at the end of M5. At this point, the Cr voltage is charged to a peak value V_p .

From (2) and (3), the overshoot voltage V_p can be derived as follows :

$$V_p = Z_1 \cdot I_L, \text{ for } \pi/2 < \omega_2 T_{on}$$

$$\text{and } V_p = \frac{Z_1 \cdot I_L}{\sin \omega_2 T_{on}} \text{ for } 0 < \omega_2 T_{on} \leq \pi/2. \quad (6)$$

The overshoot voltage is normalized with respect to $Z_1 \cdot I_L$, and the normalized voltage is plotted in Fig. 6. The normalized overshoot voltage across the main switch is reduced to 1 as $\omega_2 T_{on}$ varies from zero to $\pi/2$, and then it is fixed at 1 for $\omega_2 T_{on} > \pi/2$.

B. Peak Lr current

When Q is turned on, apart from taking of the input current, it also sees the Lr current and the diode reverse recovery current. The Lr current reaches a peak value during M2.

From (1), the peak Lr current I_p can be expressed as

$$I_p = \frac{V_p}{Z_2}, \text{ for } \pi/2 < \omega_2 T_{on}$$

$$\text{and } I_p = \frac{V_p}{Z_2} \sin \omega_2 T_{on}, \text{ for } 0 < \omega_2 T_{on} \leq \pi/2 \quad (7)$$

Substituting (6) into (7) gives

$$V_p = \frac{Z_1 \cdot I_L}{Z_2} = \sqrt{\frac{L_s}{L_r}} \cdot I_L \quad (8)$$

The peak Lr current is directly proportional to the input current. The proportional coefficient is determined by the square root of ratio of the current limiting turn-on inductor L_s to the resonant tank inductor L_r .

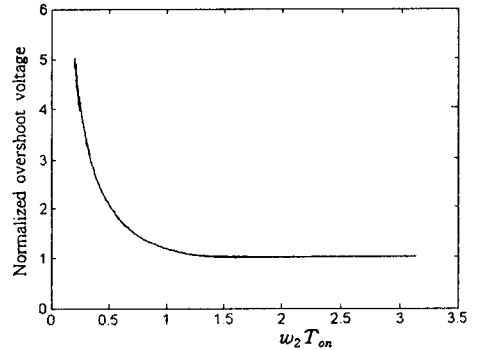

Fig. 6. Normalized overshoot voltage as a function of $\omega_2 T_{on}$.

C. Turn-off transition time

When Q is turned off, the input current flows into the load through Cr - D2 or L_s - D1 path. When Cr voltage is negative, which may occur for $\omega_2 T_{on} > \pi/2$, the current goes entirely via Cr - D2 path. When Cr is charged by I_L to zero, D1 is turned on. Then, Lr current builds up until it reaches I_L . When Lr current is equal to I_L , the turn-off transition is ended.

$$a) \pi/2 < \omega_2 T_{on}$$

From the voltage equations of (1) and (6), the Cr voltage at the end of conduction period of Q can be written as

$$V_{Cr}(T_{on}) = Z_1 \cdot I_L \cos \omega_2 T_{on}, \text{ for } \pi/2 < \omega_2 T_{on} \leq \pi$$

$$\text{and } V_{Cr}(T_{on}) = -Z_1 \cdot I_L, \text{ for } \pi < \omega_2 T_{on}. \quad (9)$$

Using this equation, the charging time of Cr by I_L to zero when Q is turned off can be derived as

$$t_c = -\frac{1}{\omega_1} \cos \omega_2 T_{on}, \text{ for } \pi/2 < \omega_2 T_{on} \leq \pi$$

$$\text{and } t_c = \frac{1}{\omega_1}, \text{ for } \pi < \omega_2 T_{on}. \quad (10)$$

From (2), the transition time for changing the flow of input current from Cr - D2 to L_s - D1 is $\frac{1}{\omega_1} \frac{\pi}{2}$. Therefore, the total turn-off transition time t_{off} , which is the time interval of $T_3^1 - T_5^1$ for the typical Region - 1 waveform of Fig. 3 and $T_2^2 - T_4^2$ for the typical Region - 2 waveform of

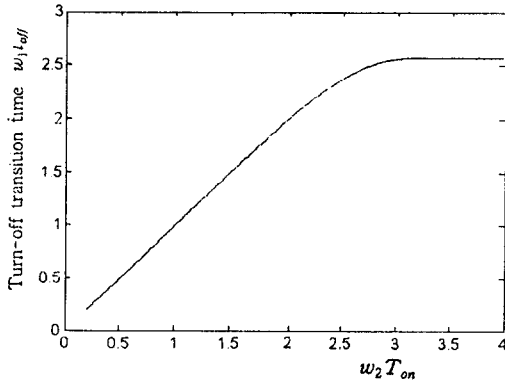

Fig. 7. The turn-off transition time w_{1toff} as a function of w_2T_{on} .

Fig. 4, can be expressed as

$$w_{1toff} = -\cos w_2T_{on} + \frac{\pi}{2}, \text{ for } \frac{\pi}{2} < w_2T_{on} \leq \pi$$

$$\text{and } w_{1toff} = 1 + \frac{\pi}{2}, \text{ for } \pi < w_2T_{on}. \quad (11)$$

b) $0 < w_2T_{on} \leq \pi/2$

When Q is turned off, D1 is turned immediately on. From (4) and (6), the initial Cr voltage can be derived as

$$V_{Cr}(0) = Z_1 \cdot I_L / \tan w_2T_{on} \quad (12)$$

Substituting (12) into the current equation of (5) gives

$$w_{1toff} = w_2T_{on} \quad (13)$$

Using (11) and (13), the turn-off transition time w_{1toff} is plotted as a function of w_2T_{on} in Fig. 7. The turn-off transition time w_{1toff} varies from 0 to 2.57, depending on w_2T_{on} .

V. Experimental Results

A 100-kHz, 500W high-power-factor boost rectifier with the proposed energy recovery snubber has been implemented to demonstrate the operation. It is regulated at 375-V output with a 110-220 VAC input range. The power stage circuit diagram is given in Fig. 8, which is implemented in conjunction with a control circuit [7]. The diodes Dz and D4 are used

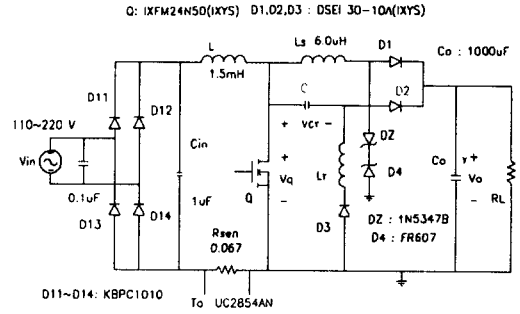

Fig. 8. Experimental boost rectifier circuit.

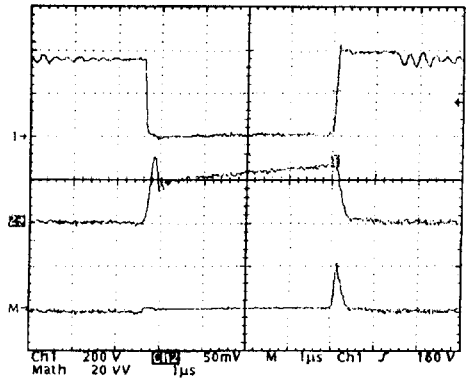

Fig. 9. Measured voltage (upper trace-200 V/div), current (middle trace-5 A/div), and loss (lower trace-2kW/div) waveforms of Q (time scale : 1μs/div).

limit the reverse voltage of D1 to $V_o + V_{Dz}$ when Q is turned on. The main switch Q is implemented with a MOSFET.

Fig. 9 shows the measured voltage, current, and loss waveforms of Q operating in Region - 2. The snubber components are chosen as : $L_s = 6.0\mu\text{H}$, $C_r = 0.47\mu\text{F}$, and $L_r = 110\mu\text{H}$. It can be seen that the turn-on loss of Q is negligible, but the turn-off loss is still significant due to high turn-off current. The turn-off current of Q can be reduced to I_L if the snubber is designed to be operated in Region - 1. However, the conduction loss of $L_r C_r$ tank in Region - 1 could be increased compared with that of the tank in Region - 2 due to the higher circulating current. As shown in the voltage waveform of this

figure, the measured turn - off transition time t_{off} is about $1.2\mu s$, and the measured T_{on} is $4.4\mu s$. Since ωT_{on} is 0.61, the theoretical t_{off} can be calculated from (13) as $1.03\mu s$. The small discrepancy between the measured and the theoretical t_{off} is mainly due to both the nonideal switching devices and the existence of stray impedance parameters in the experimental circuit.

The input ac voltage and current , which demonstrates the high power factor of proposed boost rectifier, are shown in Fig. 10. Fig. 11 shows the measured Region - 2 waveforms for the boost inductor current I_L , Lr current, and the voltage across Q at 120 Hz, which are also presented together with the ac input voltage. In this figure, the peak input voltage is 200 - V and the maximum I_L current is 5 - A. Using (8), the theoretical maximum peak Lr current can be calculated as 1.17 A. The measured Lr current coincides quite well with the theoretical one. When the boost converter is operating at 200 - V input voltage, the duty ratio of experimental boost converter is 0.467, and hence T_{on} is $4.67\mu s$. Using (6), the maximum overshoot voltage can be calculated as 29.6 - V, and the

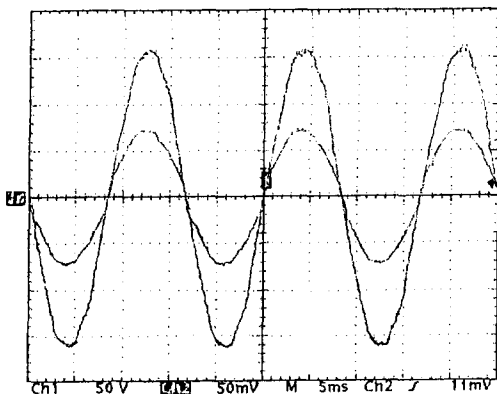
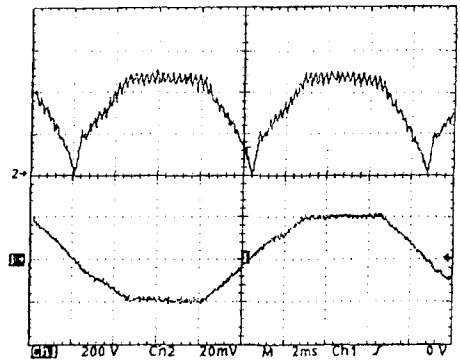

Fig. 10. Measured input voltage(outer trace-50 V/div) and current(inner trace5 A/div) wave forms(time scale : 5ms/div).

maximum V_q becomes 404.6 - V. The agreement between measured and theoretical overshoot voltage is good.

The measured efficiency of the implemented converter shows 96.5 % at high - line - input voltage and 91.5 % at low - line - input voltage in Region - 2 operation. The measured power factor is 0.99. If Q is an IGBT, the reduction of turn - off loss should be needed. When the proposed snubber is combined with the passive recovery snubber [8], the turn - off loss could be



(a)

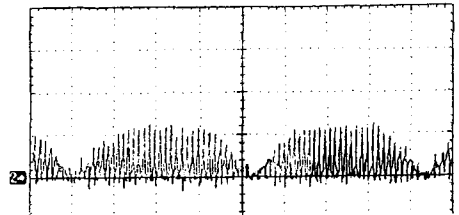

(b)

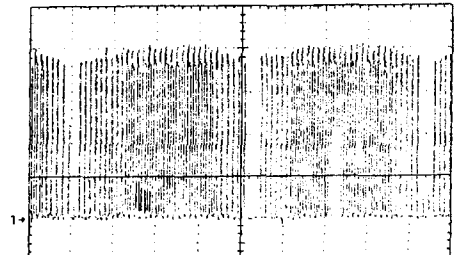

(c)

Fig. 11. Measured boost converter waveforms(time scale : 2ms/div). (a) I_L (2A/div) and V_{in} (200V/div), (b) Lr current (1A/div), and (c) V_a (100V/div)

minimised by controlling the voltage trajectory across the main switch from zero to clamp voltage.

VI. Conclusion

A passive energy recovery snubber for boost converter has been presented. The main switch Q of the boost converter, which is implemented with a MOSFET in this paper, is turned on with zero current and turned off with a limited voltage clamp. Therefore, the turn-on loss of Q is negligible, but the turn-off loss of the switch is still significant due to high turn-off current in Region-2 operation. The turn-off current of Q can be reduced to IL if the snubber is designed to be operated in Region-1. However, the conduction loss of LrCr tank in Region-1 could be increased compared with that of the tank in Region-2 due to the higher circulating current. If the main switch is constructed with an IGBT, the passive recovery snubber [8] can be added to the proposed snubber to control the rate of rise of its voltage from zero to the voltage clamp, and to reduce the turn-off loss to a minimum.

The operation analysis for the proposed snubber has been done. The overshoot voltage across the main switch is derived and normalized with respect to Z_1IL . The normalized overshoot voltage is reduced to 1 as $\omega_2 T_{on}$ varies from zero to $\pi/2$, and then it is fixed at 1 for $\omega_2 T_{on} > \pi/2$. The peak snubber inductor current is directly proportional to the input current. The proportional coefficient is determined by the square root of ratio of the current limiting turn-on inductor L_s to the resonant tank inductor L_r . The turn-off transition time t_{off} varies from 0 to 2.57, depending on $\omega_2 T_{on}$.

The high-power-factor boost rectifier with a passive energy recovery snubber is implemented to confirm the operation. The experimental

results show good agreement with the theoretical ones. The measured power factor is 0.99.

Acknowledgement

This work was supported by Korea Science & Engineering Foundation (KOSEF) under project 971-0912-072-2.

References

1. K. Chen, A. Elasser, and D.A. Torrey, "A soft switching active snubber optimized for IGBTs in single switch unity power factor three phase diode rectifiers," *IEEE Trans. Power Electron.*, vol. 10, no. 4, pp. 446-452, July 1995.
2. G.C. Hua, C.S. Leu and F.C. Lee, "Novel zero-voltage-transition PWM converter", *IEEE PESC Record*, pp. 55-61, 1992.
3. N. Backman and H. Thorsland, "A new light-weight 100A/48V three phase rectifier", *IEEE Intelec91 Record*, pp. 92-97, 1991.
4. G. Cali, "Harmonic distortion reduction schemes for a new 100A-48V power supply", *IEEE Intelec92 Record*, pp. 524-531, 1992.
5. M.G. Kim, "A new energy recovery snubber for boost converter", in the *Journal of Korean Institute of Power Electronics*, pp. 57-63, June 1997.
6. J.G. Kassakian, M.F. Schlecht, and G.C. Verghese, *Principles of Power Electronics*. Reading, MA: Addison-Wesley, 1991, chap. 24.
7. L. Dixon, "High power factor switching pre-regulator design optimization", *Unitrode power design seminar*, 1991.
8. S.J. Finney, B.W. Williams, and T.C. Green, "RCD snubber Revisited", *IEEE Trans. Ind. Applicat.*, vol. 32, no. 1, pp. 155-160, January/February 1996.