

## Recent Curriculum Development in the Early Childhood Geometry in Czech Republic<sup>1</sup>

KUČINA, FRANTIŠEK

Department of Mathematics, Pedagogical University, 500 03 Hraadec Králové,  
Czech Republic

The paper deals with some aspects of early childhood geometry in the Czech Republic. Children's first geometrical experiences come from real life. In our opinion, there exist four types of geometrical experience which can be called the partition of space, the filling of space motion in space and the dimension of space. We distinguish three levels of the mathematical learning process: a spontaneous level, an operational level and a theoretical level.

### CONTENTS

1. Stimuli and applications
  2. School possibilities and their realization
  3. Our contemporary conception
  4. Examples and illustration
- References

### 1. STIMULI AND APPLICATIONS

There are many phenomena in the life of man which historically contributed to the origination of geometry as an independent scientific field and which affect the formation of the geometrical component of education.

Let's take notice of some of them.

- a) The man lives, moves and creates in space. The physical and biological properties of environment are connected with the geometrical qualities of space which condition man's motion and activity, limit his possibilities and stimulate his production.
- b) The technical practice deals with many geometrical notions, for example: circle,

---

<sup>1</sup> Received March 5, 1997. Paper presented at the Seventh International Congress on Mathematical Education (ICME-7) which was held at Université Laval, Québec, Canada, August 17–23, 1992

ball, cube, cylinder, perpendicularity, parallelism, congruence, . . . The geometrical stimuli occur very often in nature. The laws of motion and growth express themselves in the shapes of natural formation, such as leaves, flowers, branches, etc.

- c) Some geometrical results also show certain aesthetics values. The point is especially in different forms of regularity, periodicity, congruence, similarity, etc.
- d) Representations and patterns of technical type usually have geometrical forms. Technical drawings are records of information in the geometrical language. The geometrical language finds utilization in the whole mathematics and in some other scientific fields. Very important are various graphical representations of numbers (e.g., on the number line) and various graphs and diagrams of sets, relations and functions. The geometry gathers stimuli from all of the above mentioned fields: almost all of these fields are spheres of geometrical applications.
- e) The logical construction of geometry as a scientific line is, of course, a very important basis of geometrical research.

## 2. SCHOOL POSSIBILITIES AND THEIR REALIZATION

The main problem of school geometry is the question if the basis of instruction is a ready mathematical field elementary geometry, or if the instruction should come our of the non-mathematical stimuli.

Is the system of mathematical theorems which we have to adapt to the pupils, or the world of space experience of the pupils the basis of instruction?

In Czechoslovakia we made rich and, of course, negative experience with the first of the above mentioned approaches. The geometry introduced to our schools since 1967 recasted Euclidean geometry by using three undefined entities: points, segments and incidence.

The pupils' work with points and segments in the three dimensional space brought some troubles. The modeling of points by means of small balls led to the idea of the segments as a set with the finite number of elements (see Figure 1).



*Figure 1.* A set with the finite number of elements

The definition of the triangle was unnatural: Triangle ABC is a set of all points X of all segments AY where Y is an arbitrary point of the segment BC.

Each point of the triangle in space is its boundary point etc. (see Figure 2).

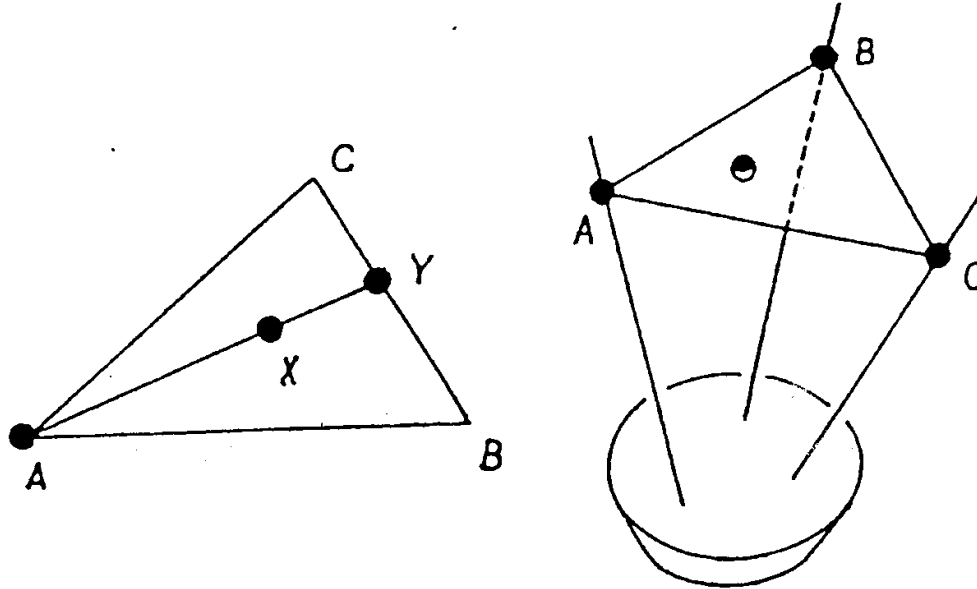

*Figure 2.* Each point of the triangle

Another negative feature of this approach to geometry was the fact that not only the stimuli, but also the application of geometry were almost exclusively theoretical. Such a self-generating discipline was necessarily formal and in the school also verbal.

The second possibility how to construct the geometry course is in the utilization of practical stimuli and spatial experience of pupils.

This idea is not new-it was theoretically formulated as a problem by Freudenthal (1981) at ICME-4 in 1980:

“Is it possible to teach geometry by having the learner reflect on his spatial intuition?”

On the basis of our experiments I am convinced that the geometry teaching of pupils aged 6–12 years can and must be supported by their spatial experience. This experience is to be systematically developed in both practical and theoretical sense. In our conception geometry is understood as a method of getting answers to questions arousing curiosity of pupils. We attempted to establish a course of geometry supported by direct pupil's experience, which is gradually developed by means of various kinds of work. At the first stage the idea of our experiments was influenced by the group IOWO (1976)

from the Netherlands.

### 3. OUR CONTEMPORARY CONCEPTION

Our contemporary conception is influenced by all of the above mentioned aspects, the structural aspect lying on the margin of our interest.

We would like to emphasize three dimensions of our approach to geometry as shown in Figure 3.

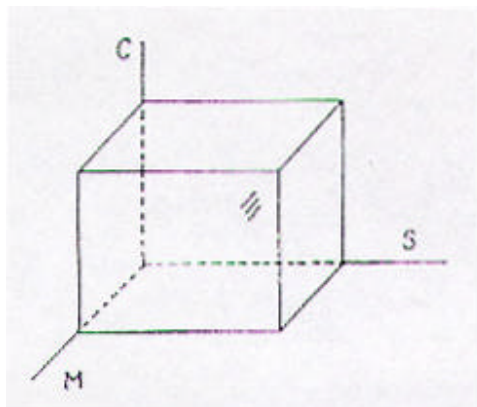

- C: The content of geometrical subject matter.  
 S: Its didactical structure.  
 M: Methods of its presentation at school.

Figure 3. Three dimensions

The content of geometrical subject matter is influenced by the tradition of our school by the needs of practice and by the preparation for future education.

We can divide it into three parts:

1. Qualities of geometrical figures (such as cube, sphere, ball, square, triangle, segment, straight line, angle, . . . )
2. Measurement of geometrical figures and counting of perimeters areas and volumes. On this occasion pupils learn the important continuity of geometry and arithmetic.
3. Geometrical constructions as outstanding field for the development of geometrical imagination. In addition to technical drawing, we also draw by hands some geometrical figures such as triangle, square, cube, circle, . . . We emphasize problems connected with the pupil's life and results having some aesthetical values.

The didactical structure of geometry is not based on its logical structure (e.g., genetically and psychological aspects).

On the basis of our long term study we formulated the following didactical structure of primary school geometry:

1. Partition of space.
2. Filling of space.
3. Motion in space.

Therefore we respect questions connected with dimension of space (4.), especially problems of geometrical figure mapping. The theoretical basis for partition of the plane is the Jordan curve theorem, the practical stimuli connected with partition of space are familiar from every day practice. On the idea of partition of the plane it is possible as show in Figure 4 to introduce a lot of geometrical notions in a natural way (e. g., polygon, circle, . . . )

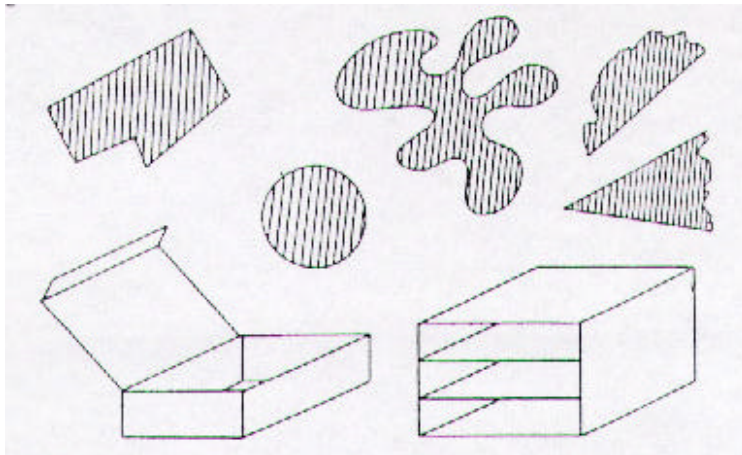

Figure 4. Geometrical Notions

The process of measurement is connected with paving or tessellation of a part of the plane (segment, space). The motion in space is well known to pupils from the physical world, the results of motion recording lead to drawing of some geometrical figures and to construction of some solids (see Figure 5).

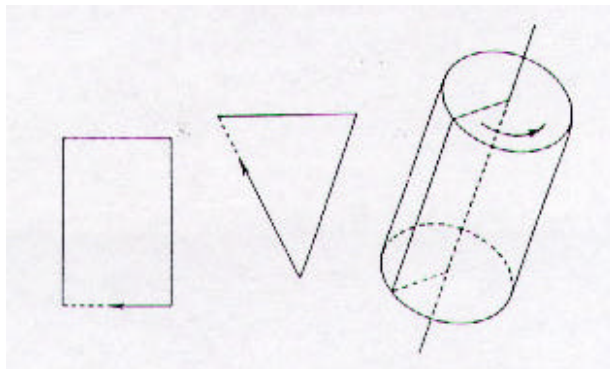

Figure 5. Construction of some solids

Together with M. Hejný we distinguish three levels of the mathematics learning process:

1. Spontaneous level. (Forming of images).
2. Operational level. (The images are further developed by means of various activities).
3. Theoretical level. (Its results are mathematical notions and proofs).

The levels of learning are not separated in the practice. The thinking of pupils is from the very beginning connected with performing operations, experiments, transformations, . . . The intuition, which has a character of spontaneous approach, is very important also in the theoretical level of learning.

In the process of education at primary school a very important role is played by the representational problems formulated by J. A. Comenius and J. Bruner. For example the natural numbers are represented not only by sets of balls, dots, squares, . . . but also by the number line and various symbols. The geometrical figures are represented not only by its models (cubes, blocks, . . . ), but also by means of various pictures and diagrams.

#### 4. EXAMPLES AND ILLUSTRATIONS

In this part of my paper I would like to give some example from Czech textbooks and working sheets (cf. Kittler 1991; Kittler & Kučina 1991a; Kittler & Kučina 1991b) which are determined for the first three grades of Primary school.

Further examples from the prepared textbook for the fourth grade and the exercise book are added.

Some stimuli in this part are from Radatz & Rickmeyer (1991).

APPENDIX

Draw the leaves.



Draw flowers:

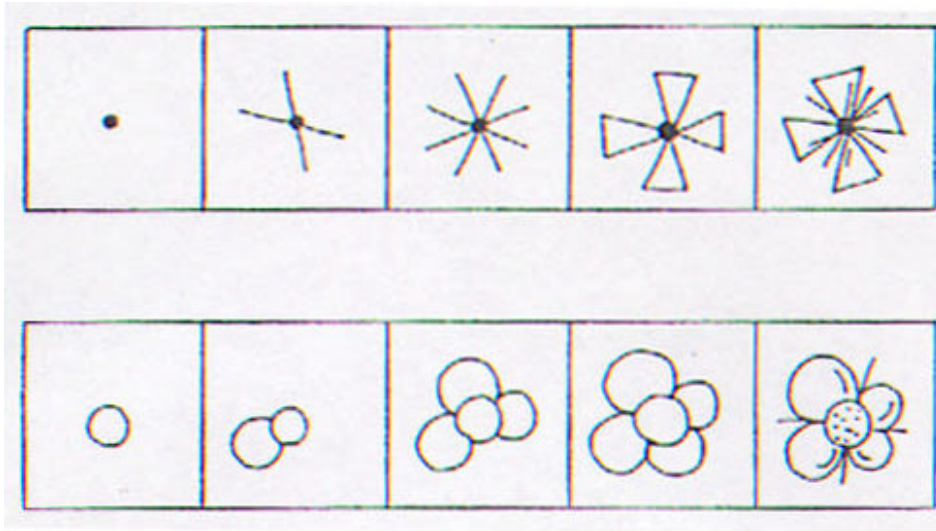

Colour some of them.

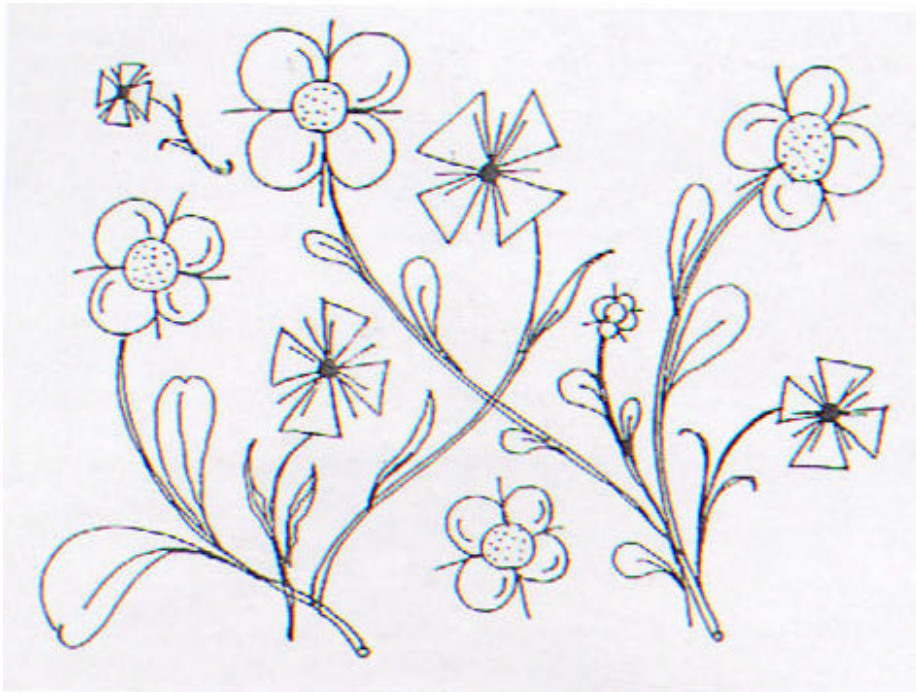



Draw the letter K.



Complete embroidery.

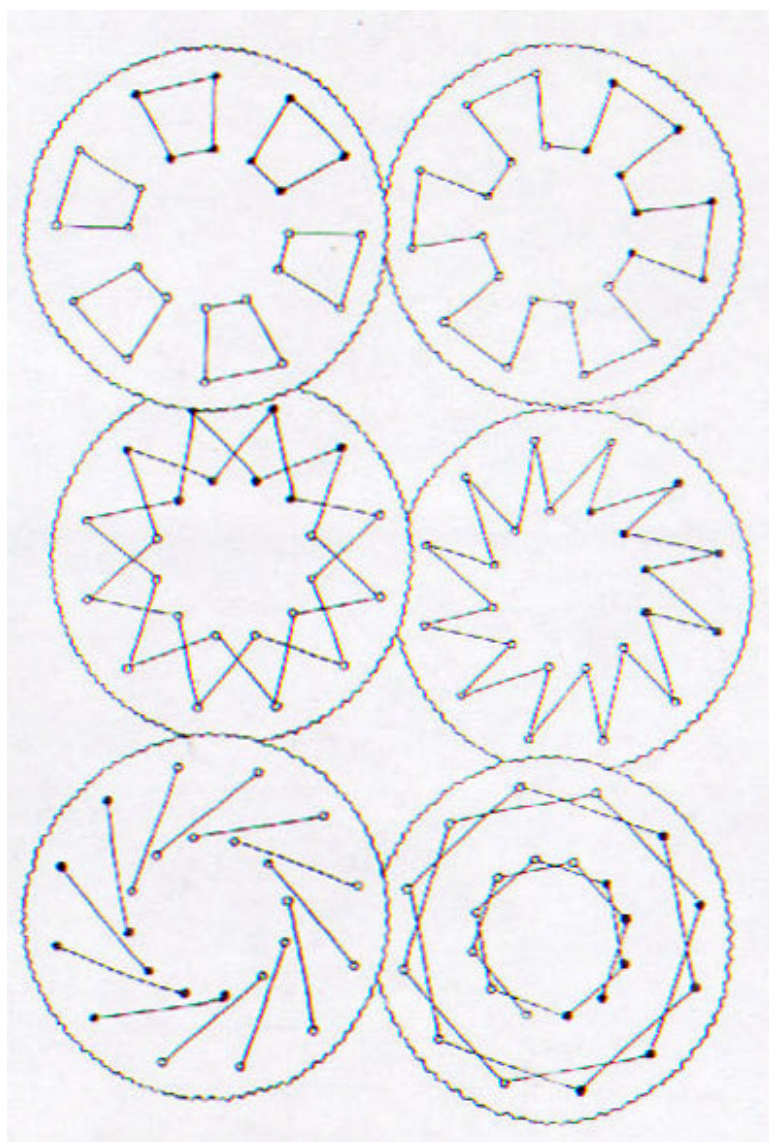

How the tree grows.

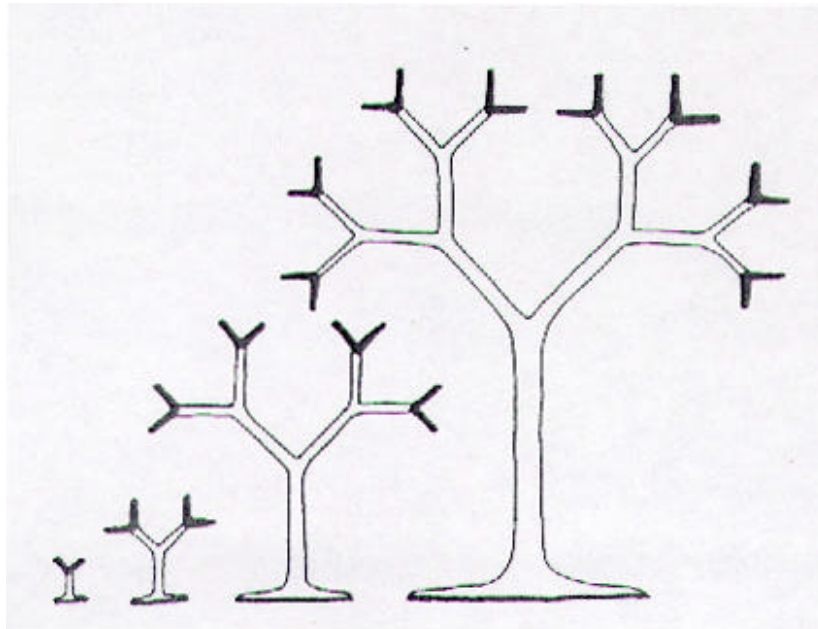

Draw the tree.

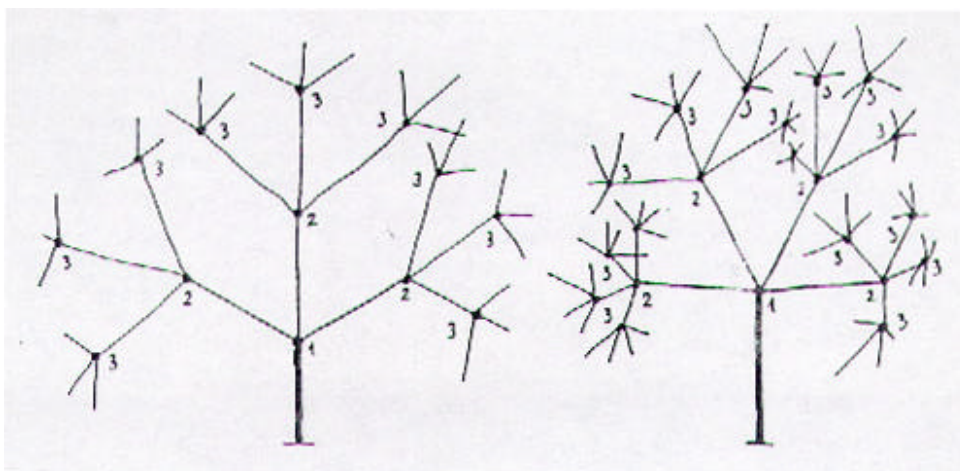

Colour the flags.

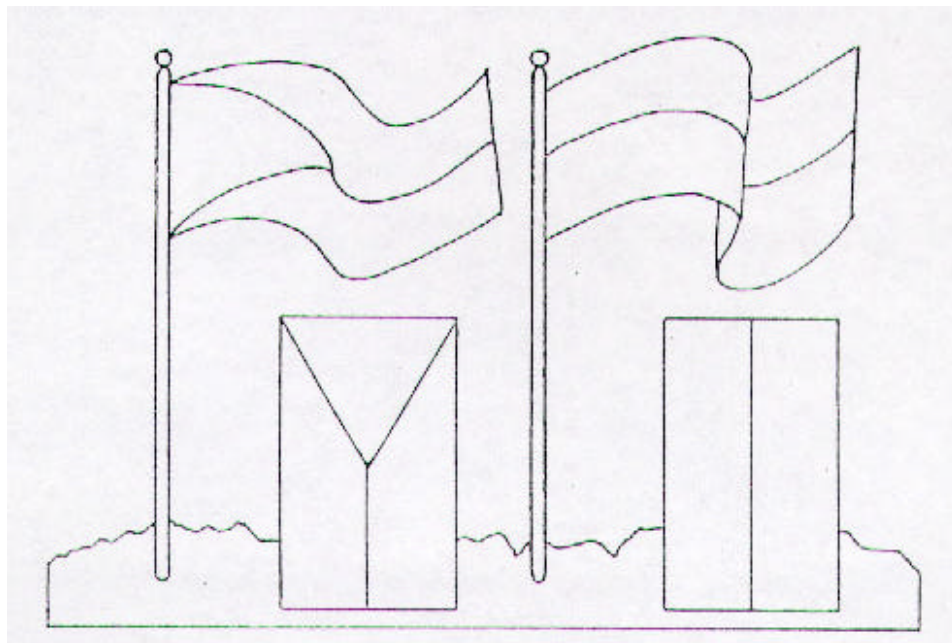

Draw various flags.

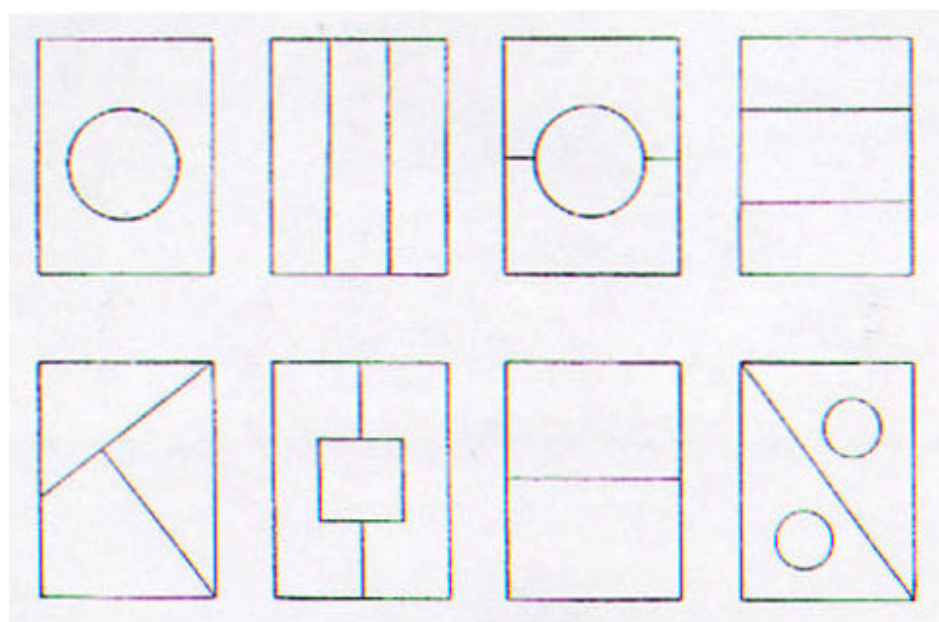

Geometry and practice.

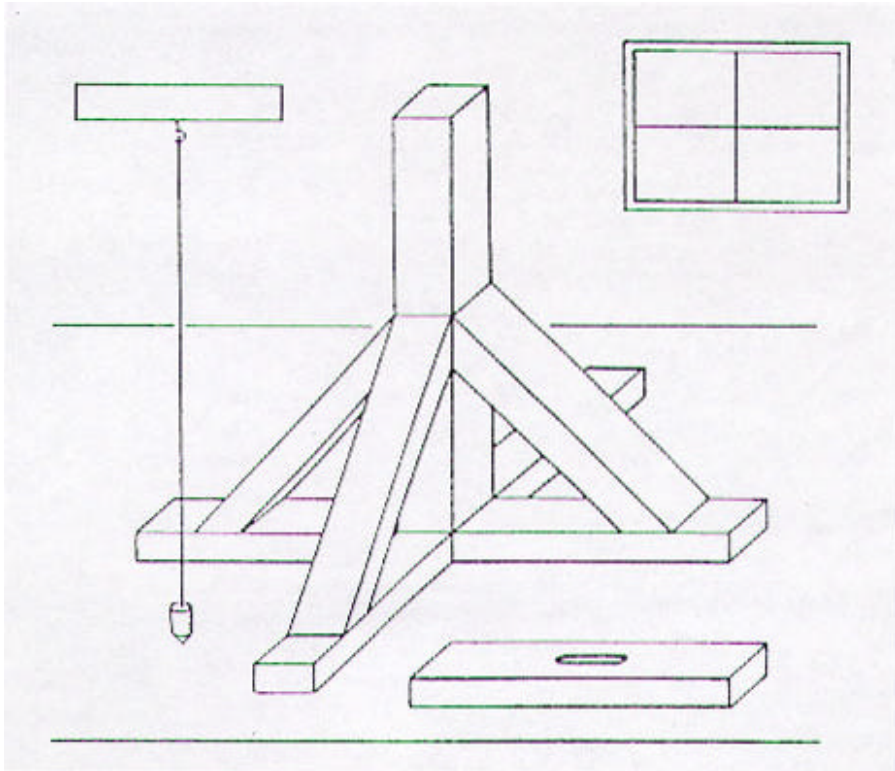

Draw the hexagon.

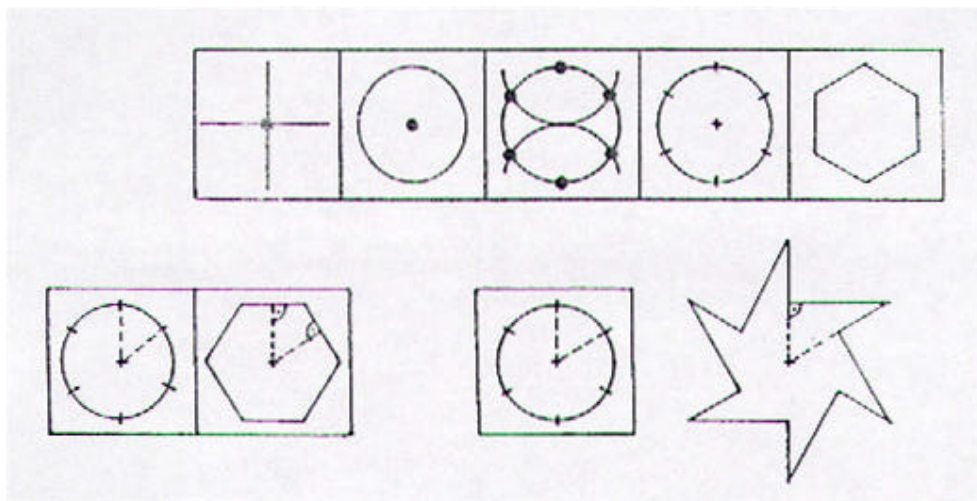

Traces on snow.

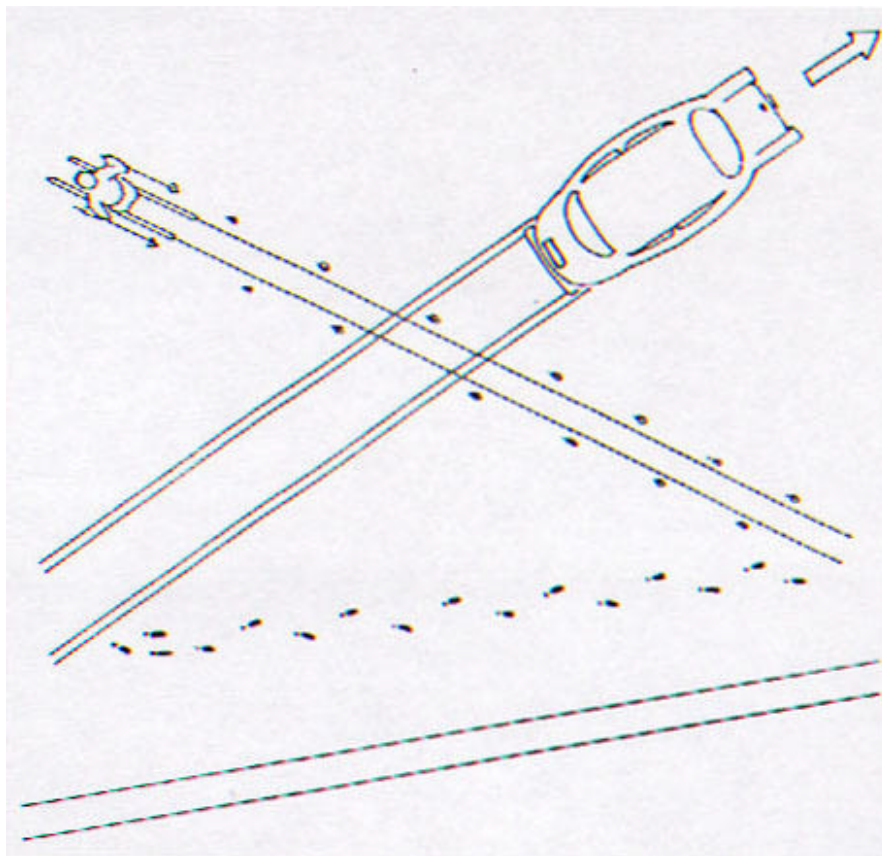

Draw the crossings.

Parallel lines

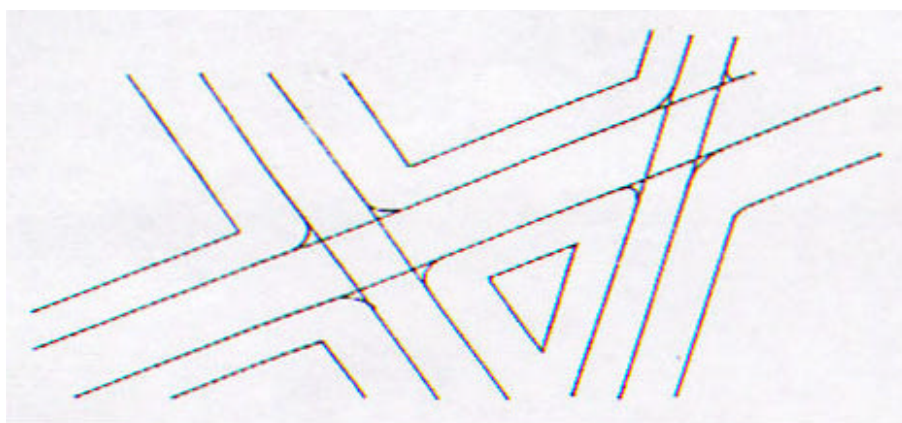

Measurement of segments.

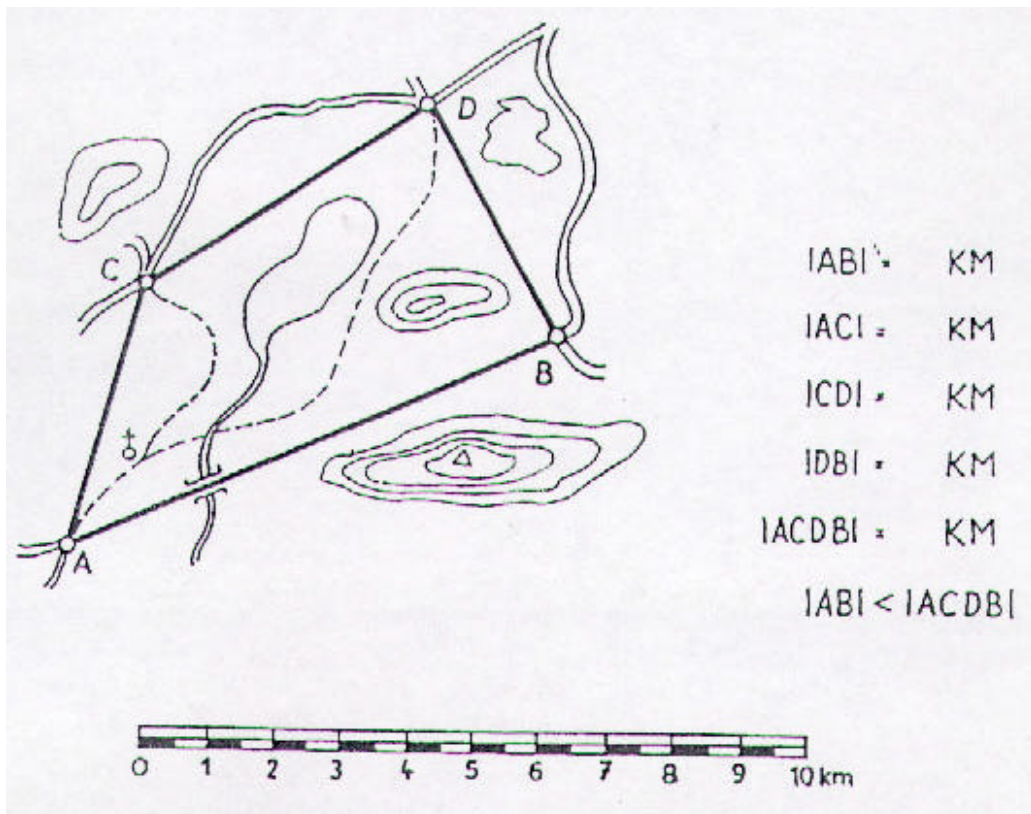
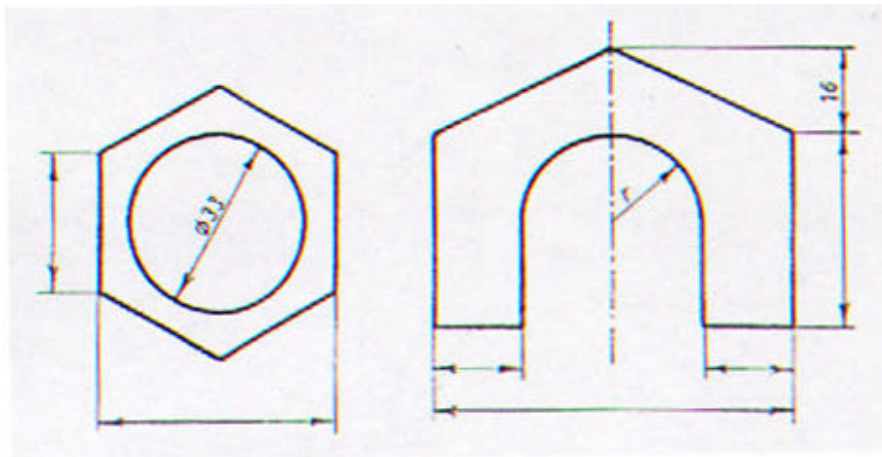





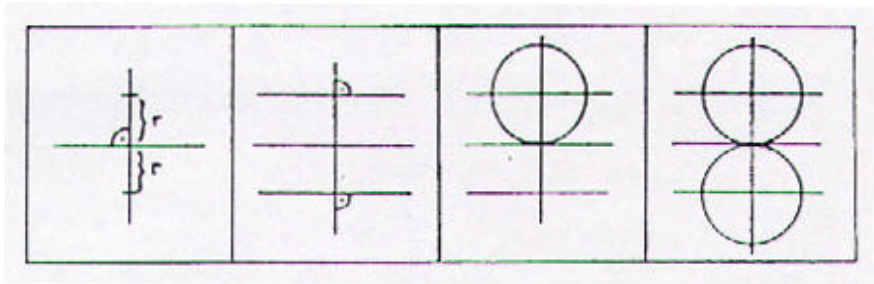

Draw a letter or digit.

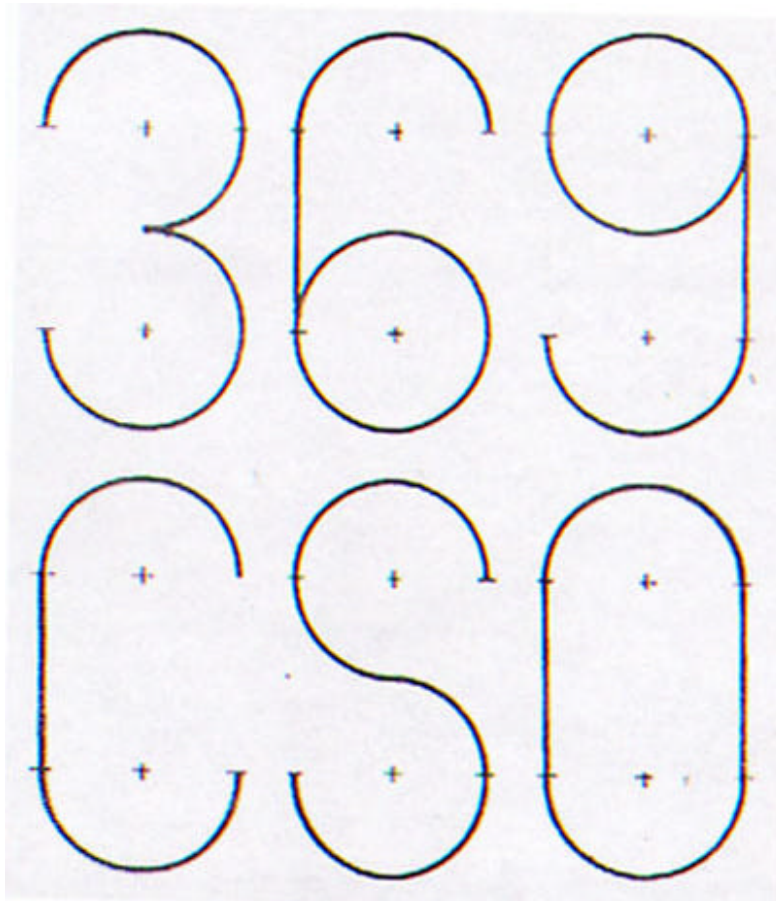

How many cubes are there?

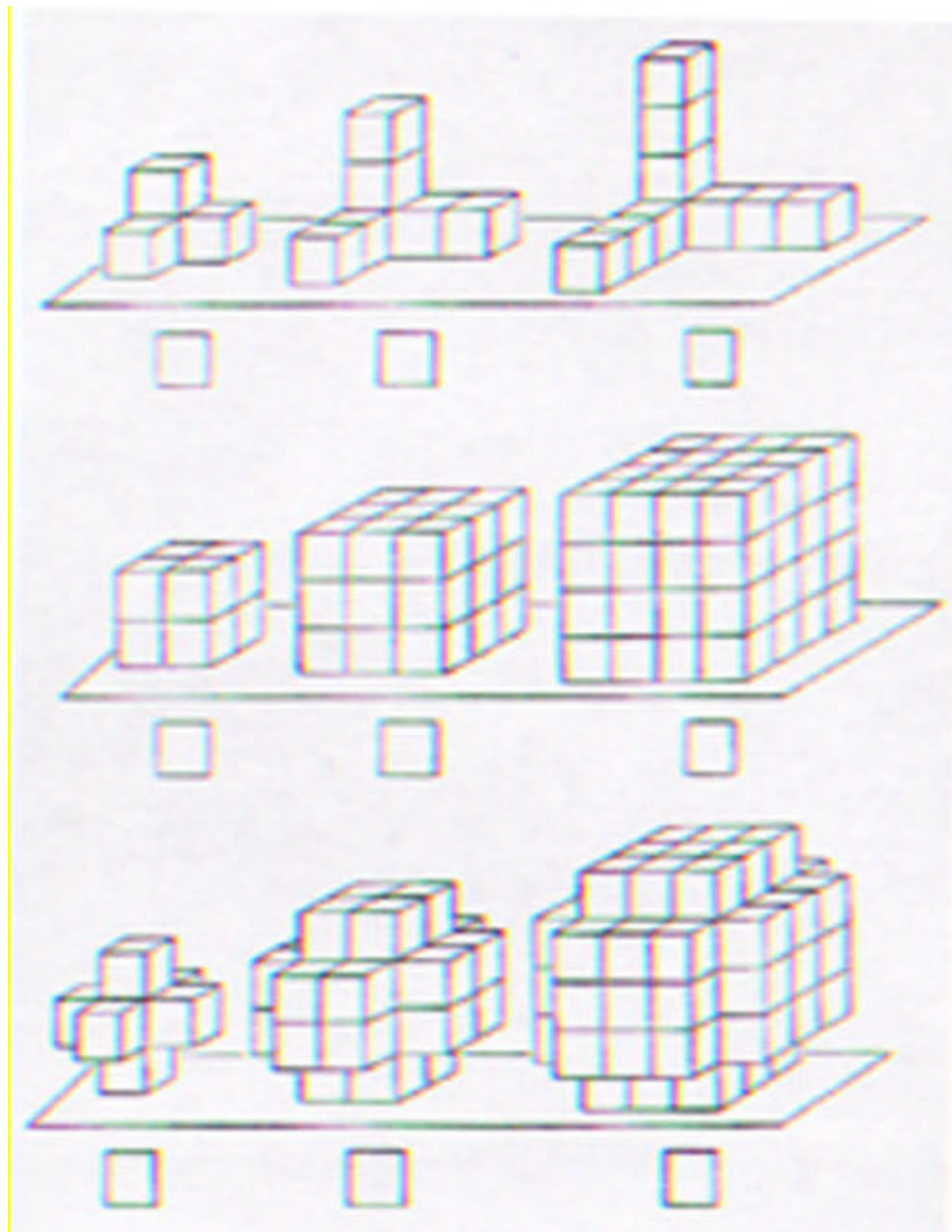

## REFERENCES

- Kittler, J. (1991): *Mathematika 1*. Prague: SPN.
- Kittler, J. & KUØINA, F. (1991a): *Mathematika 2*. Prague: SPN.
- Kittler, J. & KUØINA, F. (1991b): *Mathematika 3*. Prague: SPN.
- Radatz, H. & Rickmeyer, K. (1991): *Handbuch für den Geometrieunterricht an Grundschulen*. Hannover: Schroedel.
- Komenský, J. A. (1946): *Didaktika analytická*. Prague: Samcovo Nakladatelství .
- Freudenthal, H. (1981): *Major Problems of Mathematical Education*. Educational Studies in Mathematics, 12
- Bruner, J. S. (1966): *Towards a Theory of Instruction*.
- IOWO (1976): *Five Years of IOWO*. Dordrecht, Holland: D. Reidel.