

Development of Microbial Fuel Cells Using *Proteus vulgaris*

Namjoon Kim, Youngjin Choi, Seunho Jung,* and Sunghyun Kim*†

Department of Microbial Engineering, Konkuk University, Seoul 143-701, Korea

†Department of Chemistry, Konkuk University, Seoul 143-701, Korea

Received September 8, 1999

Microbial fuel cells comprising the microorganism *P. vulgaris*, thionin as a mediator, and various mono- and disaccharides in an anodic compartment have been developed. A cathodic compartment containing a Pt electrode and $\text{Fe}(\text{CN})_6^{3-}$ was separated from an anode by the Nafion membrane. From absorbance-time measurements, it was found that the absorbance of thionin was not altered by the addition of *P. vulgaris*, even in the presence of sugars. However, thionin was effectively reduced when *P. vulgaris* was present. These results differ substantially from the case of safranin O, a phenazine-derivative, indicating that thionin takes up electrons during the metabolic oxidation processes of carbohydrates. Maximum fuel cell efficiency was observed at 37 °C, optimum temperature for the growth of *P. vulgaris*, and 0.5 V cell voltage was obtained, which indicates that the metabolism of the microorganism directly affects the efficiency. Thionin concentration was closely related to cell performance. When the charging-discharging characteristics were tested with glucose, galactose, sucrose, maltose, and trehalose as carbon sources, galactose was found to give the highest coulombic efficiency. Cell performance was almost fully recovered with only small degradation when glucose and sucrose were used in the repetitive operation. Current was maintained nearly twice as long for sucrose than in the case of glucose.

Introduction

Recently, much attention has been paid to fuel cells as next-generation energy devices. Fuels are directly converted into electrical energy in fuel cells at high efficiency with emission levels far below the most strict regulations.¹⁻³ Since chemical combustion is not involved, fuel cells are environmentally friendly, and their efficiency is not limited by the Carnot cycle. Also, being small and modular they are easily adaptable on-site to a wide range of power requirements. There are many types of fuel cells. Usually hydrogen and oxygen are supplied as fuels to the anode and the cathode, respectively, where they undergo electrochemical reactions, producing electricity and water as by-products.^{4,5} Distinguished by the type of electrolytes, they could be classified as alkaline fuel cells (AFC), phosphoric acid fuel cells (PAFC), molten carbonate fuel cells (MCFC), and solid oxide fuel cells (SOFC). Going from AFC to SOFC, the operation temperature increases from 70 °C to ca. 1000 °C.

One of the most difficult and important technologies in fuel cell development is oxygen reduction at the cathode. The overpotential of oxygen reduction is very high at ordinary electrodes. Although platinum is one of the most efficient oxygen reduction catalysts, the high cost and the limited reserves prevent it from being used on a large scale. The poisoning effect of the Pt surface by the incomplete oxidation of fuels is another obstacle to overcome when hydrocarbons are used in an anode. Therefore, much effort has been poured into the development of electrocatalysts as platinum-substitutes. Usually a higher efficiency and no-poisoning effect are achievable by operating at high temperature. However, electrocatalysts may not be thermally and mechanically stable, and corrosion could shorten their

life time.⁸⁻¹⁰

Microbial fuel cells using living microorganisms have been studied during the last several decades.¹¹⁻¹⁷ In microbial fuel cells, the anodic reaction is replaced by the electrochemical processes in the microorganism's metabolism. Because of the technical difficulties, such as low current density and strict reaction conditions, microbial fuel cells are still in their infancy. But comparing with inorganic fuel cells, they demonstrate the following advantages: i) They are very environmentally friendly. For example, electricity could be produced from the decomposition of wastes by microorganisms. ii) Since microorganisms can utilize any carbon-bearing substance, in principle, a variety of fuels can be used for microbial fuel cells, whereas fuels for inorganic fuel cells are limited to several candidates. The abundance of such fuels is an additional advantage. iii) Since metabolism in a microorganism is one of the most efficient processes in nature, the poisoning effect could be avoided. Other advantages have also been pointed out.¹⁸

Despite these advantages, a way to anchor microorganisms to the electrode surface without losing microbial activities is still lacking. Also, the optimum conditions for the microorganisms to grow should be met in order to maintain long-term operation. Also, the mediator, an electron shuttle, should not decompose, or undergo any other reactions other than the transfer of electrons.

In an anodic compartment of microbial fuel cells, microorganisms oxidize fuels such as carbohydrates to produce electrons. Electrons, in turn, are captured by the oxidized mediator and transferred to the anode. At the anode, the mediator is reoxidized by delivering electrons and ready to take electrons from the microorganism. This, in combination with a suitable cathode, produces electrical energy. A series

of these reactions is possible as long as substrate is supplied to the microorganisms. The role of a mediator should be emphasized here. Without a mediator, the efficiency has been found to be quite low. The ideal mediator has the following properties. i) It should display reversible redox reactions to function as an electron-shuttle. ii) A low formal potential. The lower the formal potential, the larger the cell voltage since it is the difference between the cathode and anode potentials. iii) It should have appreciable solubility in an aqueous solution and stability. iv) Most important, it should freely penetrate the cell membrane to capture electrons. Therefore the selection of a mediator and a microorganism is crucial to the development of a microbial fuel cell.

In this work, we constructed microbial fuel cells using *P. vulgaris* as a microorganism, thionin, as a mediator, and various mono- and disaccharides as a substrate, and tested the performance under various operation conditions.

Experimental Section

Preparation of microorganism. *P. vulgaris* (ATCC 6059) was bought from KCTC (Korean Collection for Type Cultures) and maintained on a nutrient agar plate at 4 °C. The experimental culture was aerobically grown in a nutrient badge containing 10 g/L of NaCl, 10 g/L of trypton, and 1.8 g/L of glucose at 37 °C. This culture was daily subcultured with 5% inoculum for three days, and the cells were harvested by centrifuging at 3000 g and then washed three times with 0.05 M phosphate buffer of pH 7.0. This procedure was carried out at 4 °C. The washed microorganisms were suspended in the phosphate buffer and the weight was adjusted to 10 mg/mL by dry mass. The cell concentration was determined by UV-visible spectrophotometry and a cell colony counting method.

Reduction of thionin. A double-beam UV-visible spectrophotometer (Hitachi U-2000) was employed to monitor the thionin reduction by *P. vulgaris* as a function of time. Glucose solution, whose final concentration was adjusted to 0.33 mM, was added to the mixture of 1 mL of the cell suspension and 1 mL of thionin solution of 1 mM. The absorbance change was monitored for 15 min at 598 nm, the maximum absorption wavelength of thionin.

Construction of microbial fuel cells. Our cells have the following structure.

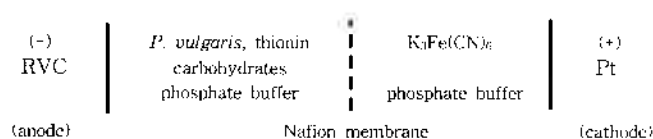

The cell body was made of poly(methylmethacrylate) and each electrode compartment has a capacity of $45 \times 45 \times 15 \text{ mm}^3$ (Figure 1). Reticulated vitreous carbon (RVC) was used as an anode. RVC has a physical structure that gives microorganisms and mediators easy access to the surface by providing an open network and high surface area. RVC was washed with 75% alcohol and deionized water and dried at

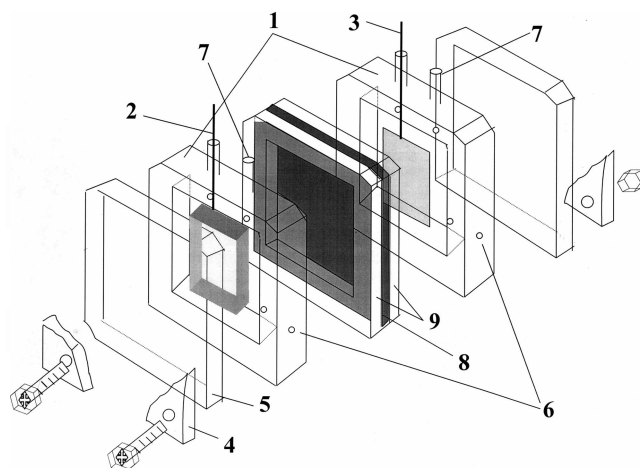

Figure 1. Schematic diagram of the fuel cell assembly: (1) Electrode compartments, (2) RVC anode, (3) Pt cathode, (4) end plate, (5) backing plate, (6) inlets for nitrogen, (7) inlets for solution injection, (8) ion-exchange membrane, and (9) silicon rubber gasket.

80 in an oven to remove any remaining microorganisms and mediators and then placed in a buffer solution (0.1 M phosphate) before use. A platinum plate of $40 \times 40 \times 0.5 \text{ mm}^3$ was used as cathode material. The catholyte, 0.1 M ferricyanide, would be reduced to ferrocyanide. The Pt plate was cleaned with a 1 : 1 mixture of concentrated sulfuric and nitric acids for 30 min and washed with deionized water before use. The anodic and cathodic compartments were separated by a Nafion membrane (Aldrich) and sealed by 1.5 mm-thick silicon rubber gaskets placed between membrane and cell body. Each compartment had inlets for the electrical contact of the electrodes, gas and solution input, and an outlet for the gas exit. During the experiments nitrogen was flowed through the cell to gently agitate the solution and prevent oxygen from entering. The pH of both anolyte and catholyte was maintained at 7.0. The operation temperature was maintained constant in the water bath.

Discharging procedure. Each compartment of the cell was filled with a buffer solution and purged with nitrogen. Next 1 mL of *P. vulgaris* suspension whose dry weight was 10 mg was added through the inlet of the anodic compartment. Then the thionin stock solution was injected until the concentration was 0.4 mM, followed by the addition of 0.5 mL of 1 mM carbon source. The cell was discharged below 0.1 V through the external 1 k \cdot ohm resistor before monitoring the discharge curve. The change in cell voltage was recorded by a strip chart recorder as a function of time immediately after injecting the 0.5 mL of carbon source. Carbon sources used in the experiments were mono- and disaccharides such as glucose, galactose, sucrose, maltose, and trehalose. Generally, the cell voltage rapidly increased when the carbon source was added and reached the steady-state value. After consuming all the substrate, the cell voltage dropped to zero. The coulombic efficiency was defined as the percentage charge obtained from the integration of the discharge curve, compared with the theoretical charge calcu-

lated from the complete oxidation of the substrate. The cell performance was studied by changing reaction temperature, thionin concentration, and carbon source. Also charging-discharging characteristics were obtained with glucose and sucrose.

Results and Discussion

Reduction of thionin. The thionin reduction by *P. vulgaris* was performed both in the absence and presence of glucose. The absorbance change at 598 nm, the maximum absorption wavelength of the oxidized form, was monitored as a function of time. When reduced, thionin does not absorb in the visible region. No change in absorbance was observed in the absence of glucose as a fuel. As shown in Figure 2, with a small amount of glucose, the absorbance did not show any appreciable change, indicating thionin was not reduced. However, an abrupt decrease was observed 5 min after 1 μmol of glucose was added. This clearly indicates that thionin reduction occurred by accepting electrons produced from the oxidation of glucose. Thionin freely flows in and out of the cell membrane, although it is not certain which metabolic pathway is involved. Since the metabolic action of a microorganism takes time, the reduction does not occur immediately after the addition of glucose.

The same procedure was carried out for safranin O, a phenazine-derivative, as another possible redox mediator (Figure 3). Safranin O displays very similar electrochemical and spectroscopical behaviors with those of thionin, to which it is a close relative. From our early study,¹⁹ it was found that safranin O can easily penetrate the phosphatidyl ethanolamine layer, one of the major cell membrane constituents. Surprisingly, virtually no change in absorbance at 518 nm was observed regardless of the presence of glucose, indicating safranin O does not accept electrons. Therefore, we

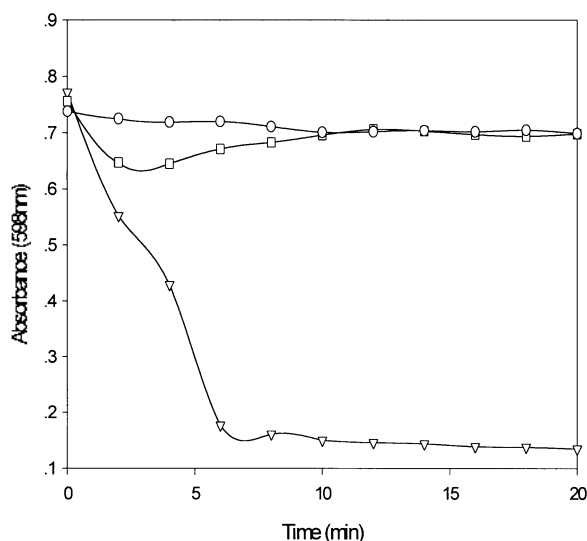

Figure 2. Absorbance change of thionin with time at 598 nm by *P. vulgaris* when 0.01 μmol (\circ), 0.1 μmol (\square), and 1 μmol (\triangle) of glucose was added. Thionin concentration: 0.33 mM; *P. vulgaris*: 10 mg (dry wt)/mL.

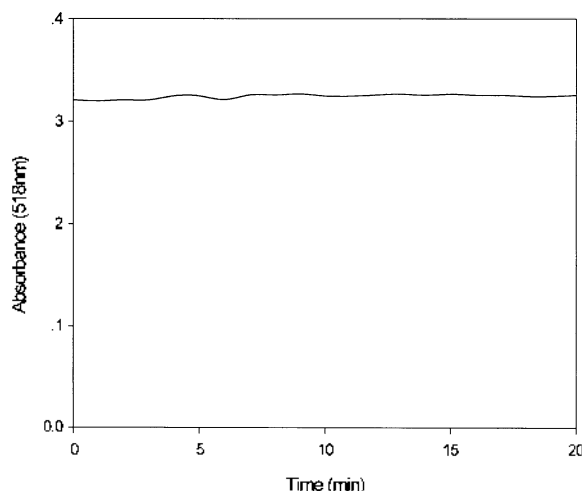

Figure 3. Absorbance change of safranin O with time at 518 nm by *P. vulgaris* when 1 μmol of glucose was added. Safranin O concentration: 0.33 mM; *P. vulgaris*: 10 mg (dry wt)/mL.

used thionin exclusively in this work.

Effect of temperature. Figure 4 shows the polarization curves obtained by changing the external load at several temperatures. Good performance was observed in the range of 30 $^{\circ}\text{C}$ to 42 $^{\circ}\text{C}$ with the highest yield at 37 $^{\circ}\text{C}$, the optimum temperature for *P. vulgaris* growth. At temperatures higher or lower than 37 $^{\circ}\text{C}$, the cell could not pass sufficiently large current. Below *ca.* 1 mA, the cell voltage did not show sensitive change with temperature, but above 1 mA the operation at 37 $^{\circ}\text{C}$ showed much better characteristics. This result is related to the enzymatic activities within *P. vulgaris*. At optimum temperature, enzymes display maximum activities, leading to the highest metabolic rate. Therefore, thionin reduction proceeds at the maximum rate.

Effect of thionin concentration. Figure 5 shows the

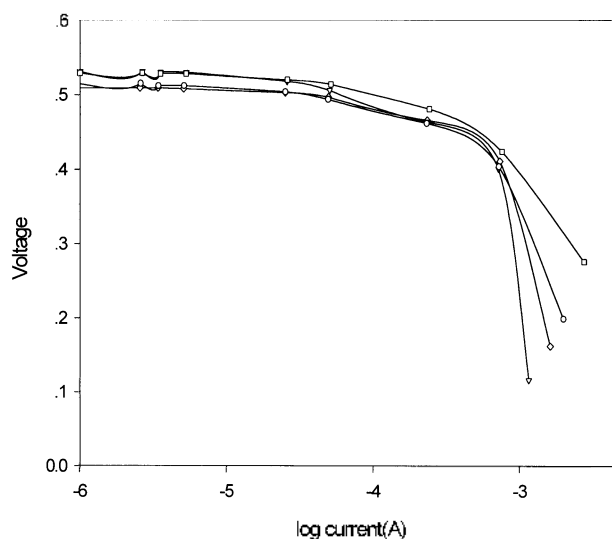

Figure 4. Polarization curves for the fuel cell containing *P. vulgaris*, thionine, and glucose at 25 $^{\circ}\text{C}$ (\circ), 30 $^{\circ}\text{C}$ (\triangle), 37 $^{\circ}\text{C}$ (\square), and 42 $^{\circ}\text{C}$ (\diamond). 100 μmol glucose was initially added. *P. vulgaris*: 0.5 mg (dry wt)/m; thionin concentration: 0.1 mM.

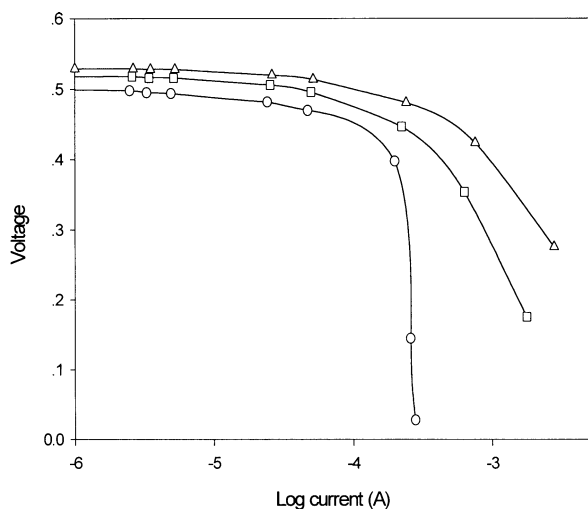

Figure 5. Polarization curves at three different thionin concentrations: 0.01 mM (○); 0.1 mM (△), and 1 mM (□). Other conditions are same as Figure 4.

effect of thionin concentration on the polarization curve. Below 0.01 mM, the cell potential rapidly decreased when large current flowed. This indicates that electrons are not transferred to the anode from *P. vulgaris* at a high rate because of the limited amount of reduced thionin. In the mean time, better characteristics were observed at 0.1 mM thionin concentration. However, contrary to our expectation, the cell showed lower performance at 1 mM. This probably means that the unreduced thionin molecules hinder the rapid electron transfer from being adsorbed on the electrode surface or on the cell membrane.

Current output as a function of time at two different thionin concentrations is shown in Figure 6. After 3 hours, the fuel cell containing 0.5 mM thionin showed an abrupt drop. If 10 μ mol of glucose are consumed, about 23 C is available. However, the resulting charge is far below this value, being

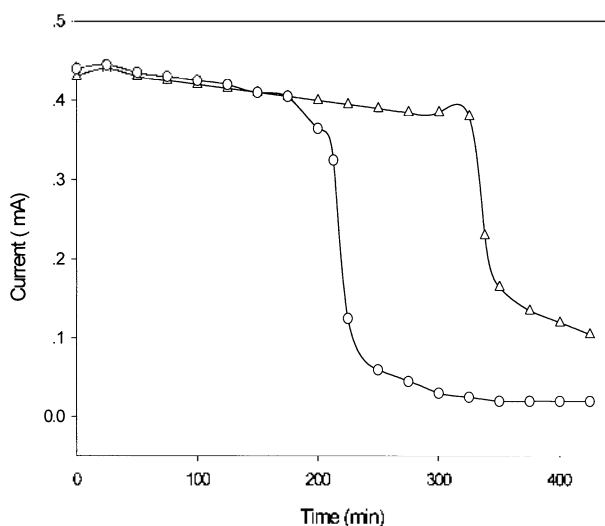

Figure 6. Effect of thionin concentration on current output with time when discharged through the 1 k Ω external load: 0.1 mM (△); 0.5 mM (○). *P. vulgaris*: 10^8 - 10^9 cells/mL. 10 μ mol glucose was initially added.

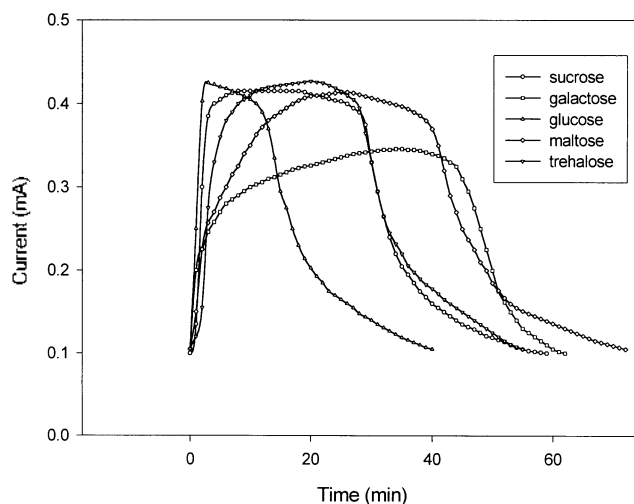

Figure 7. Variation of current output with time for fuel cells containing different carbon sources. *P. vulgaris* was grown on an initially glucose containing medium. *P. vulgaris*: 2×10^8 - 10^9 cells/mL. External load: 1 k Ω .

consistent with the results in Figure 4. At 0.1 mM, a current was maintained for 5 hrs without an appreciable decrease. These results show that the fuel cell performance is closely related to the concentration of a mediator, although the optimum concentration is not certain. The reason for the lower performance at 0.5 mM than at 0.1 mM could be due to the accumulation of thionin on the cell surface of *P. vulgaris*, where the effective electron transfer is hindered.

Charging and discharging characteristics depending on carbon sources. The fuel cell characteristics when glucose, galactose, sucrose, maltose, and trehalose were used is shown in Figure 7. Upon addition after completely discharging the cell, all the carbohydrates except galactose showed about 0.4 mA output. The charging rate was fastest with glucose, but the current decreased after 20 min, showing only 29% coulombic efficiency. In the mean time, the cell showed much improved fuel cell efficiency of 56% when galactose was used although charging was slow and the cell voltage was not fully recovered. This could be attributed to the initial culture condition. Since we grew *P. vulgaris* in a badge containing glucose, all the metabolic states were already adapted to glucose. Therefore, *P. vulgaris* swiftly oxidized glucose, resulting in high charging rate. In the case of galactose, however, the galactose must be converted to galactose-1-phosphate in order to be decomposed by the cellular glycolytic pathway, and then further to glucose-1-phosphate by the number of enzymes. This accounts for the longer time for galactose to be utilized. The reason for the low efficiency of glucose is that electrons are not effectively transferred to thionin although glucose is efficiently oxidized by *P. vulgaris*. The longer duration of current with galactose means thionin accepts more electrons.

Since more enzymes and more metabolic steps are involved for disaccharides to be decomposed, charging is generally slow and the coulombic efficiency is lower than that of galactose. Sucrose, maltose, and trehalose have 27%,

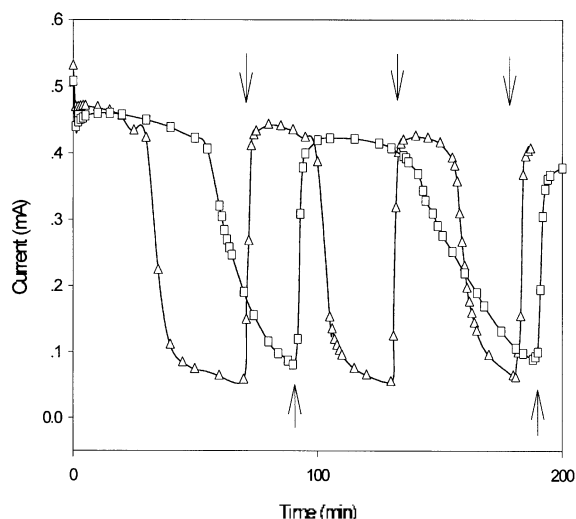

Figure 8. Charging-discharging curves when 1 μmol of glucose (\blacktriangle) and sucrose (\blacksquare) were added through the 1 $\text{k}\Omega$ external load. Injection was marked by arrows. *P. vulgaris*: 10^8 - 10^9 cells/mL.

32%, and 26% efficiencies, respectively.

Figure 8 shows the repetitive charging and discharging curves when glucose and sucrose were used. Current was rapidly recovered to the initial value upon addition of these carbon sources after the output current fell below the background level. This means *P. vulgaris* maintained its reducing power. Sucrose duration time was roughly twice that of glucose, which can be explained by the fact that sucrose has two monosaccharide units. Performance, however, gradually declined under repeated operation. For longer operation of the cell, a new *P. vulgaris* suspension may have to be injected or the optimum operation conditions should be met.

Conclusions

In this paper, we developed a prototype microbial fuel cell using *P. vulgaris* and tested its performance under various conditions. *P. vulgaris*, thionin and various mono- and disaccharides were placed in an anodic compartment, and our cell was able to produce electricity. The cathodic compartment consisted of platinum and ferricyanide and was separated by a Nafion membrane from the anode. Thionin was found to be an effective redox mediator, being reduced by *P. vulgaris*. The fuel cell performance was maximum at 37 $^{\circ}\text{C}$, the optimum temperature for *P. vulgaris*, and dependent on the mediator concentration. Among the tested carbon sources, glucose showed the highest charging rate but a coulombic efficiency of only 29%. Galactose, in the mean time, showed 56% efficiency. This indicates that the efficiency is closely related to the initial culture conditions of *P. vulgaris* as carbon sources are decomposed *via* the glycolytic pathway.

From the repetitive charging and discharging experiments, glucose and sucrose showed better characteristics, but the other carbon sources did not.

There is much room for improvement in the performance of microbial fuel cells. For example, higher electrolyte concentration and operation temperature would give larger current output. Also crucial to the development of microbial fuel cells is the elucidation of the interaction between a mediator and phospholipids.

Acknowledgment. We are greatly indebted to the Korea Research Foundation (Grant No. 1997-012-D00041) for the financial support made for this work in the program year of 1997.

References

1. Kinoshita, K. *Electrochemical Oxygen Technology*; Wiley: New York, 1992.
2. Iwasita, T. *Advances in Electrochemical Science and Engineering*; Tobias, C., Gerischer, H., Eds.; VCH: Weinheim, 1990, Vol. 1.
3. Kordesch, K.; Simander, G. *Fuel Cells and Their Applications*; VCI: Weinheim, 1996.
4. *Proceedings of the Workshop in the Electrocatalysis of Fuel Cell Reactions*; O'Grady, W. E., Srinivasan, S., Dudley, R. F., Eds.; The Electrochemical Society, Inc.: Pennington, NJ, 1979.
5. Yeager, E. B. *J. of Mol. Catal.* **1986**, *38*, 5.
6. Yeager, E. B. *Electrochim. Acta* **1984**, *29*, 1527.
7. Van Veen, J. A. R.; Colyn, H. A.; Van Vaar, J. F. *Electrochim. Acta* **1988**, *33*, 801.
8. *Solid State Electrochemistry*; Bruce, P. G., Ed.; Cambridge University Press: Cambridge, 1995.
9. *Solid Oxide Fuel Cell*; Singhal, S. C., Ed.; The Electrochemical Society, Inc.: Pennington, NJ, 1989.
10. Iacovangelo, C. D. *J. Electrochem. Soc.* **1986**, *133*, 410.
11. Akiba, T.; Benneto, H. P.; Stirling, J. L.; Tanaka, K. *Biotechnol. Lett.* **1987**, *9*, 611.
12. Yagishita, T.; Horigome, T.; Tanaka, K. *J. Chem. Tech. Biotechnol.* **1993**, *56*, 393.
13. Tanaka, K.; Kashiwagi, N.; Ogawa, R. *J. Chem. Tech. Biotechnol.* **1988**, *42*, 235.
14. Karube, I.; Matsunaga, T.; Tsuru, S.; Suzuki, S. *Biotechnol. Bioeng.* **1977**, *19*, 1727.
15. Benneto, H. P.; Dew, M. E.; Stirling, L.; Tanaka, K. *Chemistry and Industry* **1981**, *7*, 776.
16. Benneto, H. P.; Stirling, J. L. *Chemistry and Industry* **1985**, *21*, 695.
17. Habermann, W.; Pommer, E.-H. *Appl. Microbiol. Biotechnol.* **1991**, *35*, 128.
18. *Biosensors: Fundamentals and Applications*; Turner, A. P. F., Karube, I., Wilson, G. S., Eds.; Oxford University Press: Oxford, 1987.
19. Kim, S.; Jung, S. *Bull. Korean Chem. Soc.* **1997**, *18*, 1318.