

# A Study of HC Reduction with Hydrocarbon Adsorber Systems

Geon Seog SON\*, Seung Won YUN, Dae Jung KIM, Kwi Young LEE

*Institute for Advanced Engineering*

**Bung Chul Choi**

*Chonnam National University*

Hydrocarbon adsorber is considered as a promising technology to reduce cold start HCs in automotive exhaust gas. In this study, three in-line adsorber systems were tried to reduce the cold start emission. To check the basic characteristics of adsorber converters, surface areas, TPD and TPA were examined after a hydrothermal aging. Also idle engine bench was used to find the adsorption and desorption capabilities of the adsorber systems at cold start. Finally a practicability of the adsorber systems for the LEV achievement was checked with FTP test on a 2.0 D M/T vehicle. The results of this study indicate that hydrocarbon adsorber system is one of the promising passive technologies to meet the ULEV regulation.

**Key Words** : HC Adsorber, Cold Start Emission, ULEV, Adsorption, Desorption

## Nomenclature

BET	: Brunauer, Emmett, Teller	TPD	: Temperature Programmed Desorption
CARB	: California Air Resources Board	TWC	: Three Way Catalyst
CCC	: Close-Coupled Catalyst		
cpsi	: Cell per square inch		
DOHC	: Double Over Head Cam		
EGR	: Exhaust Gas Recirculation		
EHC	: Electrically Heated Catalyst		
FID	: Flame Ionized Detector		
FTP	: Federal Test Procedure		
GC	: Gas Chromatography		
L	: liter in volume		
LEV	: Low Emission Vehicle		
M/T	: Manual Transmission		
MY	: Model Year		
min	: minute in time		
PM	: Precious Metal		
UCC	: Underbody Catalyst Converter		
ULEV	: Ultra Low Emission Vehicle		
SOHC	: Single Over Head Cam		
TPA	: Temperature Programmed Adsorption		

## 1. Introduction

Emission standards for conventional gasoline cars are mainly aiming at a stringent reduction of their HC emissions. To meet these stringent standards, the cold start emission must be treated effectively. Even though TWC is a state-of-the-art technology that can reduce more than 90% of the engine out emissions of HC, CO and NO<sub>x</sub>, the current TWC cannot convert the emissions before its light off. Therefore the exhaust emissions before the light off of TWC is more than 80% of the total emissions especially in case of HC. To reduce the cold start HC emission, a lot of studies have been carried out using active or passive systems. Among the active systems, Son (1996) reported EHC system and Choi (1998) reported CCC as a passive system to reduce light off time of TWC.

Among the other concepts, HC adsorber systems have been introduced to solve this cold emission problem. The concept of the HC adsorber systems is simple; at temperatures where TWC is not able to convert HCs effectively, HC adsor-

\* Corresponding Author,

E-mail : gsson@iae.re.kr

TEL : +82-31-330-7442 ; FAX : +82-31-330-7113

Institute for Advanced Engineering, (Manuscript

Received March 27, 2000; Revised June 19, 2000)

ber systems should adsorb HCs, and in the ideal case the desorption occurs at temperatures exceeding the light off of TWC. Williams (1996), Hert (1996) and Patil (1996) have already introduced several adsorber systems to reduce cold start HC emission, separately. The most challenging work is how to overcome time difference between light off of TWC and desorption of HCs from HC adsorber, because the light off temperature of TWC is usually higher than that of desorption of the HC adsorber.

In this study, three HC adsorber systems were proposed to overcome this temperature discrepancy between light off of TWC and desorption of HC adsorber. Also the combination of TWC function and HC adsorbing function was introduced on the same converter by double coating method. To check basic characteristics of the adsorbers, surface areas and temperature programmed adsorption/desorption were examined after a hydrothermal aging. Also idle engine bench was used to know the adsorption and desorption capabilities of the adsorber systems at cold start. Finally a practicability of the adsorber systems for the LEV program was checked with FTP test on a 2.0 D M/T vehicle.

## 2. Basic Characteristics of HC Adsorber

### 2.1 Theoretical backgrounds

#### 2.1.1 Specific surface area

The Brunauer-Emmett-Teller (1938) method is the most widely used procedure for the determination of the surface area of solid materials and involves the use of the BET Eq. (1).

$$\frac{1}{W((P_o/P)-1)} = \frac{1}{W_m C} + \frac{C-1}{W_m C} \left[ \frac{P}{P_o} \right] \quad (1)$$

in which  $W$  is the weight of gas adsorbed at a relative pressure  $P_o$  and  $W_m$  is the weight of adsorbate constituting a monolayer of surface coverage. The constant  $C$  is related to the energy of adsorption in the first adsorbed layer and consequently its value is an indication of the magnitude of the adsorbent/adsorbate interac-

tions.

The BET Eq. (1) requires a linear plot of  $\frac{1}{W((P_o/P)-1)}$  versus  $P/P_o$  which is restricted to a limited region of the adsorption isotherm, for most solids using nitrogen as the adsorbate, usually in the  $P/P_o$  range of 0.05 to 0.35. This linear region is shifted to lower relative pressures for microporous materials. The standard multipoint BET procedure requires a minimum of three points in the appropriate relative pressure range. The weight of a monolayer of adsorbate  $W_m$  can then be obtained from the slope  $s$  and intercept  $i$  of the BET plot. From Eq. (1):

$$s = \frac{C-1}{W_m C} \quad (2)$$

$$i = \frac{1}{W_m C} \quad (3)$$

Thus, the weight of a monolayer  $W_m$  can be obtained by combining Eq. (2) and (3).

$$W_m = \frac{1}{s+i} \quad (4)$$

The second step in the application of the BET method is the calculation of the surface area. This requires a knowledge of the molecular cross-sectional area  $A_{cs}$  of the adsorbate molecule. The total surface area  $S_t$  of the sample can be expressed as:

$$S_t = \frac{W_m N A_{cs}}{M} \quad (5)$$

where  $N$  is Avogadro's number and  $M$  is the molecular weight of the adsorbate. Nitrogen is the most widely used gas for surface area determinations since it exhibits intermediate values for the constant  $C$  (5~250) on most solid surfaces, precluding either localized adsorption or behavior as a two dimensional gas. Since it has been established that the constant  $C$  influences the value of the cross-sectional area of an adsorbate, the acceptable range of  $C$  for nitrogen makes it possible to calculate its cross-sectional area from its bulk liquid properties. For the hexagonal close-packed nitrogen monolayer at 77 K, the cross-sectional area  $A_{cs}$  for nitrogen is  $16.2 \text{ \AA}^2$ .

The specific surface area  $S$  of the solid can be calculated from the total surface area  $S_t$  and the sample weight  $w$ , according to Eq. (6).

$$S = \frac{S_t}{w} \quad (6)$$

### 2.1.2 HC Adsorption on zeolite

Physical adsorption is caused mainly by van der Waals forces and electrostatic forces between adsorbate molecules and the atoms which compose the adsorbent surface. Thus adsorbents are characterized first by surface properties such as surface area and polarity.

A large specific surface area is preferable for providing large adsorption capacity, but the creation of a large internal surface area in a limited volume inevitably gives rise to large numbers of small sized pores between adsorption surfaces. The size of the micropores determines the accessibility of adsorbate molecules to the internal adsorption surface, so the pore size distribution of micropores is another important property for characterizing adsorptivity of adsorbents.

Surface polarity corresponds to affinity with polar substances such as water or alcohols. Polar adsorbents are thus called hydrophilic and aluminosilicates such as zeolites, porous alumina and silica gel are examples of adsorbents of this type.

Hydrocarbon collection requires a material with the ability to adsorb desired pollutants from engine exhaust. One class of such materials are zeolite molecular sieves. Zeolites have a three dimensional framework arising from an open framework of  $[SiO_4]^{4-}$  and  $[AlO_4]^{5-}$  tetrahedra linked together. The tetrahedra link together leading to the formation of rings and cages (Secondary Building Units, SBU) These SBUs form the three dimensional structure of the zeolite material. The rings forming channels inside the structure are the structurally important features in zeolites, often known as oxygen widows. The structural formula of a zeolite is best expressed for the crystallographic unit cell as:

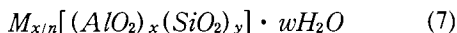

where  $M$  is the cation of valance while  $n$ ,  $w$  is the number of water molecules and the ratio  $y/x$  usually has values of 1~5 depending upon the structure. the sum  $(x+y)$  is the total number of

tetrahedra in the unit cell. The frame work contains channels and interconnected voids which are occupied by the cations and water molecules. The cations are quite mobile and may usually be exchanged, to varying degrees, by other cations. By lowering the alumina content of a zeolite, the tendency to adsorb water is diminishing; the zeolite obtains hydrophobic properties and tends to adsorb non-polar molecules, especially hydrocarbons.

The quantity of gas adsorbed by a zeolite depends upon pressure, temperature, the nature of the gas and the nature of zeolite. Being exposed to a gas, the intracrystalline voids and channels of a dehydrated zeolite are filled with the molecular species concerned and when the filling is complete, no more adsorption occurs. The rate of adsorption decreased as the number of carbon atoms in the hydrocarbon increased; diffusion of the molecule occurred in a stretched-out configuration and the ability of chabazite to adsorb the paraffin hydrocarbon depends on the shape and cross-sectional diameter of the molecules rather than on their molecular volume (Breck, 1973).

## 2.2 Experiments

Table 1 shows the specification of HC adsorbers that was used for basic study. As a reference adsorber, ADS#1 was coated on ceramic substrate with PM and adsorber material using the double coating method to minimize an interaction between PM and adsorber material. In this study large pore and medium pore materials are chosen and mixed together to get good adsorption capacity at both low and high temperatures (Engler, 1993). To check PM effects on conversion performance, PM was removed from ADS#1 and it was

**Table 1** Sample specifications for basic characteristic studies of HC adsorber

Sample ID	Adsorber Material	PM Coating	Substrate
ADS#1	A	○ (Pd/Rh)	400cps, ceramic
ADS#2	A	×	↑
ADS#3	B	○ (Pd/Rh)	↑

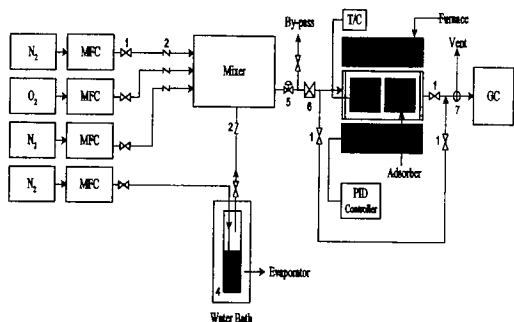

Fig. 1 Schematic diagram of the TPA/TPD apparatus

named as ADS#2. To check adsorber material effects, Si/Al ratio was changed from ADS#1 and it was named as ADS#3.

The three samples were aged for 2 cycles with IAE aging mode that is proposed by Son (1997). The aging mode contains a hydrothermal aging condition at 900°C temperature. The maximum temperature is hold for 4 hours per cycle.

To check the basic performance of the adsorbers, TPA/TPD was done with a GC and a micro electric reactor. Figure 1 shows the schematic diagram of the test apparatus. The adsorbers were cut in 20 mm diameter × 30 mm length and placed in a stainless steel tube (inner diameter=20 mm). And then it was purged with 99.999% N<sub>2</sub> gas for 1 hour at 350 °C. The TPA test was done during 1 °C/min temperature increasing from ambient temperature to 300 °C. The temperature was controlled by a micro electric furnace that has a PID controller. During this temperature increase, an adsorbate gas, decane was supplied with/without O<sub>2</sub> gas. The concentration of decane was 1000 ppm and mass flow controller controlled it. When the O<sub>2</sub> gas was supplied, the O<sub>2</sub> concentration was adjusted to 950 ppm. The balance gas was N<sub>2</sub> and flow rate was 1 L/min. The concentration of the adsorbate gas was measured with a GC (HP5890 Series II) before and after the reactor. The detector was FID. The column was DB1 and the carrier gas was He. The oven temperature and the injector temperature were 200 °C.

The specific surface area was measured with bulk state sample with BET (ATI, Autosorb-1). The sample was evacuated by 10<sup>-6</sup> torr at 300 °C

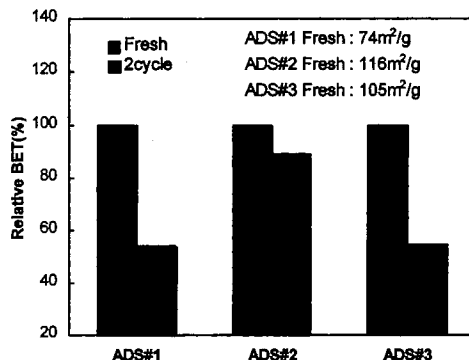

Fig. 2 Relative specific surface areas of fresh and aged adsorbers

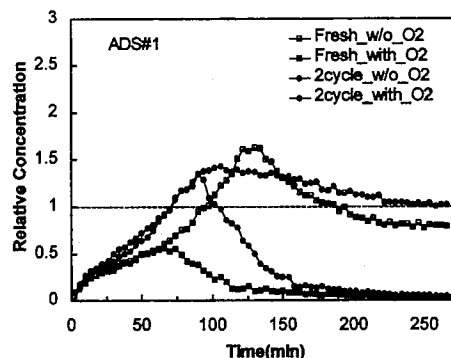

Fig. 3 TPA/TPD results of ADS#1

for 6 hours for a pre-treatment step.

### 2.3 Test results and discussions

Figure 2 shows the relative surface areas of the adsorbers. The relative surface area is the ratio of specific surface area of a sample to that of a fresh sample. The value of fresh sample is indicated in Fig. 2. ADS#2 shows good resistance to hydrothermal aging condition. The other samples that have PM on adsorber show 50% loss of surface area. This means that PM coating with adsorber material can reduce the surface area of adsorber material by an interaction between PM and adsorber material. And this phenomenon is promoted by hydrothermal aging.

Figure 3 shows TPA test results of ADS#1. The vertical axis means the relative concentration of HC. The relative concentration is the ratio of outlet concentration to inlet concentration. The value under “1” indicates HCs adsorption on

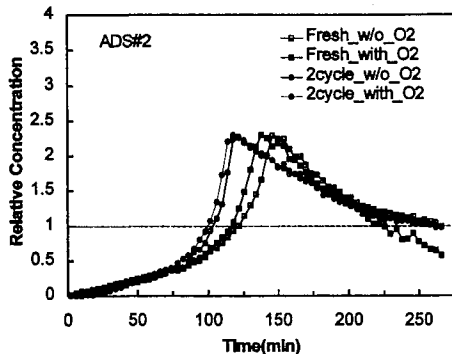

Fig. 4 TPA/TPD results of ADS#2

adsorber, while the value over “1” indicates HCs desorption from adsorber. According to 2 cycle hydrothermal aging, adsorption amount is reduced and desorption time is advanced. However the adsorption amount is not affected by O<sub>2</sub> existence at both states. According to O<sub>2</sub> gas supply, the conversion is occurring by oxidation of HCs with O<sub>2</sub> on activated PM. In case of the fresh state, there is no desorption due to the perfect HCs conversion. This conversion effects is reducing as the converter is aged. This may be explained by the interaction of PM and adsorber material as mentioned at Fig. 2.

Figure 4 shows TPA test results of ADS#2. According to hydrothermal aging, the desorption time is advanced and the adsorption amount is reduced. In case of O<sub>2</sub> supply, the desorption time is advanced but the desorption amount is not affected. Because ADS#2 has no PM, there is no reduction of HCs. The adsorbed HCs are seen at elevated temperature as a desorption. In comparison with Fig. 3 and Fig. 4, it can be seen that the PM on the adsorber plays negative role in point of adsorption amount and start time of desorption. It agrees well with the results of BET. However, after the light off of PM in the O<sub>2</sub> existence, the PM plays a big role in reducing HCs.

Figure 5 shows TPA test results of ADS#3. Adsorption and desorption trends are similar to ADS#1 of Fig. 3. In comparison with Fig. 3 and Fig. 5, it can be seen that adsorber material “A” is better than material “B” in point of adsorption, desorption and hydrothermal resistance. It means

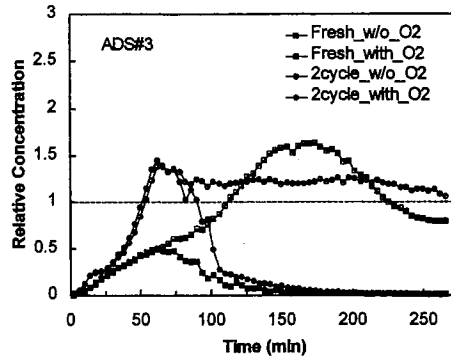

Fig. 5 TPA/TPD results of ADS#3

that material “A” has a good Si/Al ratio ( $y/x$  in Eq. (7)) and combination of large and medium pore structures. Material “B” is severely disturbed the framework structure and the positions of metal cations by hydrothermal aging, so that the structure partially collapsed.

### 3. Application for Vehicle Equipment

#### 3.1 Idle engine bench test

##### 3.1.1 Experiment

The adsorbers of Table 1 was coated on 0.9 L, 400 cpsi oval ceramic honeycomb and then canned with a TWC that is also coated on 0.9 L, 400 cpsi oval ceramic honeycomb. To check the performance of the proposed adsorber systems, three adsorber systems were built as follows. The first adsorber system; the adsorber was holed at the center by 30 mm diameter. There is no back-pressure at the hole compared with adsorber cells. If there is no diverter at the hole, the most exhaust gas flows through the hole. Therefore a diverting air system was equipped at the front of the hole to diverse the exhaust gas before the light off of the CCC. After the light off of the CCC, the diverting air was cut off. It may help the light off of the post TWC and the delay of the desorption of HCs. The diverting air was supplied at 350 L/min for the first 30 seconds. The diverting air was considered not only to diverse the exhaust gas to the adsorber cells but to cool the exhaust gas to delay the start time of the desorption because of temperature dependence of desorption.

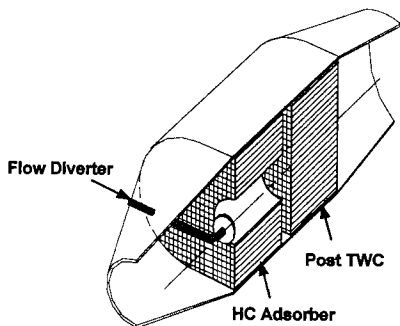

Fig. 6 Schematic diagram of SYS#1 (Diverting air system)

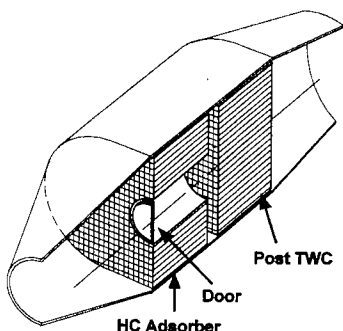

Fig. 7 Schematic diagram of SYS#2 (Diverting door system)

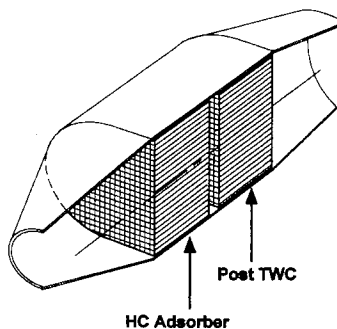

Fig. 8 Schematic diagram of SYS#3 (Passive system)

The second adsorber system; the adsorber was holed at the center by 30 mm diameter. And then door system was equipped instead of diverting air system to prevent the gas flow through the hole before the light off of the CCC. The door system was operated by mechanical driving system controlled by a bimetallic system. The door was closed for the first 30 seconds to divert the exhaust gas to adsorber cells and then opened for the rest time of the test.

The third adsorber system; the adsorber just canned with a TWC. There is no hole and no diverting system. Figures 6~8 show the diagram of three adsorber systems. The adsorber systems were aged on a chassis dynamometer for 6, 400 km at UCC position.

Before the vehicle emission test, idle engine bench test was performed to check the characteristics of adsorption/desorption of the adsorber and the post TWC converter. Table 2 shows the brief specification of the adsorber systems used for idle

Table 2 Sample specifications used for idle engine bench test.

Sample ID	Adsorber				UCC
	Adsorber Material	Hole	Diverter	PM	
SYS#1	A	D30	Air	○	○
SYS#2	A	D30	Door	○	○
SYS#3	A	no	no	○	○
SYS#4	A	D30	Door	×	○
SYS#5	B	D30	Door	○	○

engine bench test.

The idle bench system had a 1.6 DOHC engine (MY 1998) and only the adsorber and it was equipped with an adsorber system of Table 2 for the aftertreatment system. Figure 9 is showing the test apparatus. The ECU was a Korean domestic product. The system was soaked at ambient temperature in soaking room for 9 hours at least. After the crank-in, the emission data analyzed by Horiba MEXA9100 was stored every second for 300 seconds. At the same time the temperatures of coolant, at the center of adsorber and post TWC were also stored. During this data-logging period, there was no acceleration or deceleration. After each test the aftertreatment system was regenerated at above 350 °C for 15 minutes.

### 3.1.2 Test results and discussions

Figure 10 shows the effects of diverting systems. The positive value of vertical axis means the HCs adsorption by adsorber. It seems to be no conversion by PM catalyst, because the center tempera-

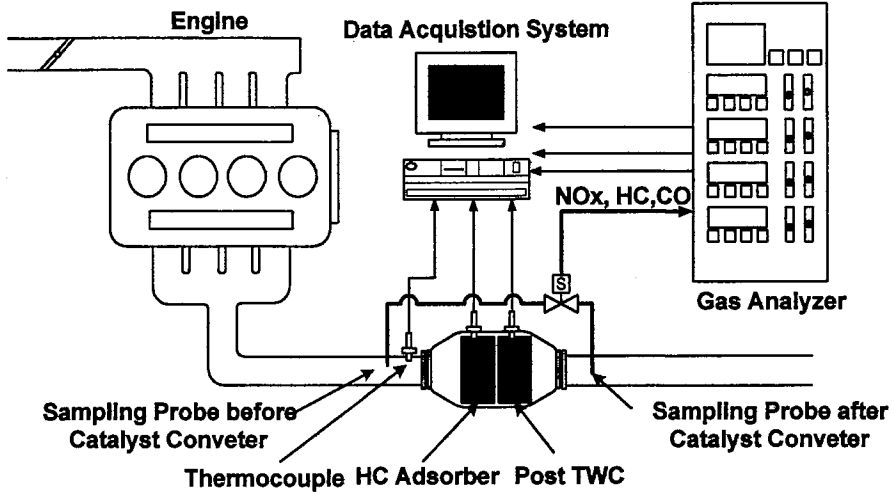

Fig. 9 System diagram of idle engine bench test

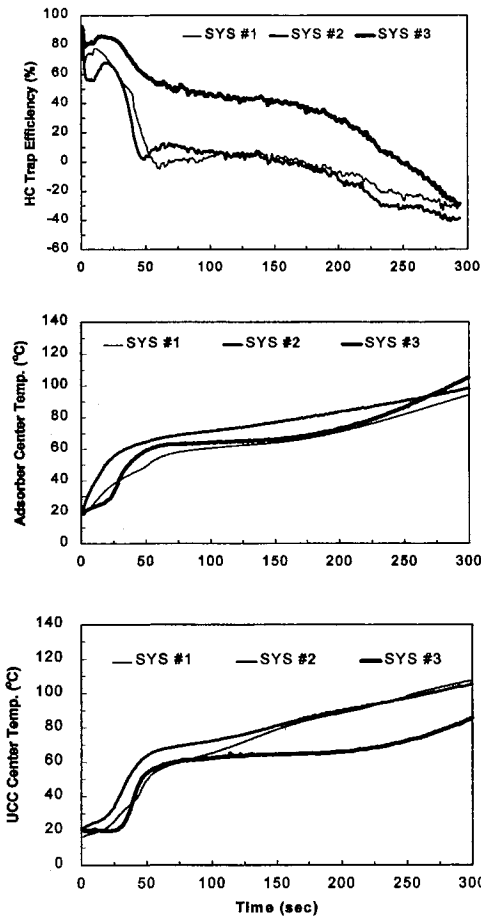

Fig. 10 The Effects of diverting systems on HC trap efficiency, temperature of the center of adsorber and post TWC

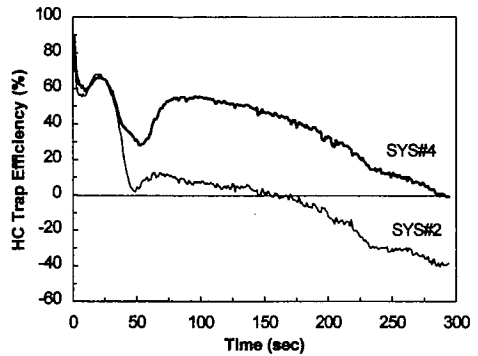

Fig. 11 PM effects on HC trap efficiency

tures of the adsorber and the post TWC do not exceed 150°C during the test. The test has no acceleration as mentioned before. Therefore temperature-increasing rate is much slower than that of vehicle test. SYS#3 shows the best HC trap efficiency. It means that SYS#3 has a good capability to hold the HCs for a long time. The middle figure shows the center temperature of the adsorbers. As it can be expected SYS#1 shows the lowest temperature due to supply of diverting air that roles cooling the exhaust gas. The bottom figure shows the center temperature of the post TWC. Because there is no hole in SYS#3, SYS#3 shows the lowest temperature at the center of the post TWC after the first 30 seconds. SYS#1 also shows the lowest temperature during the first 30 seconds.

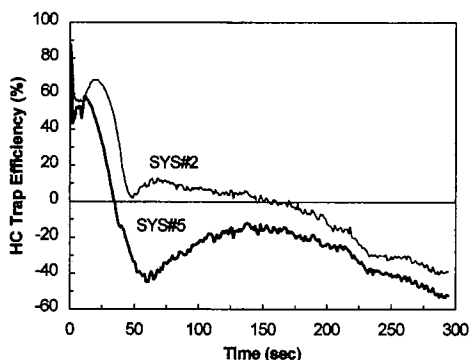

Fig. 12 Adsorber material effects on HC trap efficiency

Figure 11 shows the effects of PM catalyst on adsorber. In case of SYS#4 that has no PM, it shows a good adsorption capability compare with SYS#2. It means that the addition of PM to adsorber can disturb the active site of adsorber material and can reduce the adsorbent site on adsorber. This result corresponds well with that of Fig. 2 and Fig. 4.

Figure 12 shows the effects of the adsorber materials on adsorber. Adsorber material “A” shows better performance on adsorption and desorption. Therefore the material “A” is adopted for vehicle tests.

### 3.2 Pre-test on vehicle

#### 3.2.1 Experiment

After idle engine bench test, the three adsorber systems (SYS#1, #2, #3) and a high loaded CCC +UCC system were tested on a chassis dynamometer with FTP75 mode. The aftertreatment system was composed of a CCC, an adsorber and a post TWC. The CCC has only TWC function. The adsorber and the post TWC were canned together and they were located at UCC position. The vehicle (MY 1998) had a 2.0 DOHC engine, manual transmission and an EGR. The ECU level was for the LEV regulation. Table 3 shows the brief specifications of aftertreatment systems used for vehicle tests. The CCC used for vehicle tests were aged on an engine bench for 50 hours. The engine used for bench aging was a 3.0 L V6 SOHC. One aging cycle is

Table 3 Sample specifications of aftertreatment systems used for pre-test on vehicle.

Test ID	CCC Position	UCC Position
TEST#1	10.6g/L, 0.67L, 1/28/1*, 50hrs Bench aging	8.8g/L, 1.8L, 10/0/1*, 6.4k Filed aging
TEST#2	2.7g/L, 0.67L, 0/1/0*, 50hrs Bench aging	SYS#1, 1.8L, 6.4k Field aging
TEST#3	↑	SYS#2, 1.8L, 6.4k Field aging
TEST#4	↑	SYS#3, 1.8L, 6.4k Field aging

\* Pt/Pd/Rh Ratio

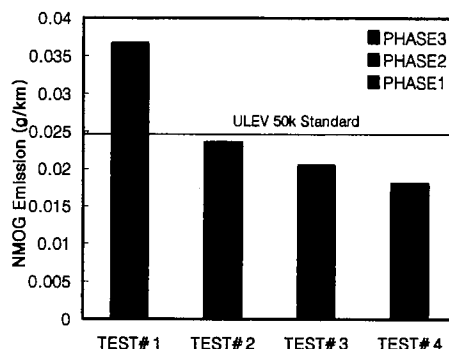

Fig. 13 Test results of pre-test on vehicle

for 60 seconds and it has a fuel enrich mode and an air injection mode for 16 seconds. During the aging cycle the maximum bed temperature was 1000 °C. All adsorber systems and post TWC were aged on a chassis dynamometer for 6,400 km.

#### 3.2.1 Pre-test results and discussions

Figure 13 shows the vehicle test results according to the combinations of CCC and the adsorber systems as noticed at Table 3. The data mean the average NMOG value of 3 times of FTP75 test. All adsorber systems (TEST#2, #3, #4) show better performance than the conventional CCC +UCC system (TEST#1) even though the PM loading of CCC is much lower than that of the conventional CCC +UCC system. The PM loading of TEST#1 is designed for the LEV regulation. The emission of phase 1 also shows the same



**Table 4** Aftertreatment specifications for vehicle test of adsorber systems.

Sample ID	CCC Position	UCC Position
#1	Original LEV System 50k Bench aging	Original LEV System 50k Bench aging
#2	↑	SYS#3, 1. 8L, 50k Bench aging
#3	↑	SYS#3 with Adsorber Material "B", 1.8L, 50k Bench aging
#4	1/2 Loading of #1, 2, 3 50k Bench aging	SYS#3, 1. 8L, 50k Bench aging

trend. It means that adsorber system plays an important role in reducing the cold start HC emission. In the comparison among the adsorber systems, TEST#4 (SYS#3) shows the best results. SYS#3 has no any diverting systems. However the active diverting systems like as TEST#2 (SYS#1) and TEST#3 (SYS#2) show higher emission. The active systems need a control system and an actuator. Also they need additional energy compared with passive system. In this study SYS #1 has the most complicate diverting systems and need the highest energy. And SYS#2 follows SYS #1. Therefore for the application of adsorber systems to vehicle, a passive system like SYS#3 seems to be good in point of economy and performance.

### 3.3 Vehicle test

#### 3.3.1 Experiment

To find a practicability of adsorber system for ULEV regulation, vehicle tests have done with aged aftertreatment systems. The vehicle used in this test was the same with that of the pre-test. For UCC, SYS#3 was chosen according to the result of pre-test. For CCC, low loading catalyst was chosen to consider cost. The CCC and UCC were aged on an engine bench to simulate 80, 000 km field aging. To compare the performance with the original LEV aftertreatment system certified by CARB, the original system was aged with the same aging method. Table 4 shows the specifications of aftertreatment systems used in vehicle

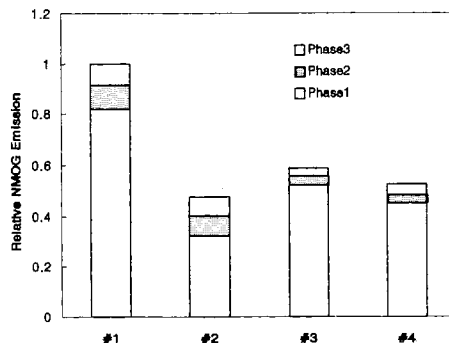
**Fig. 14** Results of FTP75 vehicle tests

tests.

#### 3.3.2 Results and discussions

Figure 14 shows the results of vehicle tests. Compare to LEV system (#1), all adsorber systems (#2 ~#4) reduced NMOG emissions by more than 40%. This means that HC adsorber system can be effectively used for reduction of cold start emission. In the comparison of #2 and #3, adsorber material "A" showed good performance and this result correspond well with that of engine bench test. In the comparison of #2 and #4, high loading CCC showed slightly good performance. In the comparison of #3 and #4, even though CCC of #4 had much lower PM loading, #4 showed good performance. It means that adsorber in UCC can compensate lower PM loading of CCC. ULEV NMOG regulation is 53% of LEV and #2 and #4 systems showed 47%, 52% of the original system that satisfied LEV regulation. Therefore #2 and #4 system can meet ULEV regulation without any change of vehicle system like as ECU, EGR, exhaust pipe, etc as well as without addition of active system like as EHC and secondary air injection. Because the price of adsorber material is much cheaper than that of PM, cost of #4 system satisfying ULEV regulation can be lower than that of LEV aftertreatment system.

## 4. Conclusions

HC adsorber systems were studied to reduce cold start HC emission. Basic characteristics of 2 kinds of adsorber materials were examined with

TPA and BET. For the vehicle application three adsorber systems were built and they were tested on an idle engine bench to analyze the adsorption and desorption trends. Finally using the three adsorber systems, vehicle emission tests were conducted on 2.0 DOHC M/T vehicle. One was passive and the others were active in line adsorber systems. The active systems have a diverting door system or a diverting air system. The aftertreatment systems have a CCC, and an adsorber and a TWC at UCC position.

1) Adsorber material and PM can have a negative interaction when they are on the same converter brick, even though they were coated by double coating technology.

2) After hydrothermal aging, the adsorption amount is reduced and the desorption time is advanced.

3) When oxygen exists in exhaust gas, the PM plays a positive role to reduce the adsorbed HCs by oxidation reaction, even though they were aged in hydrothermal environments. This oxidation seems to reduce the cold start HC emission.

4) Compared with the conventional CCC + UCC system, all adsorber systems considered in this study are good for reduction of the cold start HC emission.

5) The passive in-line adsorber system shows better performance than two active in-line adsorber systems that need a control and an actuator system.

6) Even though all adsorber systems are the promising technology for the cold start HC emission, the passive system has a practicability in

point of economy and performance.

## References

- Breck, D. W., 1973, *Zeolite Molecular Sieves*, John Wiley & Sons, New York, pp. 5~18.
- Brunauer, S., et al., 1938, *J. Amer. Chem. Soc.*, Vol. 60, p. 309.
- Choi, B. C., Kim, D. J., Son, G. S. and Lee, K. Y., 1998, "Estimation of CCC (Close Coupled Catalyst) System for Low Emission Vehicles," *Journal of Japan Society of Automotive Engineers*, Vol. 29, pp. 25~30.
- Engler, B. H., Lindner, D., Lox, E. S., Ostgathe, K. and Muller, W., 1993, "Reduction of Exhaust Gas Emissions by Using Hydrocarbon Adsorber Systems," *SAE* 930738.
- Herti, W., Patil, M. D., and Williams, J. L., 1996, "Hydrocarbon Adsorber System for Cold Start Emissions," *SAE* 960347.
- Patil, M. D., Hertl, W., Williams, J. L. and Nagel, J. N., 1996, "In-Line Hydrocarbon Adsorber System for ULEV," *SAE* 960348.
- Son, G. S., Choi, B.C. and Lee, K.Y., 1996, "Electrically Heated Catalyst (EHC) System for Low Emission Vehicle," *ASME, ICE*-Vol. 26-1, pp. 9~18.
- Son, G. S., Lee, G. Y., Lee, K. Y., and Choi, B. C., 1997, "Study I of Catalyst aging," *Journal of Korea Society of Automotive Engineers*, 5, pp86~94.
- Williams, J. L., Patil, H.D. and Hertl, w., 1994, "By-Pass Hydrocarbon Adsorber System for ULEV," *SAE* 960343.