

# Fatigue Damage of Quasi-Isotropic Composite Laminates Under Tensile Loading in Different Directions

In-Kweon Kim\*, Chang-Duk Kong

Department of Aerospace Eng., Chosun University

Kyung-Seop Han

Pohang University of Science and Technology

The purpose of this work is to investigate fatigue damage of quasi-isotropic laminates under tensile loading in different directions. Low cycle fatigue tests of  $[0/-60/60]_s$  laminates and  $[30/-30/90]_s$  laminates were carried out. Material systems used are AS4/Epoxy and AS4/PEEK. The fatigue damage of  $[30/-30/90]_s$  is very different from that of  $[0/-60/60]_s$ . The experimental results are compared with the result obtained from the method for determining strain energy release rate components proposed by the authors. The analytical results were in good agreement with the experimental results. It is proved that the failure criterion based on the strain energy release rate is an appropriate approach to predict the initiation and growth of delaminations under cyclic loading.

**Key Words :** Quasi-Isotropic Composite Laminates, Fatigue Damage, Strain Energy Release Rate(SERR), Tensile Loading

## 1. Introduction

Composite laminates which is commonly used in the aerospace are generated delamination due to stress singularity near the free-edge, which was linked with final stiffness lower. Thus, these phenomena happen not only in cyclic loading but also in fatigue loading in static stiffness.

It may be considered that quasi-isotropic laminates have isotropic elastic properties in all in-plane directions. Therefore, this kind of laminate is widely used for structural elements. The objective of this paper is to investigate the effects of the directions of applied load and to examine the fatigue damage mechanisms of the quasi-isotropic laminates of AS4/Epoxy and AS4/PEEK as shown Fig. 1. The free-edge delaminations are

caused by the interlaminar stresses which is generated in the vicinity of the free edge, and this delamination mechanism can be used as structures in experiments and in practice(Pipes and Pagano, 1970; O'Brien, 1982). The experimental results are compared with the results obtained from the method in determining strain energy release rate(SERR) components proposed by the authors' previous study (Kim, 1998; Kim et al., 1996).

## 2. Analysis

It is considered which is quasi-isotropic laminate of applied uniaxial extension,  $N_x$ , whose stacking sequence is  $[0/-60/60]_s$  when the direction of applied axial load to the  $[0/-60/60]_s$  laminate is inclined to an 30-degree angle, because the  $[30/-30/90]_s$  laminates is confronted with a problem of the applied axial load,  $N_x$ . We calculated the SERR for free-edge delaminations to two problems and the SERR for mode component of free-edge delaminations using a simple method to two problems. It was shown in

\* Corresponding Author,

E-mail : inkkim@mail.chosun.ac.kr

TEL : +82-62-230-7186 ; FAX : +82-62-232-9218

Department of Aerospace Engineering, Chosun University, 375, Seosuk-dong, Dong-gu, Kwangju 501-759, Korea. (Manuscript Received March 12, 1999; Revised February 25, 2000)

Fig. 2 that the SERR of  $[30/-30/90]_s$  laminate. The calculation was performed with composite materials properties AS4/938(CF/Epoxy) (Kim, 1998; Kim et al., 1996).

In order to find the mode component of SERR for the delaminations value that grow delamination value at each interfaces, the SERR is normalized by the square of the applied axial strain,  $\epsilon_0 = 0.001$ . The  $[30/-30/90]_s$  laminate has the possi-

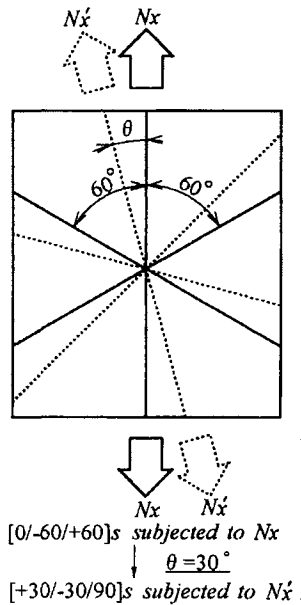

Fig. 1 Variation of tensile loading direction

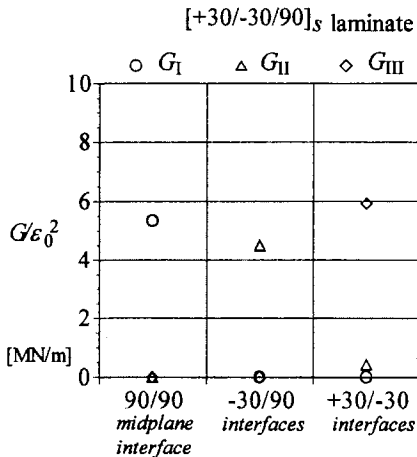

Fig. 2 Strain energy release rates for  $[30/-30/90]_s$  laminate with free-edge delaminations at each interfaces

bility that the edge delamination grows at each interface. At the  $30/-30$  interfaces, mode-III delamination will grow, and the probability of growth is mainly concerned with the critical value of  $G_{IIIcr}$ . At the  $-30/90$  interfaces, mixed mode delaminations will be formed as well, and the probability of growth is primarily related to the critical value of  $G_{IIcr}$ . At the midplane  $90/90$  interface, opening mode delamination will occur when the SERR exceeds the critical value of  $G_{Icr}$ . Therefore, The SERR of the  $[0/-60/60]_s$  laminate has  $G_I = G_{II} = 0$ ,  $G_{III}/\epsilon_0^2 = 0.0147$  MN/m at  $-60/60$  interfaces.

### 3. Tensile Fatigue Testing

#### 3.1 Specimen

The experiment by using static tensile specimen and tensile fatigue test of quasi-isotropic composite laminate are shown as the species and constitution in Table 1.

Where E is Epoxy, P is PEEK, Q is quasi-isotropic, 01 is the  $[0/-60/60]_s$  laminate, and 02 is  $[30/-30/90]_s$  laminate. The geometry and size

Table 1 Family of specimen

Specimen	Stacking Sequence	Composite Materials
EQ01	$[0/-60/60]_s$	AS4/Epoxy
EQ02	$[30/-30/90]_s$	AS4/Epoxy
PQ01	$[0/-60/60]_s$	AS4/PEEK
PQ02	$[30/-30/90]_s$	AS4/PEEK

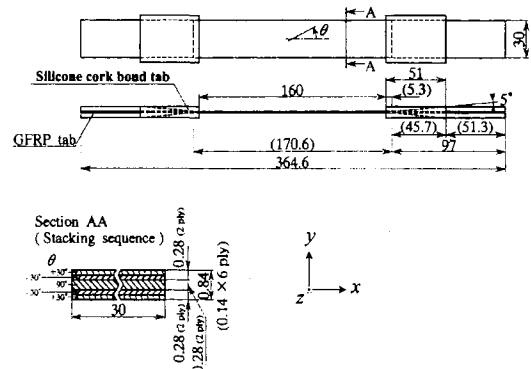
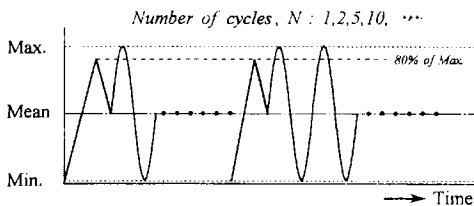

Fig. 3 Configuration of specimen

of specimen is shown in Fig. 3. As the specimen use the GFRP tab, tab joining was appropriated with FM-123. In the case of fatigue the vicinity of tab is caused by the interlaminar stresses which arise failure and delamination. In order to reduce them, the prevention as near by tab is covered with the low stiffness-material, the stress concentration can be relaxed in vicinity of the tab according to analysis result, which set in taper angle of 5-degree and the tab tip cover with silicone cork bond.

**3.2 Testing method**

It was conducted that quasi-static stiffness was applied with about 60% load in load-controlled tensile fatigue tests. As shown in Fig. 4, the cyclic loading was applied with specified intervals and 80% of the monotonic cyclic load to the specimen to measure static stiffness. Acetate tape replicas was used to observe fatigue damage through the thickness and to reduce average stress on the free edge. Also, the applying cyclic load has 5Hz during measuring AE and reduced load until



**Fig. 4** Wave form of cycle loading

minimum stress. The above measurement was executed at each 1, 2, 5, 10... $\times 10^6$  cycles. The stopped operation does not add to cyclic loading which the maximum stress is applied loading. AE measured by the 50-times after cyclic number. This experiment measured strain by strain gauges and an extensometer. The extensometer of Instron Co. was use, where gauge length was 12.5mm and maximum displacement quantity was  $\pm 2.5$ mm. Fatigue damage process was observed with replicas on the free edge.

**3.3 Experimental results and considerations**

The loading direction of quasi-isotropic composite laminate or in the case of the different matrix, fatigue damage process examined shows some differences. To begin with, as the observation result of interlaminar delamination failure surface by the replica method, the next, the recorded strain in PC, load, experiment results depicted from the acquired AE data.

The  $[60/-60/60]_s$  AS4/epoxy laminate and the  $[0/-60/60]_s$  AS4/PEEK laminate did not have any visible fatigue damage from free-edge replica up to final failure. As shown in Photo. 1, in the  $[30/-30/90]_s$  AS4/epoxy laminate in of the replica photograph delamination was observed after several 1000-cycles in 90-angle plies. Thereafter, during cyclic frequency increment, delamination propagated to the onset, and transverse crack grew.

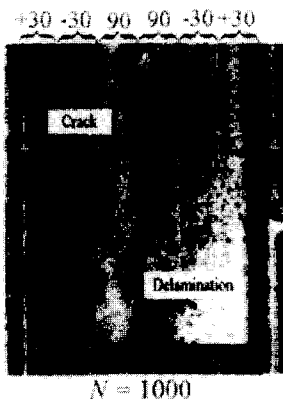

**Photo. 1** Replica of free-edge delaminations of  $[30/-30/90]_s$  AS4/Epoxy laminate

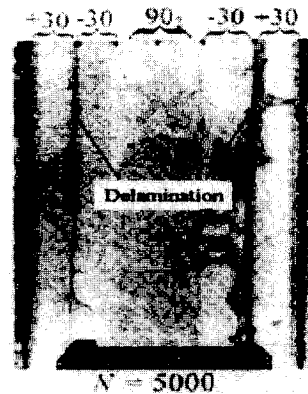

**Photo. 2** Replica of free-edge delaminations of  $[30/-30/90]_s$  AS4/PEEK laminate

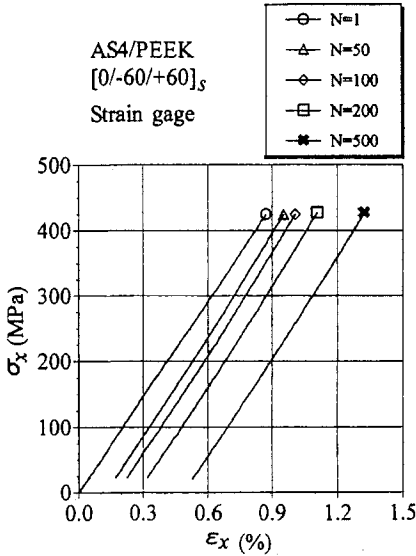

Fig. 5 Stress-strain curve of  $[0/-60/60]_s$  AS4/PEEK laminate

As shown in Photo. 2, the  $[30/-30/90]_s$  AS4/PEEK laminate in the replica photograph had delamination after 5000-cycles at 30/-30 interfaces, and delamination was propagated with cyclic frequency increment.

The next, it is shown that experiment results were the acquired data of strain, load, AE *etc.* where,  $N$  value of photograph is cyclic frequency of fatigue experiment. Therefore, the strain gauge is expressed by the acquired strain gauge value, and the extensometer is expressed by the acquired value with extensometer.

The stress-strain curve which is acquired from tensile fatigue test of  $[0/-60/60]_s$  AS4/PEEK laminate is shown in Fig. 5. As shown in Fig. 5, for the  $[0/-60/60]_s$  AS4/PEEK laminate the slope of the stress-strain curve did not change as the cyclic frequency of fatigue experiment  $N$  is increased. The stiffness degradation of laminate which is acquired from stress-strain curve is shown in Fig. 6.

Most stiffness did not degrade until final failure in  $[0/-60/60]_s$  laminate or did not observe fatigue damage in the replica.  $[0/-60/60]_s$  AS4/epoxy laminate did not remarkably generate the stiffness degradation and did not observe the fatigue damage. The damage to reach failure did

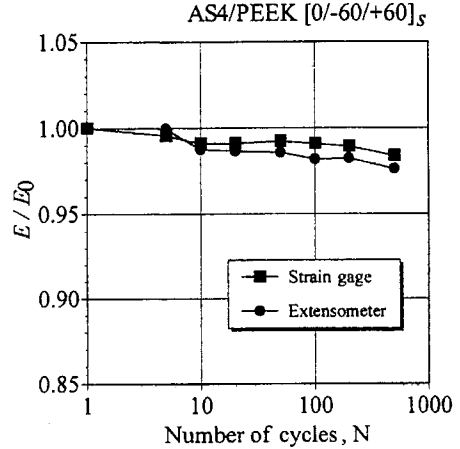

Fig. 6 Stiffness loss of  $[0/-60/60]_s$  AS4/PEEK laminate

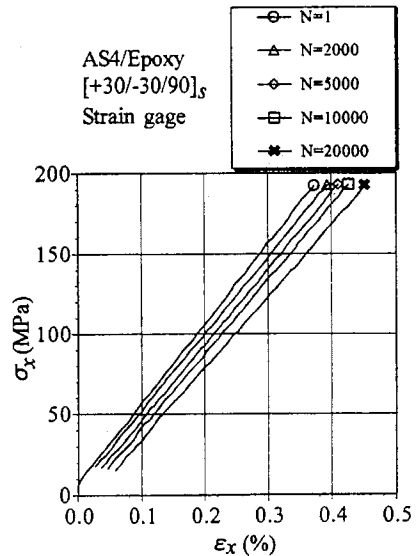

Fig. 7 Stress-strain curve of  $[30/-30/90]_s$  AS4/epoxy laminate

not observe macroscope observation method and consider that micro-interface can be generated between fiber and matrix. The stress-strain curve from fatigue test of  $[30/-30/90]_s$  AS4/epoxy laminate showed in Fig. 7. As shown in Fig. 7, for the  $[30/-30/90]_s$  AS4/epoxy laminate the slope of the stress-strain curve changed remarkable while the cyclic frequency of fatigue experiment  $N$  is increased.

As seen in Fig. 8, the cyclic frequency in some

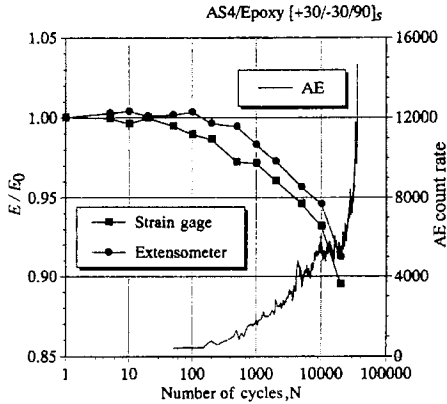

Fig. 8 Stiffness loss and AE count rate of [30/-30/90]<sub>s</sub> AS4/epoxy laminate

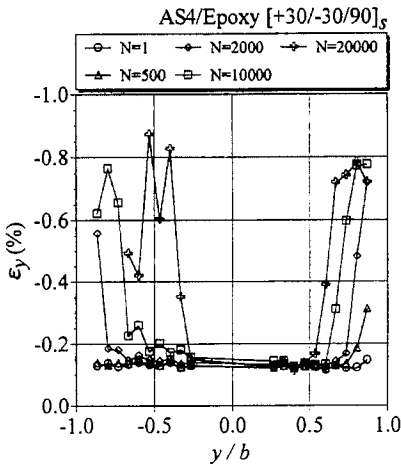

Fig. 9 Distribution of  $\epsilon_y$  along width in [30/-30/90]<sub>s</sub> AS4/epoxy laminate

100-cycle increase AE generation ratio and know the stiffness lower. Because this cause can observe delamination in 90-degree at the replica photograph under  $N=100$  also, we consider that delamination to be generated in 90-degree is propagated by the fatigue damage.

Figure 9 has plotted laminate width along with  $y$ -axis width direction strain,  $\epsilon_y$ , of the specimen surface. We saw that the distribution of  $\epsilon_y$  has been increased cyclic frequency together. These causes propagated delamination be generated in the free-edge, because in the free-edge region, top-side bending strain grows larger. The stress-strain curve which is acquired from tensile fatigue test of [30/-30/90]<sub>s</sub> AS4/PEEK laminate

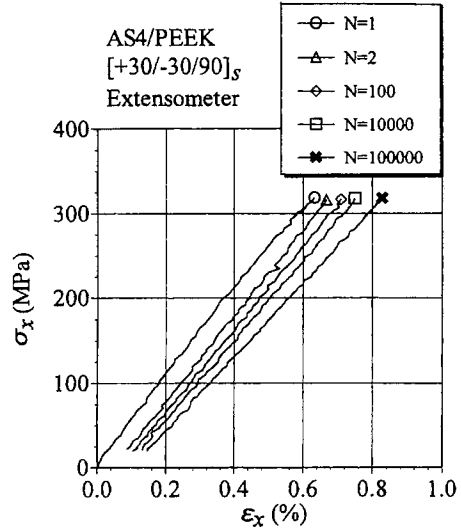

Fig. 10 Stress-strain curve of [30/-30/90]<sub>s</sub> AS4/PEEK laminate

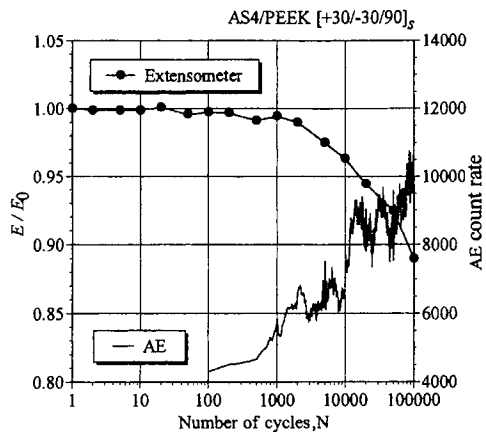

Fig. 11 Stiffness loss and AE count rate of [30/-30/90]<sub>s</sub> AS4/PEEK laminate

showed in Fig. 10.

As seen in Fig. 10, we have been remarkably shown inclination change. The stiffness degradation state of the laminate is shown in Fig. 11.

As seen in Fig. 11, cyclic frequency in some 1000-cycle increase AE generation ratio and know the stiffness lower. Thus, as shown in Photo. 2, because these can be observed delamination in 30/-30 interfaces at the replica photograph under  $N=100$  also, we consider that delamination to be generated in 30/-30 interfaces is propagated by the fatigue damage.

#### 4. The Analysis and Experimental Result Comparison

We will compare with and examine the SERR analysis result of the free-edge delamination acquired from the tensile fatigue and the simple method. Also, when free-edge delamination observed delamination-generation strain,  $\varepsilon_{cr}$ , from the acquired simple method, applied to the mode component analysis result of the SERR, and quantitatively estimated the free-edge delamination and growth of composite laminate. The delamination mode component of the SERR which generated in the  $[0/-60/60]_s$  laminate of the free-edge is  $G_I = G_{II} = 0$ ,  $G_{III}/\varepsilon_0^2 = 0.0147\text{MN/m}$  at  $-60/60$  interfaces, besides all interfaces are  $G = 0$ . The probability which delamination hardly generated can predict and the analysis result explains well the experimental result.

As seen from replica photograph of Photo. 1 ( $N=100$ ), in the case of  $[30/-30/90]_s$  AS4/epoxy laminate can observe the generation of delamination 90-degree plies at the interface. Because the mode component of the SERR of laminate midplane (90/90) in Fig. 2 is  $G_I = G_{II} = 0$ , the value of  $G_I$  only exists. Thus, this delamination can explain the onset and growth of mode-I delamination.

As seen from replica photograph of Photo. 2 ( $N=1000$ ), in the case of  $[30/-30/90]_s$  AS4/PEEK laminate can observe the generation of delamination 30/-30 plies at the interfaces. We see that the mode component of the SERR of laminate 30/-30 interfaces in Fig. 2 is higher the value of  $G_I$ ,  $G_{II}$  than the value of  $G_{III}$ .

Thus, this delamination can explain the onset and growth of mode-III delamination. By these results, The delamination analysis result of mode component of the SERR which is generated in the composite laminate explain experimental result and consider the probability of delamination prediction at interface.

Both epoxy and PEEK in  $[0/-60/60]_s$  did not observe delamination-generation. However, the stacking sequence  $[30/-30/90]_s$  laminate, tensile loading direction changed, generated delamina-

tion and observed the different fatigue damage. Delamination-generation position differed from matrix different in the same stacking sequence.  $[30/-30/90]_s$  AS4/epoxy laminate of the midplane (90/90 at interface) plies are  $G_I/\varepsilon_0^2 = 5.33\text{MN/m}$ , 30/-30 at interfaces are  $G_{III}/\varepsilon_0^2 = 5.92\text{MN/m}$ . Among these, delamination in the interface of some way is raised to generate possibility. It consider that this laminate related to  $G_{IIIcr}$  at 30/-30 interfaces generated delamination. Thus, as shown in Reference (Armanios et al., 1989; Wang et al., 1995; Corleto et al., 1989; Prel et al., 1989) Table, delamination-generation position differed from matrix difference in the same stacking sequence, thus, both epoxy and PEEK due to the value of the critical SERR difference was considered.

#### 5. Conclusions

The onset and growth of the free-edge delamination from the experimental result of applied cyclic loading, quasi-isotropic composite laminate and the simple method of the mode component of the SERR was possible in the qualitative and quantitative estimation.

The  $[0/-60/60]_s$  AS4/epoxy laminate and the  $[0/-60/60]_s$  AS4/PEEK laminate did not show any fatigue damage during cyclic loading or did not generate the free-edge delamination. The  $[30/-30/90]_s$  AS4/epoxy laminate from replica photograph can observe the generation of delamination 90-degree plies at the interface. This delamination from the mode component of the SERR can explain the onset and growth of mode-I delamination. The  $[30/-30/90]_s$  AS4/PEEK laminate from the replica photograph can observe the generation of delamination 30/-30 plies at the interfaces. This delamination from the mode component of the SERR can explain the onset and growth of mode-III delamination. Finally, simple method from the value of the SERR, by using the delamination-generation strain,  $\varepsilon_{cr}$ , acquired by experiment, the critical strain energy release  $G_{cr}$  preassumption was possible. Thus, the free-edge delamination from the quasi-isotropic composite laminate and the simple method of the

mode component of the SERR can be explained in qualitatively and quantitatively.

Quasi-isotropic composite laminates under tensile loading in different directions dissimilar the fatigue damage and the position of delamination generated at AS4/epoxy and AS4/PEEK laminate are different from the matrix difference. Because these consider the value of both  $G_{Icr}$  and  $G_{IIIcr}$  difference.

### Acknowledgement

This study was supported by BK (Brain Korea) 21 of ministry of education.

### References

- Armanios, E. A., Rehfield, L. W., Raju, I. S. and O'Brien, T. K., 1989, "Sublaminar Analysis of Interlaminar Fracture in Composite: Part II - Applications," *Journal of Composites Technology & Research, Winter*, p. 147.
- Corleto, C. R., and Bradley, W. L., 1989, "Mode II Delamination Fracture Toughness of Unidirectional Graphite/Epoxy Composites," *Composite Materials, Fatigue and Fracture, Second Volume*, ASTM STP 1012, p. 201.
- Kim, I. K., et al., 1996, "Fatigue Test of Quasi-Isotropic Composite Laminates Under Tensile Loading in Different Directions," *Proc. of the JSASS/JSME Structures Conf.*, Vol. 38, p. 201. (in Japanese)
- Kim, I. K., 1998, "A Simple Method to Calculate Mode Components of Strain Energy Release Rate of Free-Edge Delaminations in Composite Laminates," *KSME International Journal*, Vol. 12, No. 4, p. 672.
- O'Brien, T. K., 1982, "Characterization of Delamination Onset and Growth in a Composite Laminates," *Damage in Composite Materials*, ASTM STP 775, p. 140.
- Pipes, R. B and Pagano, N. J., 1970, "Interlaminar Stresses in Composite Laminates Under Uniform Axial Extension," *Journal of Composite Materials*, 4, p. 538.
- Prel, Y. J., Davies, P., Benzeggagh, M. L., and de Charentenay, F. X., 1989, "Mode I and Mode II Delamination of Thermosetting and Thermoplastic Composites," *Composite Materials, Fatigue and Fracture, Second Volume*, ASTM STP 1012, p. 251.
- Wang, H., Khanh, T. V., and Le, V. N., 1995, "Effects of Large Deflection on Mode II Fracture Test of Composite Materials," *Journal of Composite Materials*, Vol. 29, No. 6, p. 829.