

Effect of Temperature on the Fracture Toughness of A516 Gr70 Steel

Chang-Sung Seok*
(Sungkyunkwan University)

Fracture toughness JIC and KIC tests were performed on A516 Gr70 carbon steel plate at the temperature ranging from -160°C to 600°C , and test results were analyzed according to ASTM E 813 and ASTM E 399. Unloading compliance J-integral tests were performed on 1TCT specimens. The relation between the J_{IC} value and the test temperature was obtained. It was concluded that the temperature ranging from -15°C to 600°C is the upper shelf region of ductile-brittle transition temperature, and in this temperature range, fracture toughness J_{IC} values decreased with increasing temperature. The ductile brittle transition temperature of the material may be around -30°C . In the region near -30°C , the tendency of J_{IC} to decrease with decreasing temperature was significant.

Key Words : J-Integral, Fracture Toughness, Temperature Effect, DBTT

1. Introduction

Elastic-plastic fracture toughness, J_{IC} can be used as an effective design criterion in nuclear and thermal steam rising systems. Most of these systems are operated at high temperature and J_{IC} values are affected by temperature. (Mills, 1987 ; Jung and Murty, 1988) Therefore, the J_{IC} values at high temperature must be determined for the use of integrity evaluation and designing of such systems.

The ductile brittle transition temperature (DBTT) has long been used in the design of steel construction. The material must be chosen so that its transition temperature is low enough in comparison with the minimum service temperature, the difference being a function of the degree of safety which is tolerated. Therefore, the DBTT must be determined for designing of mechanical constructions. (Francois, 1986) With the advance-

ment of the J-integral (Rice, 1968) elastic plastic fracture mechanics, it has become possible to develop transition temperature data in terms of the J_{IC} fracture toughness parameter which defines the upper shelf toughness as well as the lower shelf and transitional toughness values. (Joyce and Hasson, 1980)

The objective of this paper is to investigate the effect of temperature on the elastic-plastic fracture toughness J_{IC} and K_{IC} in A516 Gr70 steel. The fracture tests were performed at temperature ranging from -160°C to 600°C according to ASTM E 399(1996) and ASTM E 813(1996).

2. Fracture Toughness Test

2.1 Specimens

The A516 Gr70 carbon steel plate supplied in the normalized condition has been used extensively in nuclear vessel applications. The chemical composition and mechanical properties are shown in Table 1 and Table 2, respectively.

Figures 1 and 2 show the dimensions and orientation of the test specimens. All specimens configurations were ASTM standard compact tension (CT) type, with the pin hole of 0.25 W and 0.1875 W where 'W' is the specimen width.

* Corresponding Author,

E-mail : csseok@yurim.skku.ac.kr

TEL : +82-331-290-7477 ; FAX : +82-331-290-7482
Dept. of Mechanical Engineering, Sungkyunkwan University, 300 Chunchun-dong, Jangan-gu, Suwon Kyonggi-do 440-746, Korea. (Manuscript Received February 27, 1999 ; Revised October 7, 1999)

Table 1 Chemical composition of A516 Gr70 (wt %)

C	Si	Mn	P	S	Mo	Al	Ni	V
0.21	0.24	1.07	0.013	0.004	0.06	0.035	0.20	0.38

Table 2 Mechanical properties of A516 Gr70

Temperature (°C)	Tensile Strength (MPa)	Yield Strength (MPa)	Elongation(%)
-30	628	451	18
-15	618	422	20
0	618	412	19
10	598	402	20
20	569	383	22
100	559	373	26
200	549	373	29
300	540	363	31
400	579	363	27
500	520	304	34
600	441	265	37

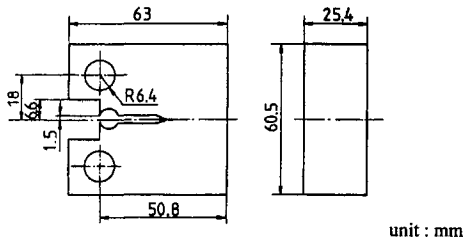

(a) Specimen for COD gage

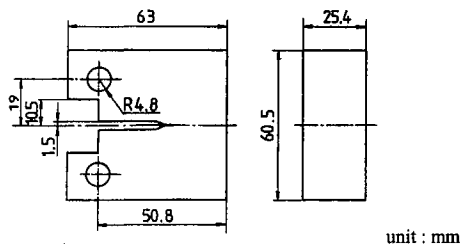

(b) Specimen for high temperature extensometer

Fig. 1 Dimension of CT specimen

Specimens were notched to an initial a/W ratio of 0.5 and precracked to a crack length of approximately $a/W=0.6$ where 'a' is the crack length.

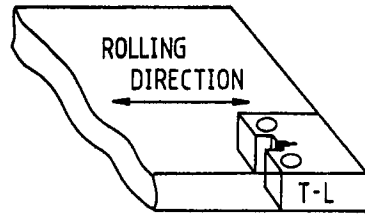
**Fig. 2** Orientation of specimen

2.2 Test procedure

Fracture toughness tests were performed following ASTM E813 test procedure at temperatures ranging from -160°C to 600°C which covers the ductile-to-brittle transition as well as upper shelf regimes. Load line displacements were measured by a COD gage (Instron Ltd. Catalog No. 2670-116) for a temperature range of $-160^{\circ}\text{C} \leq T \leq 100^{\circ}\text{C}$ and by a high temperature extensometer (Instron Ltd. Catalog No. 2632-001) for $20^{\circ}\text{C} \leq T \leq 600^{\circ}\text{C}$. Usually, the load line displacement is measured by a high temperature COD gage in an environmental chamber for high temperature J_{IC} test. In this paper, high temperature J_{IC} tests were performed with a high temperature extensometer in a split furnace. Temperature control was achieved by enclosing the specimen in an electrically heated split furnace and mounting a thermocouple nearby the crack tip of the specimen. In all cases, temperatures were controlled to better than $\pm 1^{\circ}\text{C}$ with self-adaptive temperature controllers.

A high temperature extensometer was mounted on the crack mouth at the load line of the specimen as shown in Fig. 3, and held in position by a set of springs. Tests were also performed with the COD gage at 20°C and 100°C . Figure 4 shows the schematic diagram of the high temperature JIC testing system.

To observe the ductile brittle transition temperature behavior, fracture toughness J_{IC} and K_{IC} tests were performed at the temperature range of -160°C to 20°C . The specimen temperature was controlled by liquid nitrogen below the room temperature in an environmental chamber. Figure 5 shows the schematic diagram of the low temperature fracture toughness testing system.

After fatigue precracking at room temperature,

all tests were performed in stroke control on dynamic universal testing machine at test temperature. The test loading was regularly interrupted by 10% unloadings (Smith and Doig, 1986 ; Neal and Priest, 1986) and autographic records of load versus load-line displacement were obtained. At the end of each test, specimens were completely unloaded, heat-tinted at about 300°C for 10 minutes and broken open. The fatigue crack length and final crack extension were measured directly from the fractured surface. All procedures

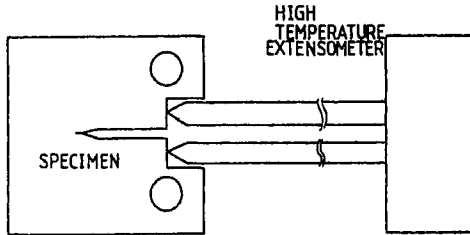

Fig. 3 Measurement of load-line displacement with high temperature extensometer

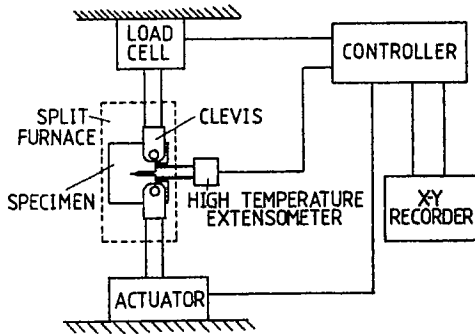

Fig. 4 Schematic diagram of high temperature J_{IC} testing system

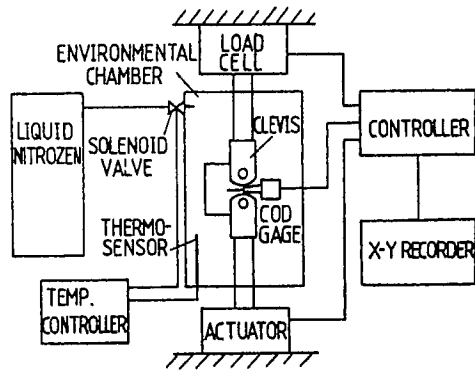

Fig. 5 Schematic diagram of low temperature testing system

of tests and reductions were carried out in accordance with the ASTM E 813 and ASTM E 399.

2.3 Test results

Test results with the high temperature extensometer at temperatures ranging from 20°C to 600°C are as shown in Figs. 6~12. Results with the COD gage at -15°C, 0°C, 20°C and 100°C are as shown in Fig. 13~16. Table 3 shows J_{IC} values and constants C_1 and C_2 of R-curves [$J = C_1(\Delta a)^{C_2}$] obtained from the test.

At temperature ranging from -160°C to -30°C, all specimens fractured in a brittle manners during loading without stable crack extension. In these cases, the areas (A) under the P- δ curves were determined from which the J_q was calculated (ASTM E 813),

$$J_q = \frac{A}{Bb} \left(2 + 0.522 \frac{b}{w} \right) \tag{1}$$

where b is the remaining ligament.

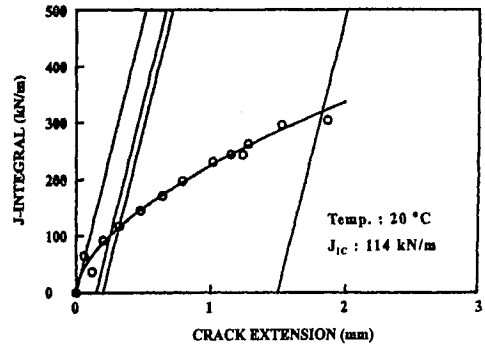

Fig. 6 $J-\Delta a$ curve for A516 Gr70 steel with high temperature extensometer at 20 °C

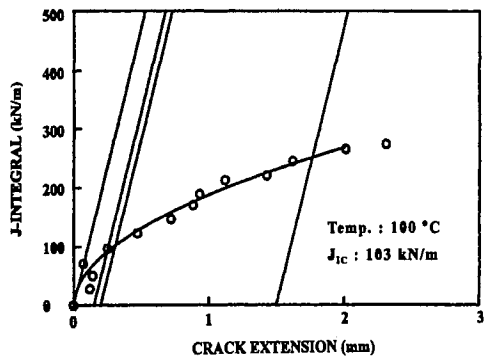

Fig. 7 $J-\Delta a$ curve for A516 Gr70 steel with high temperature extensometer at 100 °C

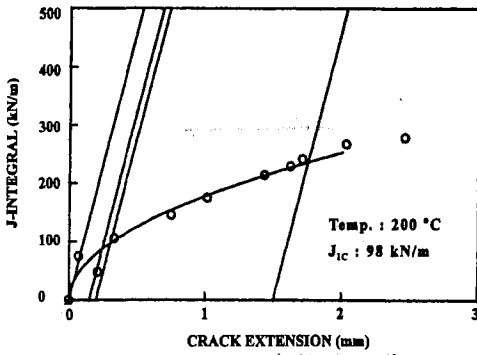

Fig. 8 J- Δa curve for A516 Gr70 steel with high temperature extensometer at 200 °C

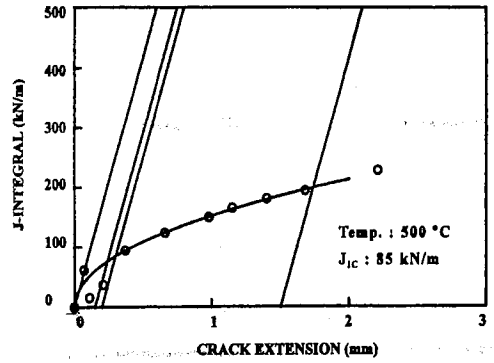

Fig. 11 J- Δa curve for A516 Gr70 Steel with high temperature extensometer at 500 °C

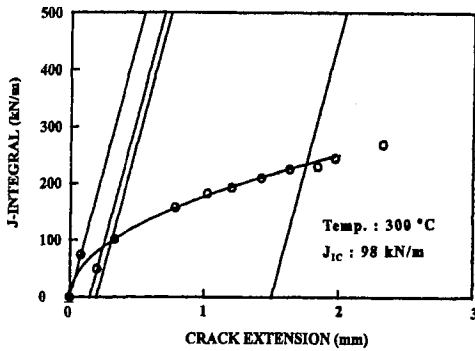

Fig. 9 J- Δa curve for A516 Gr70 steel with high temperature extensometer at 300 °C

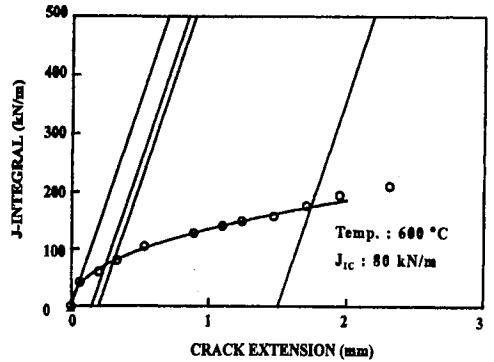

Fig. 12 J- Δa curve for A516 Gr70 steel with high temperature extensometer at 600 °C

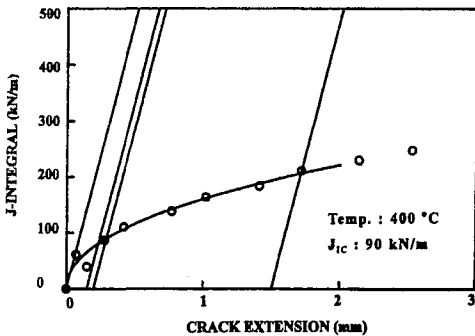

Fig. 10 J- Δa curve for A516 Gr70 steel with high temperature extensometer at 400 °C

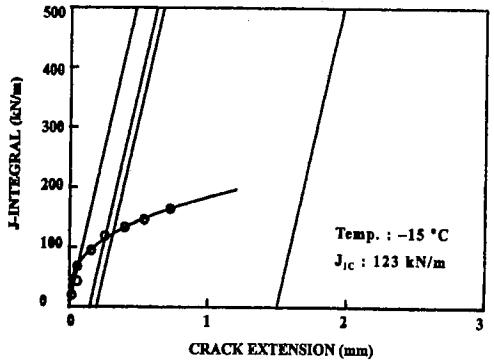

Fig. 13 J- Δa curve for A516 Gr70 steel with COD gage at -15 °C

Results of the fracture toughness parameter J_{IC} versus the temperature are summarized in Table 4.

For the tests at temperatures ranging from -100°C to -30°C, the specimens were broken after some ductile deformation. However, for the -130°C, -140°C, -150°C and -160°C tests, brittle fracture occurred without ductile deforma-

tion at maximum load.

$J(K_Q)$ values were then calculated from K_Q values using the following conversion equation. (Rice, 1968)

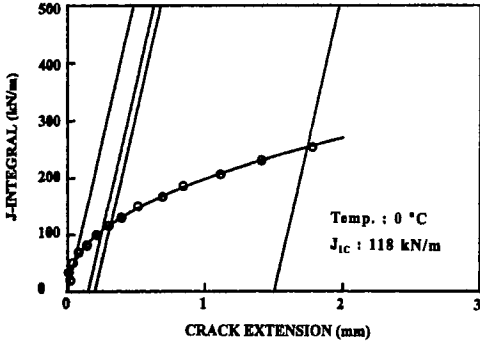

Fig. 14 J-Δa curve for A516 Gr70 steel with COD gage at 0 °C

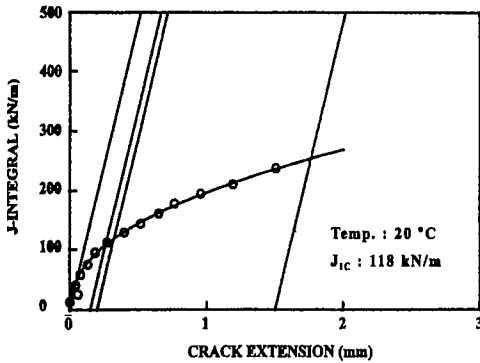

Fig. 15 J-Δa curve for A516 Gr70 steel with COD gage at 20 °C

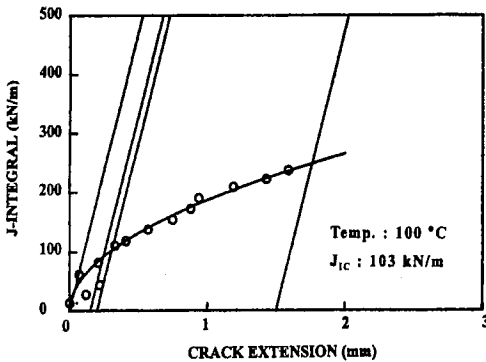

Fig. 16 J-Δa curve for A516 Gr70 steel with COD gage at 100 °C

$$J(K_Q) = \frac{(1-\nu^2)(K_Q)^2}{E} \quad (2)$$

The K_{IC} test results versus temperatures are as summarized in Table 4.

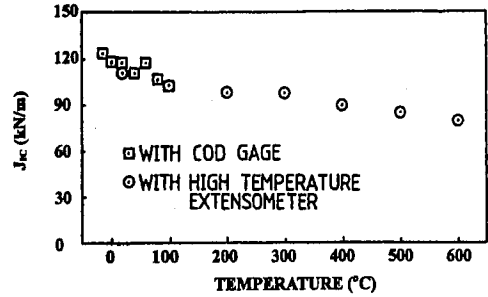

Fig. 17 The effect of temperature on the J_{IC} of the upper shelf region of DBTT

3. Discussion

Experimental results show that the load-line displacement can be measured successfully by the high temperature extensometer. Figs. 6, 15, and also Figs. 7, 16 are the J_{IC} test results for the same temperature of 20°C and 100°C, respectively, but the different load line displacement sensor. That is Figs. 5 and 6 are obtained with the high temperature extensometer while Figs. 15 and 16 with the COD gage. The J_{IC} values and R-curves determined by the high temperature extensometer well agreed with those determined by the COD gage at that temperatures.

Figure 17 shows that the elastic plastic fracture toughness, J_{IC} values at the upper shelf region of ductile-brittle transition temperature (DBTT) decreased with increasing temperature. The J_{IC} value and the test temperature can be correlated as follows:

$$J_{IC} = -0.06 T + 115 \quad (3)$$

where T is the temperature [°C], and J_{IC} is the elastic-plastic fracture toughness[kN/m].

It may be recognized in this study that the temperature ranging from -15°C to 600°C was the upper shelf region of ductile-brittle transition temperature. The constants C_1 and C_2 of R-curve [$J = C_1(\Delta a)^{C_2}$] are shown in Table 3, and J_{IC} values might be affected by the C_1 and C_2 (Ross and Eisele, 1988).

It is noted that C_1 decreases with the test temperature very similar to J_{IC} while C_2 slightly increases initially reaching essentially a constant

Table 3 The effect of temperature on J_{IC}

Test Method	Temperature (°C)	R-Curve [$J = C_1 (\Delta a)^{C_2}$]		
		J_{IC} (kN/m)	C_1	C_2
With COD gage	-15	123	185	0.34
	0	118	199	0.44
	10	121	192	0.40
	20	118	197	0.56
	100	J103	187	0.50
With high temperature extensometer	20	114	224	0.59
	100	103	188	0.51
	200	98	178	0.50
	300	98	178	0.50
	400	90	160	0.47
	500	85	153	0.49
	600	80	135	0.45

Table 4 Test results of J_{IC} and K_{IC}

Temperature (°C)	J_{IC} Test Results		K_{IC} Test Results	
	J_{IC} or J_Q (kN/m)	Validity	K_Q (kN/m ^{3/2})	$J(K_Q)$ (kN/m)
20	118	○	58800	15
10	121	○	60400	16
0	118	○	57600	15
-15	123	×	59800	16
-30	63	×	62300	17
-50	51	×	68600	20
-100	40	×	74000	24
-130	18	×	63900	18
-140	18	×	64200	18
-150	12	×	52800	12
-160	12	×	52500	12

value. None of the three parameters reveals any discernible effect of DSA. However, the load-displacement curves seem to reveal DSA effects. At temperatures of 200°C and 300°C, the maximum load attained on the reloading of the specimen after the small unloading to determine the crack length is higher than that just prior to the unloading as shown in Fig. 18. The phenomenon exhibits serrations in load - displacement curves, and the temperature might be influencing the magnitude of this effect and the J_{IC} values. The strain aging may be suspected, (Miglin et al., 1986) however, no dips in the DSA range were

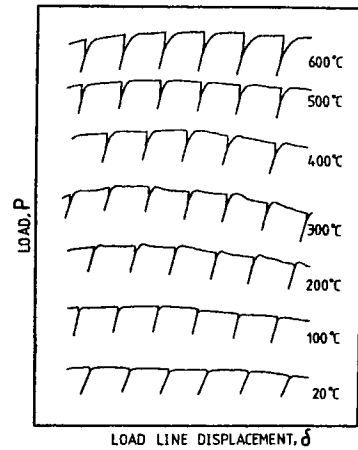
**Fig. 18** P- δ curve for A516 Gr70 steel at several test temperature

noted contrary to the earlier researcher's observations in A533B steel and pure iron. (Jung and Murty, 1988 ; Murty, 1999 ; Murry and Mahmood, 1990)

For 0°C and 20°C tests, stable crack extension was observed as shown in Fig. 14 and Fig. 15, and the J_{IC} values were valid by ASTM standard. For the J_{IC} test result at -15°C as shown in Fig. 13, stable crack extension was not large enough to be valid by ASTM E 813. At low temperatures below -30°C stable crack extension was not long enough to evaluate J_{IC} based on ASTM standard, and J_Q calculated from maximum load revealed transition from brittle to ductile fracture.

In order to meet the ASTM validity requirement for the thickness of K_{IC} specimen, specimen thickness B should be greater than $2.5(K_Q/\sigma_Y)^2$. But in this study, the requirement was not satisfied.

The variation of the elastic-plastic fracture toughness parameter J_{IC} and K_{IC} versus temperature at the range below room temperature is presented in Fig. 19. At temperature range below -15°C, the J_Q values are invalid because the stable crack extension of the specimen was not sufficient, but it is obvious that the values are critical values of J at onset of fracture. So the value may be used as a reference fracture toughness value. The K_{IC} values at the temperature range of -130°C to -160°C are useful in spite of

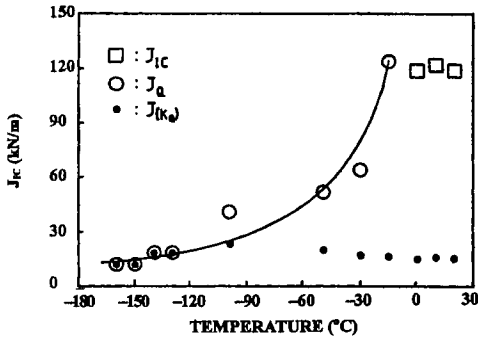

Fig. 19 The effect of temperature on the J_{IC} at the range below room temperature.

the thickness requirement not being satisfied. In this region, brittle fracture occurred without ductile deformation and J_Q values calculated from Eq. (1) agreed well with $J(K_Q)$ values calculated from Eq. (2). However, the K_Q values determined in the other temperature regions cannot be taken as a fracture toughness of the material. In this study, the J_{IC} fracture toughness parameter was used for evaluation of temperature effect.

The ductile brittle transition temperature (DBTT) of A516 Gr70 steel is about -30°C . The ductile-to-brittle transition temperature of -30°C was determined as the temperature corresponding to the average of the upper shelf toughness and the fracture toughness at the temperatures below -130°C . In the transition region near -30°C , the tendency of J_{IC} to decrease with decreasing temperature was significant. The tendency of transition temperature behavior of fracture toughness was similar to the results of others. (Joyce and Hasson, 1980 ; Watainabe et al, 1987)

At temperatures ranging from -160°C to -15°C , the J_Q value and the test temperature can be correlated as follows:

$$J_Q = -\frac{4000}{(T-15)} - 10 \quad (4)$$

where T is the test temperature [$^\circ\text{C}$], and the J_Q is the elastic-plastic fracture toughness value [kJ/m²].

4. Conclusions

The following conclusions were obtained from

the study.

(1) It may be recognized that the temperature ranging from -15°C to 600°C is the upper shelf region of ductile-brittle transition temperature (DBTT). In this temperature range, the elastic plastic fracture toughness J_{IC} values decreased with increasing temperature, however, it was insignificant.

(2) The DBTT of A516 Gr70 steel may be -30°C . In the transition region near -30°C , the tendency of J_{IC} decrease with decreasing temperature was significant.

(3) The load-displacement results during the J-tests show some evidence of strain aging phenomenon at temperatures 200°C and 300°C . However, no dips in the DSA range were noted contrary to the earlier researcher's observations in A533B steel and pure iron.

Acknowledgements

The author is grateful for the support provided by a grant from the Korea Science & Engineering Foundation (KOSEF) and Safety and Structural Integrity Research Center at the Sungkyunkwan University.

References

- Francois, D., 1986, "Relation between Various Fracture Transition Temperature and the K_{IC} Fracture Toughness Transition Curve," *Engineering Fracture Mechanics*, Vol. 23, No. 2, pp. 455 ~ 465.
- Joyce J. A. and Hasson, D. F., 1980, "Characterization of Transition Temperature Behavior of HY 130 steel by the J_{IC} Fracture Toughness Parameter," *Engineering Fracture Mechanics*, Vol. 13, pp. 417~430.
- Jung Y. H. and Murty, K. L., 1988, "Effect of Temperature and Strain Rate on Upper Shelf Fracture Behavior of A533B Class 1 Pressure Vessel Steel," *ASTM STP969*, pp. 392~401.
- Miglin, M. T., Van Der Sluys, W. A., Futato, R. J. and Domian, H. A., 1986, "Effect of Strain Aging in the Unloading Compliance J Test," *ASTM STP 856*, pp. 150~165.

Mills, W. J. 1987, "Fracture Toughness of Two Ni-Fe-Cr Alloys," *Engineering Fracture Mechanics*, Vol. 26, No. 2, pp. 223~228.

Murty, K. L. and Mahmood, S. T., 1990, "Serrated Flow in Irradiated and Partially Denitrided Mild Steel," *ASTM STP 1046*, pp. 422~430.

Murty, K. L., 1999, "Role and Significance of Source Hardening in Radiation Embrittlement of Iron and Ferritic Steels," *Journal of Nuclear Materials* 270, pp. 115~128.

Neal, B. K. and Priest, R. H., 1986, "The Unloading Compliance Method for Crack Length Measurement Using Compact Tension and Pre-cracked Charpy Specimens," *ASTM STP 856*, pp. 375~393.

Rice, J. R., 1968, "A Path Independent Integral and the Approximate Analysis of Strain Concentration by Notches and Cracks," *Journal of Applied Mechanics*, Vol. 35, pp. 379~386.

Ross, E. and Eisele, V. 1988, "Determination

of Material Characteristic Values in Elastic-Plastic Fracture Mechanics by Means of J-Integral Crack Resistance Curve," *Journal of Testing and Evaluation*, Vol. 16, No. 1, pp. 1~11.

Smith, R. F., and Doig, P., 1986, "Crack Length Measurement by Compliance in Fracture Toughness Testing," *Experimental Mechanics*, pp. 122~127.

Watanabe, J., Iwadate, T., Tanaka, Y., and Yokobori, T., 1987, "Fracture Toughness in the Transition Region," *Engineering Fracture Mechanics*, Vol. 28, No. 516, pp. 589~600.

1996, "Standard Test Method for J_{IC} , A Measure of Fracture Toughness," *Annual Book of ASTM Standards*, ASTM E 813-89.

1996, "Standard Method of Test for Plane-Strain Fracture Toughness of Metallic Materials," *Annual Book of ASTM Standards*, ASTM E 399-90.