

Design of a Fuzzy-Sliding Mode Controller for a SCARA Robot to Reduce Chattering

Seok Jo Go[†]

Department of Machine System, Dongeui Institute of Technology

Min Cheol Lee*

School of Mechanical Engineering, Pusan National University

To overcome problems in tracking error related to the unmodeled dynamics in the high speed operation of industrial robots, many researchers have used sliding mode control, which is robust against parameter variations and payload changes. However, these algorithms cannot reduce the inherent chattering which is caused by excessive switching inputs around the sliding surface. This study proposes a fuzzy-sliding mode control algorithm to reduce the chattering of the sliding mode control by fuzzy rules within a pre-determined dead zone. Trajectory tracking simulations and experiments show that chattering can be reduced prominently by the fuzzy-sliding mode control algorithm compared to a sliding mode control with two dead zones, and the proposed control algorithm is robust to changes in payload. The proposed control algorithm is implemented to the SCARA (selected compliance articulated robot assembly) robot using a DSP (digital signal processor) for high speed calculations.

Key Words : Sliding Mode Control, Chattering, Dead Zones, Fuzzy Rules, Fuzzy-Sliding Mode Control, SCARA Robot

1. Introduction

The PID control algorithm has been used for control of most industrial robots. However, this algorithm cannot provide high precision for high speed tasks where abrupt changes in dynamic parameters occur. Unless nonlinearities of robot manipulators are properly compensated for, control performance is not satisfactory with a PID algorithm. Moreover, an accurate model of a robot system is very difficult due to nonlinear friction and changes in the load during task execution (Fu, et al., 1987).

In order to overcome the problems of un-

modeled dynamics involved in high speed operation of industrial robots, many researchers have used sliding mode control, which is robust against parameter variations and payload changes (Dong and Shifan, 1996; Fruta and Tomiyama, 1996; Harashima, et al., 1986; Hashimoto, et al., 1987; Lee and Aoshima, 1993; Slotine, 1985; Young, 1978). Lee and Aoshima (1993) proposed a sliding mode control algorithm in which nonlinear and unmodeled dynamic terms were considered as external disturbances. However, the algorithm could not reduce the inherent chattering which was caused by excessive switching inputs around the sliding surface.

In the previous study, the sliding mode control algorithm with two assumed dead zones was proposed to reduce the chattering. The dead zone was defined in an optional section around the switching line. As the state value converges to the switching line, the switching control input for compensating the disturbance term becomes smaller (Lee and Shin, 1997; Lee, et al., 1998; Lee, et

[†] First Author

* Corresponding Author,

E-mail : mcleee@hyowon.pusan.ac.kr

TEL : +82-51-510-3081 ; FAX : +82-51-512-9835

Professor, School of Mechanical Engineering, Pusan National University, 30, Jangjeon-dong, Kumjeong-gu, Pusan 609-735, Korea. (Manuscript Received August 9, 2000; Revised December 22, 2000)

al., 1995). However, this method also could not reduce chattering completely, because in determining the control input for compensating disturbances, changes in the state value were not considered.

This study proposes a fuzzy-sliding mode control algorithm to reduce almost completely chattering in sliding mode control, by using fuzzy rules within a pre-determined dead zone. This proposed algorithm considers not only the state values, but also changes in the state value to determine the control input for compensating disturbances. The selected fuzzy input variables are the state value of the phase plane and their change rate around the switching line. Fuzzy rules are also derived from these fuzzy variables. Also, the number of inference rules and the shape of the membership functions are determined by an expert with expert knowledge of robot systems.

In order to evaluate the reduction of chattering by the proposed fuzzy-sliding mode control, the trajectory tracking performance of the fuzzy-sliding mode control is compared with that of sliding mode control with the two dead zones by simulation. Trajectory tracking experiments with a SCARA robot are carried out to prove experimentally the result of the simulations. In this study, the proposed control algorithm is implemented on a SCARA robot with a DSP controller which is suitable for high speed calculations. Also, in order to evaluate the tracking performance in the case of payload changes, the trajectory tracking experiment of the robot with a payload is carried out by the proposed fuzzy-sliding mode control.

2. Design of the Fuzzy-Sliding Mode Controller

2.1 Sliding mode control

The four-axis SCARA robot modeled in this study is shown in Fig. 1. The dynamic equations of the SCARA robot can be written as

$$J_i \ddot{\theta}_i + B_i \dot{\theta}_i + F_i = k_i u_i \quad (1)$$

where J_i is the summation of all linear terms in the moment of inertia of link i and the driving

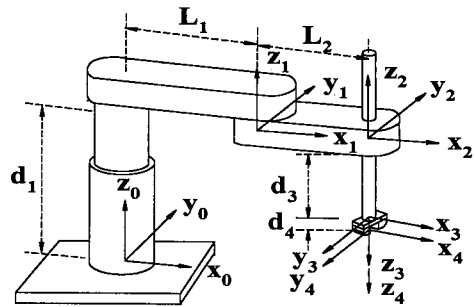

Fig. 1 SCARA robot

motor, and B_i is the equivalent damping coefficient from the motor, reduction gears, and the viscous friction of link i . The disturbance term F_i is the summation of the nonlinear terms of the inertia moments, the Coriolis and centrifugal force, the gravity force, and the Coulomb friction term. k_i is the constant determined from the motor torque coefficient, reduction rate of gears, and armature resistance. Finally, u_i is the control input voltage (Lee and Go, 1997; Lee and Shin, 1997; Lee, et al., 1998; Lee, et al., 1995).

A sliding mode control algorithm can be easily obtained from the simplified dynamic Eq. (1). Let the desired angle, angular velocity, and angular acceleration of link i be denoted by $\theta_{di}, \dot{\theta}_{di},$ and $\ddot{\theta}_{di}$, respectively, and the corresponding measured angular quantities denoted by $\theta_i, \dot{\theta}_i,$ and $\ddot{\theta}_i$, respectively. The error equations can be written as

$$e_i = \theta_i - \theta_{di} \quad \dot{e}_i = \dot{\theta}_i - \dot{\theta}_{di} \quad \ddot{e}_i = \ddot{\theta}_i - \ddot{\theta}_{di} \quad (2)$$

A switching line for the sliding mode can be expressed as

$$s_i = c_i e_i + \dot{e}_i \quad (3)$$

where s_i is the switching line of the link i and c_i is the corresponding slope.

In order to satisfy the existence condition of the sliding mode, when the unmodeled nonlinear terms are replaced by disturbances, a control input is proposed as follows:

$$u_i = \phi_{ai} e_i + \phi_{fi} + \phi_{\beta i} \dot{\theta}_{di} + \phi_{\gamma i} \ddot{\theta}_{di} \quad (4)$$

$$\phi_{ai} = \begin{cases} a_{1i} & \text{if } s_i e_i > 0 \\ a_{2i} & \text{if } s_i e_i < 0 \end{cases}$$

$$\phi_{\beta i} = \begin{cases} \beta_{1i} & \text{if } s_i \dot{\theta}_{di} > 0 \\ \beta_{2i} & \text{if } s_i \dot{\theta}_{di} < 0 \end{cases}$$

$$\psi_{\gamma i} = \begin{cases} \gamma_{1i} & \text{if } s_i \ddot{\theta}_{di} > 0 \\ \gamma_{2i} & \text{if } s_i \ddot{\theta}_{di} < 0 \end{cases}$$

$$\psi_{f_i} = \begin{cases} u_{f_i}^- = M_{1i} + M_{2i} \times |e_i| & \text{if } s_i > 0 \\ u_{f_i}^+ = -M_{1i} - M_{2i} \times |e_i| & \text{if } s_i < 0 \end{cases}$$

where $\psi_{\beta i}$ and $\psi_{\gamma i}$ are feedforward control input terms to ensure the existence condition of the sliding mode against unfavorable effects of $\dot{\theta}_{di}$ and $\ddot{\theta}_{di}$ on trajectory tracking. ψ_{f_i} is the control input for compensating disturbances (Lee and Go, 1997; Lee and Shin, 1997; Lee, et al., 1998; Lee, et al., 1995).

There exists a sliding mode at link i when the existence condition $s_i \dot{s}_i < 0$ is satisfied. From Eqs. (1) and (4), the existence condition of the sliding mode can be derived as follows:

$$\begin{aligned} s_i \dot{s}_i &= s_i (c_i \dot{e}_i + \ddot{e}_i) \\ &= s_i^2 \left(c_i - \frac{B_i}{J_i} \right) + s_i e_i \left(\frac{B_i}{J_i} c_i + \frac{k_i}{J_i} \psi_{a_i} \right. \\ &\quad \left. - c_i^2 \right) + \left(\frac{k_i}{J_i} \psi_{f_i} - \frac{F_i}{J_i} \right) s_i + \left(\frac{k_i}{J_i} \psi_{\beta i} \right. \\ &\quad \left. - \frac{B_i}{J_i} \right) s_i \dot{\theta}_{di} + \left(\frac{k_i}{J_i} \psi_{\gamma i} - 1 \right) s_i \ddot{\theta}_{di} < 0 \quad (5) \end{aligned}$$

If all terms in Eq. (5) are negative, the existence condition of the sliding mode is always satisfied. And, Eq. (5) can also be used to obtain the limit values of all the switching parameters in Eq. (4). When the first term in Eq. (5) is negative, the limit values of the switching parameters can be derived as follows:

$$\begin{cases} k_i \alpha_{1i} + B_i c_i - J_i c_i^2 < 0 & \text{if } s_i e_i > 0 \\ k_i \alpha_{2i} + B_i c_i - J_i c_i^2 > 0 & \text{if } s_i e_i < 0 \end{cases} \quad (6)$$

$$\begin{cases} u_{f_i}^- = M_{1i} + M_{2i} \times |e| < F_i / k_i & \text{if } s_i > 0 \\ u_{f_i}^+ = -M_{1i} - M_{2i} \times |e| > F_i / k_i & \text{if } s_i < 0 \end{cases} \quad (7)$$

$$\begin{cases} k_i \beta_{1i} - B_i < 0 & \text{if } s_i \dot{\theta}_{di} > 0 \\ k_i \beta_{2i} - B_i > 0 & \text{if } s_i \dot{\theta}_{di} < 0 \end{cases} \quad (8)$$

$$\begin{cases} k_i \gamma_{1i} - J_i < 0 & \text{if } s_i \ddot{\theta}_{di} > 0 \\ k_i \gamma_{2i} - J_i > 0 & \text{if } s_i \ddot{\theta}_{di} < 0 \end{cases} \quad (9)$$

For multi-input sliding mode control, the switching control input ψ_{f_i} should be supplied by a control hierarchy method (Lee and Aoshima, 1993). The control hierarchy used in this study is a hybrid method that can eliminate gravity effects of each link and interactions between the links. The hybrid method switches proportional control to sliding mode control for links of lower order as soon as the links of higher order come into quasi-

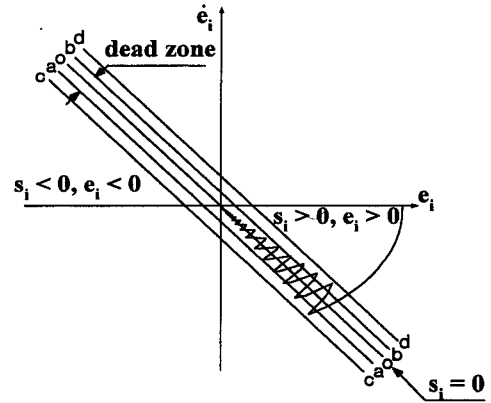

Fig. 2 Phase plane with a pre-determined dead zone around the switching line

sliding mode. That is, if the state variables of higher order satisfy $|s_i| < \epsilon_i$, those of lower order enter the sliding mode, and all the state variables to the lowest order gradually enter the sliding mode.

The phase plane for the error states of each link is shown in Fig. 2. Line o-o is the switching line of $s_i = 0$. Lines c-c and d-d are the additional lines used to determine whether the higher order class converges to the sliding mode in the hierarchical control or not. The magnitude of chattering, which is the distance between the switching line and the state variable, is denoted by D and expressed as

$$D = \frac{|c_i e_i + \dot{e}_i|}{\sqrt{c_i^2 + 1}} \quad (10)$$

In the previous study, a pre-determined dead zone is introduced and its width is described by $D = \epsilon$ between lines a-a and b-b to reduce chattering. Reduction of chattering can be made by changing the value of M_{1i} in ψ_{f_i} of the control input to a smaller value once the state variable falls into the dead zone (Lee and Go, 1997; Lee and Shin, 1997; Lee, et al., 1998; Lee, et al., 1995). However, this method could not reduce chattering completely because in determining ψ_{f_i} for compensating disturbances, changes in the state value were not considered.

2.2 Fuzzy-sliding mode control

In order to reduce almost completely chattering

in sliding mode control, this study proposes a fuzzy-sliding mode control algorithm. The proposed algorithm considers not only the state value but also its change to determine the control input for compensating disturbances. That is, the state values in the phase plane and its rate of change around the switching line are selected as the fuzzy input variables of the fuzzy-sliding mode controller. The fuzzy rules are derived from these fuzzy variables, and enable one to determine the control input for compensating disturbances. Therefore, the proposed fuzzy-sliding mode control reduces chattering by changing the sliding mode control input ψ_{fi} for compensating disturbances into the control input ψ_{fuzzy} selected by fuzzy rules within a pre-determined dead zone. The control input u_i of the fuzzy-sliding mode controller is proposed as follows:

$$u_i = \psi_{\alpha i} e_i + \psi_{fuzzy} + \psi_{\beta i} \dot{\theta}_{di} + \psi_{\gamma i} \ddot{\theta}_{di} \quad (11)$$

The fuzzy inputs of the proposed fuzzy-sliding mode control are S_{fi} and \dot{s}_{fi} , which are the fuzzified variables of the state value s_i and the change rate \dot{s}_i , respectively. The fuzzy output variable from the controller is u_{fi} , which is the fuzzified variable of ψ_{fuzzy} for compensating disturbances. All the universes of discourse of the fuzzified variables have specified universes which are performed by a fuzzifier (Cin and Lee, 1996). The fuzzifier performs the function of fuzzification which is a subjective valuation to transform measurement data into valuation of a subjective value. Hence, it can be defined as a mapping from an observed input space to labels of fuzzy sets in a specified input universe of discourse. Therefore, the range of variables s_i , \dot{s}_i , and ψ_{fuzzy} must be scaled to fit the universe of discourse of fuzzified variables S_{fi} , \dot{s}_{fi} , and u_{fi} with scaling factors K_1 , K_2 , and K_3 , respectively. These scaling factors are selected by an expert who has expert knowledge of robot systems. The control input ψ_{fuzzy} for compensating disturbances is determined by calculating the output of the fuzzy controller with the fuzzy rules and defuzzification.

In order to establish fuzzy rules, the movement of fuzzy input variables is examined on the phase plane. In Fig. 3, the state space at point P1

Table 1 Fuzzy rules

\dot{s}_{fi} / S_{fi}	PB	PM	ZO	NM	NB
PB	NB	NB	NM	NS	ZO
PM	NB	NM	NS	ZO	PS
ZO	NM	NS	ZO	PS	PM
NM	NS	ZO	PS	PM	PB
NB	ZO	PS	PM	PB	PB

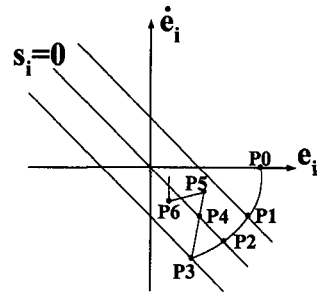

Fig. 3 Phase trajectory motion on the phase plane

represents the state in which s_i is strongly positive and \dot{s}_i is moderately negative. That is, S_{fi} is PB (positive big), \dot{s}_{fi} is NM (negative medium). In order to quickly approach the switching line without overshooting the line at this state, a fuzzy output u_{fi} must be selected as NS (negative small). The state space at point P2 represents the state that S_{fi} is ZO (zero), and \dot{s}_{fi} is NM (negative medium). Therefore, u_{fi} is selected as PM (positive medium) because this state is far away from the switching line. Also, by the same method, the fuzzy rule about other points P3, P4, and P5 can be established as follows:

- P1 : If S_{fi} is PB and \dot{s}_{fi} is NM, then u_{fi} is NS.
- P2 : If S_{fi} is ZO and \dot{s}_{fi} is NB, then u_{fi} is PM.
- P3 : If S_{fi} is NB and \dot{s}_{fi} is NB, then u_{fi} is PB.
- P4 : If S_{fi} is ZO and \dot{s}_{fi} is PB, then u_{fi} is NM.
- P5 : If S_{fi} is PM and \dot{s}_{fi} is PB, then u_{fi} is NB.

These rules are listed in Table 1. The fuzzy table consists of the fuzzified variables: a state value, its change rate, and a fuzzy output. The fuzzy inputs consist of five sets including PB, PM, ZO, NM, and NB (negative big). The fuzzy outputs consist of seven sets, i. e., PB, PM, PS (positive small), ZO, NS, NM, and NB. The

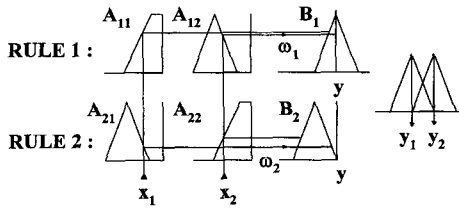

Fig. 4 Height method

number of inference rules and the shape of the membership functions are determined through trial and error method by an expert who has expert knowledge of robot systems.

Defuzzification is a mapping from a space of fuzzy control actions defined over an output universe of discourse into a space of nonfuzzy control actions. This process is necessary to apply to real systems, because in many practical applications crisp control action is required to actuate the control. This study uses the height method for defuzzification. The height method is simpler than the center of gravity method commonly used as a technique for defuzzification (Mohammad, et al., 1993; Robot, 1994). In order to explain the defuzzification process by the height method, two fuzzy rules are considered as follows:

RULE 1 : If x_1 is A_{11} and x_2 is A_{12} , then y_1 is B_1 .

RULE 2 : If x_1 is A_{21} and x_2 is A_{22} , then y_2 is B_2 .

where x_1 and x_2 are fuzzy input variables and y_1 and y_2 are the output variables. A_{11} , A_{12} , A_{21} , and A_{22} are the membership functions in the antecedent part, while, B_1 and B_2 are the membership functions in the consequent part.

The defuzzification process is shown in Fig. 4. A membership grade ω_1 and ω_2 are determined by RULE1 and RULE2, respectively. The consequent part is expressed by a real number y_1 and y_2 . The defuzzified result is simply derived as follows:

$$\omega_i = A_{i1}(x_1) \wedge A_{i2}(x_2) \tag{12}$$

$$y^o = \frac{\sum_{i=0}^n \omega_i y_i}{\sum_{i=0}^n \omega_i} \tag{13}$$

3. Simulation

In order to compare the reduction in chattering

Table 2 Specifications of SCARA robot

	Axis 1	Axis 2
Mass of link (kg)	15.07	8.99
Length of link (m)	0.35	0.30
Viscosity coefficient of link ($g_f \cdot cm/rpm$)	0.81	0.35
Inertia of motor ($g_f \cdot cm \cdot sec^2$)	0.51	0.14
Damping coefficient of motor ($kg_f \cdot cm$)	0.2	0.1
Electromotive force constant (V/krpm)	22.5	21.0
Torque constant ($kg_f \cdot cm/A$)	2.19	2.04

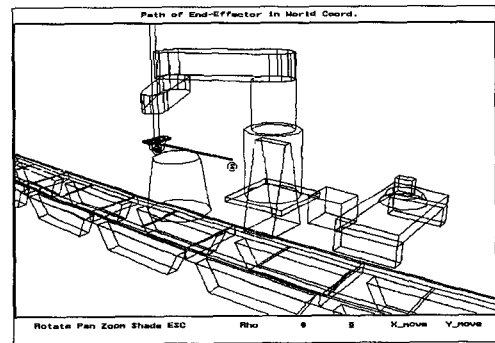

Fig. 5 Trajectory planning by the continuous path method

by the proposed fuzzy-sliding mode control with that by sliding mode control with two dead zones, a trajectory tracking simulation for a SCARA robot is carried out.

The desired trajectory is generated by teaching and trajectory planning on an off-line programming system (Son, et al., 1997). The corresponding joint angles and joint velocities are then calculated, and these angles and velocities are used as reference inputs for the trajectory tracking control. Figure 5 shows the trajectory planning results using the continuous path method (Son, et al., 1997). The simulation has been done for the case where the end-effector of the robot moved from the start point (400 mm, 150 mm) to the end point (400mm, -150 mm) in the x-y plane.

In order to determine the switching parameters for implementing the sliding mode control, the values of the inertia J_i and damping coefficient B_i of the SCARA robot are calculated by using the

specifications for the SCARA robot as listed in Table 2. The slopes of each switching line are selected by using the calculated J_i and B_i such that $c_1 < 161$ for axis 1 and $c_2 < 198$ for axis 2. The more the slope of the switching line is in the tolerated range, the shorter the rise time of the robot system. However, if this is applied to real systems, the required velocity component is increased on the sliding surface according to the

steepness of the slope of the switching line. Thus, in the case of industrial robot systems, these systems cannot follow the required velocity because of restrictions on the maximum torque and velocity (Lee and Go, 1997; Lee and Shin, 1997; Lee, et al., 1998; Lee, et al., 1995). Therefore, in this study, the slopes of the switching lines are selected such that $c_1=5$ and $c_2=5$ by considering characteristics of the SCARA robot. In

Table 3 Limit values of switching parameters

	Axis 1	Axis 2
c_i	$c_1=5$ ($c_1 < 161$)	$c_2=5$ ($c_2 < 198$)
α_i	$\alpha_{11} < -170.5$ $s_1 e_1 > 0$ $\alpha_{21} > -170.5$ $s_1 e_1 < 0$	$\alpha_{12} < -158.5$ $s_2 e_2 > 0$ $\alpha_{22} > -158.5$ $s_2 e_2 < 0$
β_i	$\beta_{11} < 35.2$, $s_1 \dot{\theta}_1 > 0$ $\beta_{21} > 35.2$, $s_1 \dot{\theta}_1 < 0$	$\beta_{12} < 32.5$, $s_2 \dot{\theta}_2 > 0$ $\beta_{22} > 32.5$, $s_2 \dot{\theta}_2 < 0$
γ_i	$\gamma_{11} < 0.22$, $s_1 \ddot{\theta}_1 > 0$ $\gamma_{21} > 0.22$, $s_1 \ddot{\theta}_1 < 0$	$\gamma_{12} < 0.165$, $s_2 \ddot{\theta}_2 > 0$ $\gamma_{22} > 0.165$, $s_2 \ddot{\theta}_2 < 0$

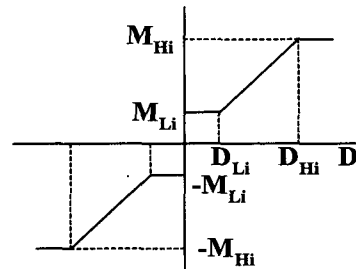
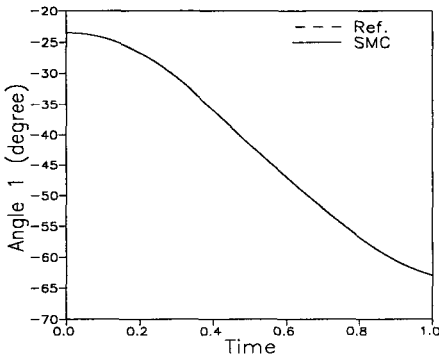
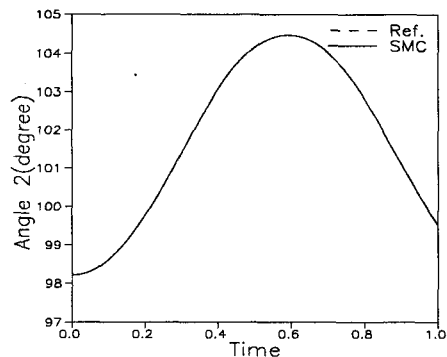

Fig. 6 Switching control input for compensating disturbances within two dead zones



(a) Axis 1



(b) Axis 2

Fig. 7 Angle of axis 1 and 2 by sliding mode control with two dead zones

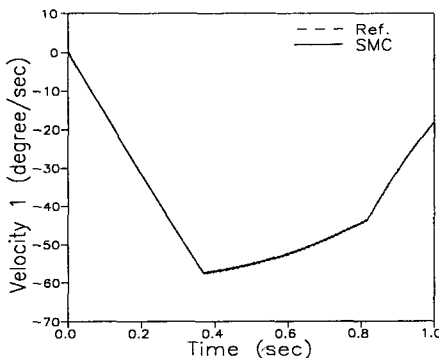

(a) Axis 1

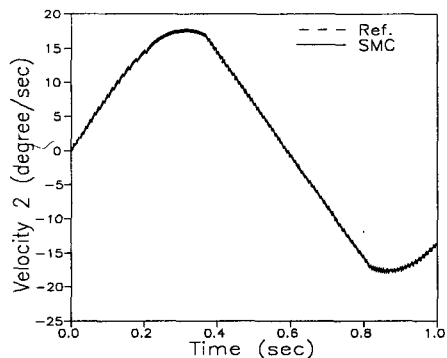

(b) Axis 2

Fig. 8 Velocity of axis 1 and 2 by sliding mode control with two dead zones

addition, the limit values of the switching parameters which satisfy the existence condition of a sliding mode are derived as listed in Table 3.

The multi-input sliding mode control of the robot manipulator is achieved by a hierarchical control method, where axis 1 has the highest order. Thus, after the sliding mode occurs at axis 1, the sliding mode successively occurs at axis 2.

First, in order to compare the tracking control performance of the proposed fuzzy-sliding mode

control with that of the sliding mode control, the trajectory tracking simulation is carried out by the sliding mode control with two dead zones. The shape of the control input ψ_{fi} in Eq. (4) within two dead zones is shown in Fig. 6. A reduction in chattering can be made by changing the value of M_{i_i} with a smaller value once the state variable falls into the two dead zones. The simulated results are shown in Figs. 7 and 8. Figures 7 and 8 show that the trajectory tracking error is very small, but that chattering still occurs.

Second, the trajectory tracking simulation is carried out by the fuzzy-sliding mode control to reduce chattering. The shape of the membership functions is determined as shown in Fig. 9 through a trial and error method by an expert in robotics. For defuzzifying, this study uses the height method as shown in Fig. 4, and the fuzzy rules are used as listed in Table 1. The selected scaling factors are $K_1=0.4$, $K_2=0.2$, $K_3=7$ for

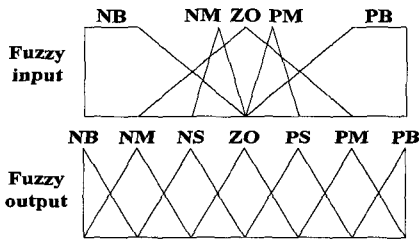
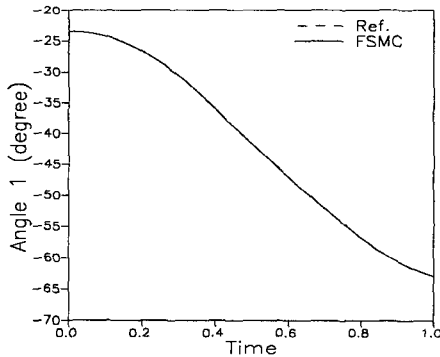
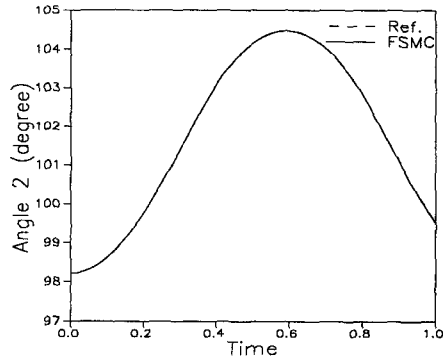

Fig. 9 Membership function



(a) Axis 1



(b) Axis 2

Fig. 10 Angle of axis 1 and 2 by fuzzy-sliding mode control

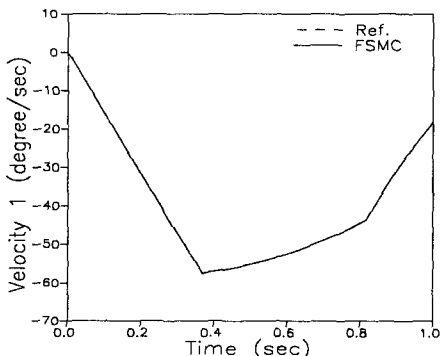

(a) Axis 1

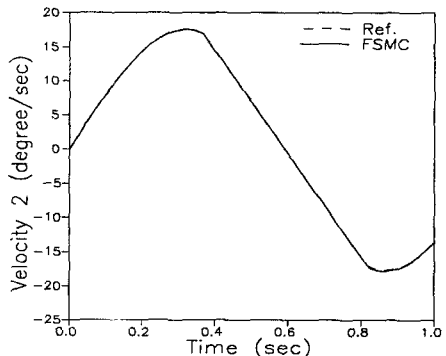

(b) Axis 2

Fig. 11 Velocity of axis 1 and 2 by fuzzy-sliding mode control

axis 1 and $K_1=0.2, K_2=0.2, K_3=5$ for axis 2. The simulated results by the fuzzy-sliding mode control are shown in Figs. 10 and 11. Figure 10 shows that the trajectory tracking error of the fuzzy-sliding mode control is almost similar to that of the sliding mode control with the two dead zones. However, comparing Fig. 8 with Fig. 11, the reduction in chattering achieved by the fuzzy-sliding mode control is superior to that by the sliding mode control with two dead zones.

4. Experiment

4.1 Trajectory Tracking Control

In order to investigate experimentally the trajectory tracking performance of the proposed fuzzy-sliding mode control algorithm, the control system is composed of a host computer, a DSP board, an interface board, a servo drive, and a SCARA robot as shown in Fig. 12. The DSP board for real-time signal processing is used to control the first two links of the robot. The FARA SM2 robot of SCARA type is manufactured by Samsung Electronics Company, and the specifications of this robot are listed in Table 2. However, these values cannot be used directly to determine the switching parameters because the composed robot system includes nonlinear terms. Therefore, this study uses the signal compression method which identifies unknown parameters of the system: the inertia moment or damping coefficient (Lee and Aoshima, 1989; Lee and Go, 1997; Lee and Shin, 1997; Lee, et al., 1998; Lee, et al., 1995). By using the signal compression method, the unknown parameters of the robot system are

estimated as listed in Table 4. When slopes of switching line are $c_1=4$ and $c_2=4$, the limit values of the switching parameters which satisfy the existence condition of the sliding mode are derived as listed in Table 5. And, the experiment uses the same trajectory as in the simulation.

First, the trajectory tracking experiment is carried out by the sliding mode control with two dead zones. The control input ψ_{fi} has the same shape as in the simulation. The experimental results are shown in Figs. 13 and 14. Second, the trajectory tracking experiment is carried out by the proposed fuzzy-sliding mode control. The shape of the membership function and the fuzzy rules are the same as those of the simulations. The

Table 4 System parameters of SM2 robot

	ω_{ni} (rad/sec)	ξ_i	J_i (Kg·m ²)	B_i (Kg·m ² /s)
Axis 1	5.4	0.26	0.20438	1.2703
Axis 2	5.1	0.31	0.06162	0.7864

Table 5 Limit values of switching parameters by using the signal compression method

	Axis 1	Axis 2
c_i	$c_1=4$ ($c_1 < 6.215$)	$c_2=4$ ($c_2 < 12.762$)
a_i	$a_{11} < -0.379, s_1 e_1 > 0$ $a_{21} > -0.379, s_1 e_1 < 0$	$a_{12} < -1.7, s_2 e_2 > 0$ $a_{22} > -1.7, s_2 e_2 < 0$
β_i	$\beta_{11} < 0.266, s_1 \dot{\theta}_1 > 0$ $\beta_{21} > 0.266, s_1 \dot{\theta}_1 < 0$	$\beta_{12} < 0.652, s_2 \dot{\theta}_2 > 0$ $\beta_{22} > 0.652, s_2 \dot{\theta}_2 < 0$
γ_i	$\gamma_{11} < 0.0428, s_1 \ddot{\theta}_1 > 0$ $\gamma_{21} > 0.0428, s_1 \ddot{\theta}_1 < 0$	$\gamma_{12} < 0.485, s_2 \ddot{\theta}_2 > 0$ $\gamma_{22} > 0.485, s_2 \ddot{\theta}_2 < 0$

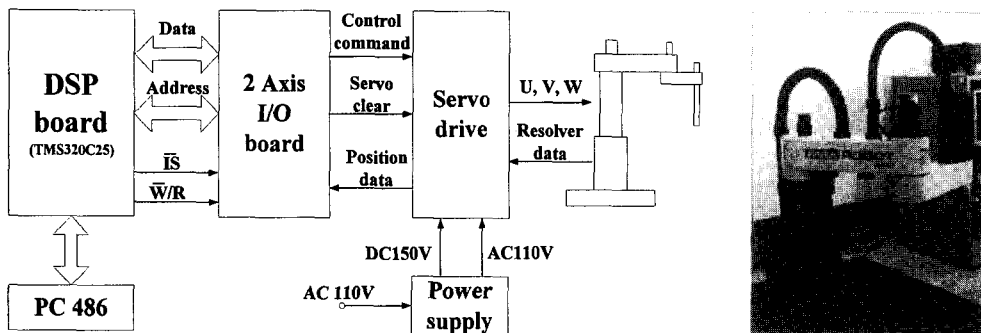

Fig. 12 Block diagram of control system and SM2 robot

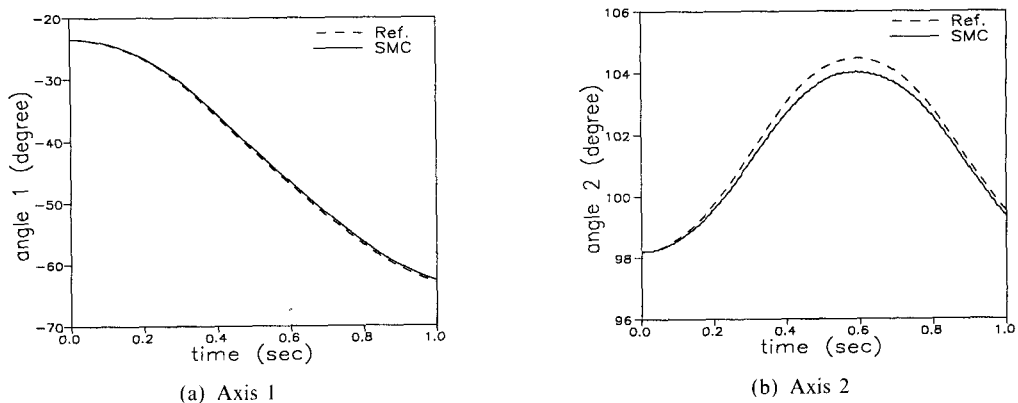

Fig. 13 Angle of axes 1 and 2 by sliding mode control with two dead zones

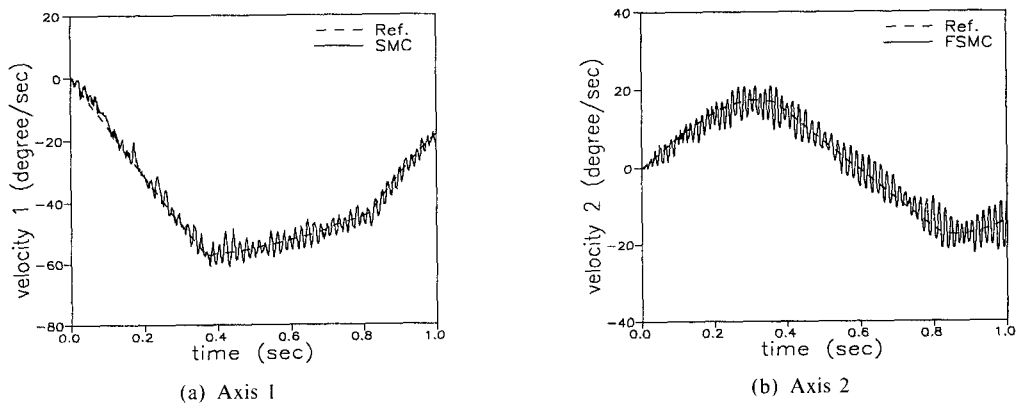

Fig. 14 Velocity of axes 1 and 2 by sliding mode control with two dead zones

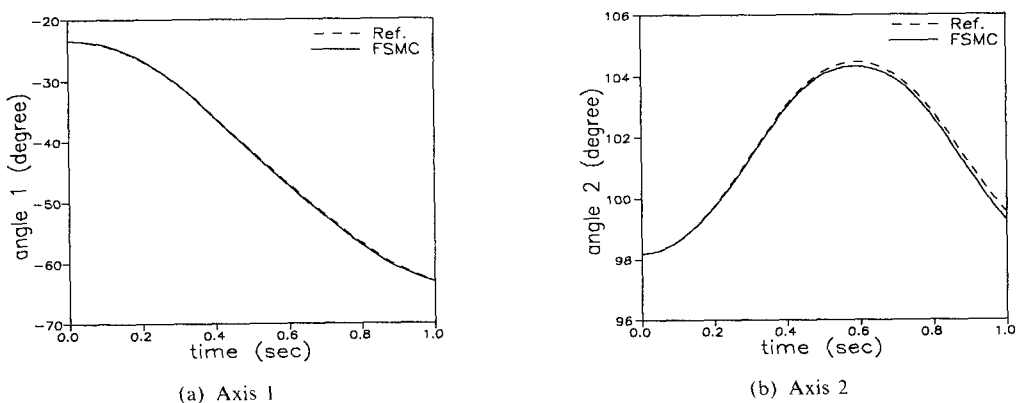
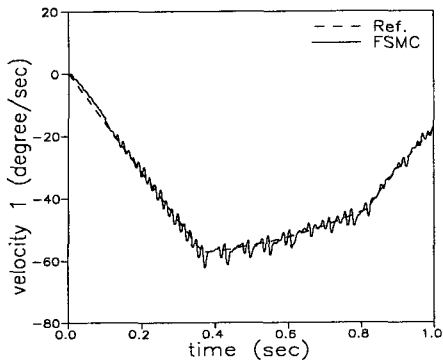

Fig. 15 Angle of axes 1 and 2 by fuzzy-sliding mode control without payload

selected scaling factors are $K_1=40$, $K_2=30$, $K_3=0.2$ for axis 1 and $K_1=45$, $K_2=35$, $K_3=0.15$ for axis 2. The experimental results by the fuzzy-sliding mode control are shown in Figs. 15 and 16.

Comparing Fig. 13 with Fig. 15, the tracking error achieved by the fuzzy-sliding mode control is less than that by the sliding mode control with two dead zones. Also, comparing Fig. 14 with Fig. 16, the reduction in chattering achieved by



(a) Axis 1

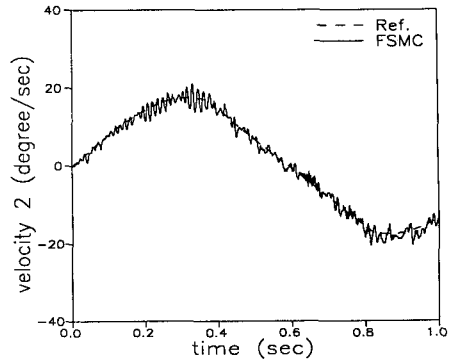

(b) Axis 2

Fig. 16 Velocity of axes 1 and 2 by fuzzy-sliding mode control without payload

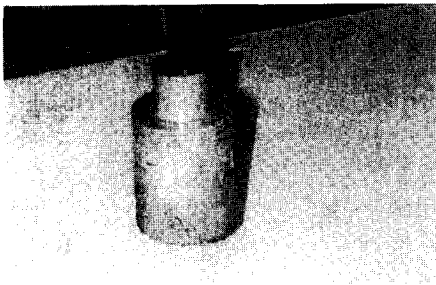
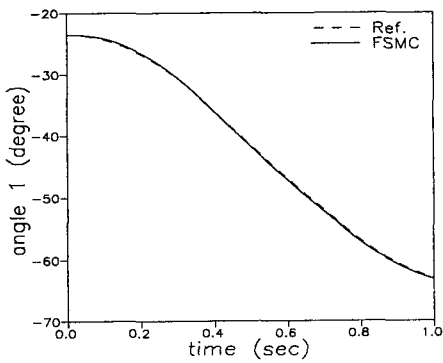
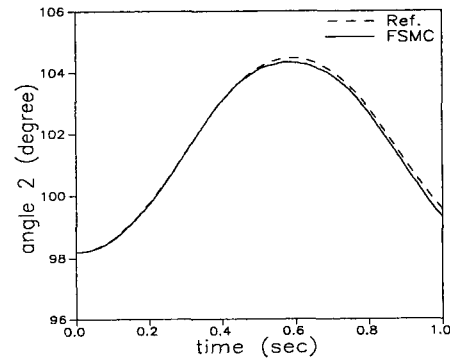

Fig. 17 Payload



(a) Axis 1



(b) Axis 2

Fig. 18 Angle of axes 1 and 2 by fuzzy-sliding mode control with 4 kg payload

the fuzzy-sliding mode control is superior to that by the sliding mode control with two dead zones.

4.2 Robustness

In order to evaluate tracking performance in the case of payload changes, a trajectory tracking experiment of the robot manipulator with a pay-

load is carried out by the fuzzy-sliding mode control while the control gains remain unchanged. Figure 17 shows the used payloads. The gripper of axis 4 is equipped with a 4 kg payload. The experimental results are shown in Figs. 18 and 19. The results show that the proposed algorithm can provide reliable and robust tracking

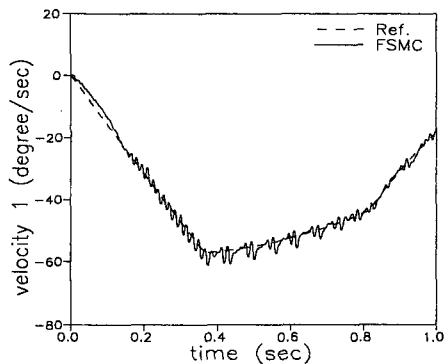

(a) Axis 1

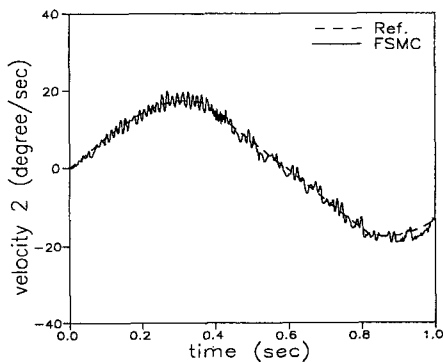

(b) Axis 2

Fig. 19 Velocity of axes 1 and 2 by fuzzy-sliding mode control with 4 kg payload

performance against payload changes.

5. Conclusions

This study proposed a fuzzy-sliding mode control algorithm to reduce chattering in sliding mode control. In order to compare the reduction in chattering by the proposed fuzzy-sliding mode control with that by sliding mode control with two dead zones, trajectory tracking simulations and experiments with a SCARA robot are carried out. The trajectory tracking simulations and experiments show that the tracking error achieved by the fuzzy-sliding mode control is less than that by the sliding mode control with two dead zones, and the overall reduction in chattering by the fuzzy-sliding mode control is superior to that by the sliding mode control with two dead zones. To evaluate the robustness of the proposed control

algorithm, the gripper of axis 4 was equipped with a 4 kg payload. Experimental results showed that the proposed algorithm can provide reliable and robust tracking performance against payload changes. However, the number of inference rules and the shape of the membership functions of the fuzzy-sliding mode controller should be determined only by an expert who has expert knowledge of robot systems. Thus, if the plant is changed, the expert must modify the algorithm. It is a time-consuming and tedious job to find the optimal inference rules. In order to solve this difficulty, future studies will consider applying genetic algorithms to this problem.

Acknowledgments

This research was supported by the Korea Science and Engineering Foundation (KOSEF) through the Engineering Research Center for Net Shape and Die Manufacturing at Pusan National University, and by the Brain Korea 21 Project.

References

- Cin, C. T. and Lee, C. S. G., 1996, *Neural Fuzzy System*, Prentice-Hall.
- Dong, Y. and Shifan, Xu, 1996, "sliding Mode Control of Singular Perturbation Systems," *IEEE Int. Conference on System, Man and Cybernetics*, pp. 113~116.
- Fu, K. S., Gonzalez, R. C. and Lee, C. S. G., 1987, *Robotics*, McGraw-Hill.
- Furuta, T. and Tomiyama, K., 1996, "Sliding Mode Controller with Time-Varying Hyperplane," *Proc. of the IEEE/RSJ Int. Conference on Intelligent Robots and Systems*, pp. 576~581.
- Harashima, F., Hashimoto, H. and Maruyama, K., 1986, "Sliding Mode Control of Manipulator with Time-Varying Switching Surfaces," *Trans. of SICE*, Vol. 22, No. 3, pp. 335~342.
- Hashimoto, H., Maruyama, K. and Harashima, F., 1987, "A Microprocessor-Based Robot Manipulator Control with Sliding Mode," *IEEE Trans. Industrial Electronics*, Vol. 34, No. 1, pp. 11~18.
- Lee, M. C. and Aoshima, N., 1989, "Identifica-

tion and Its evaluation of the System with a Nonlinear Element by Signal Compression Method," *Trans. of SICE*, Vol. 25, No. 7, pp. 729~736.

Lee, M. C. and Aoshima, N., 1993, "Real Time Multi-Input Sliding Mode Control of a Robot Manipulator Based on DSP," *Proc. of SICE*, pp. 1223~1228.

Lee, M. C. and Go, S. J., 1997, "Real Time Fuzzy-Sliding Mode Control for SCARA Robot Based on DSP," *Proc. of 2nd Asian Control Conference*, Vol. II, pp. 599~602.

Lee, M. C. and Shin, K. T., 1997, "Development of a Dynamic Simulator for SCARA Robot Using Sliding Mode Control," *KSME (A)*, Vol. 21, No. 4, pp. 535~548.

Lee, M. C., Son, K. and Lee, J. M., 1998, "Improving Tracking Performance of Industrial SCARA Robots Using a New Sliding Mode Control Algorithm," *KSME International Journal*, Vol. 12, No. 5 pp. 761~772.

Lee, M. C., Son, K., Lee, J. M., Lee, M. H.,

Ahn, D. S. and Han, S. H., 1995, "Implementation of a New Sliding Mode Control for SCARA ROBOT," *Proc. of the '95 American Control Conference*, Vol. 2 of 6, pp. 1387~1391.

Mohammad, J., Nader, U. and Timothy, J. R., 1993, *Fuzzy Logic and Control*, Prentice-Hall.

Robot, J. M., 1994, *Fuzzy logic Technology and Applications*, IEEE Technical Activities Board.

Slotine, J. J. E., 1985, "The Robust Control of Robot Manipulators," *Int. Journal of Robotics Research*, Vol. 4, No. 4, pp. 49~64.

Son, K., Lee, M. C., Lee, J. M., Han, S. H., Lee, M. H. and Kim, S. K., 1997, "Real-Time Evaluation of an Off-Line Programming System for SCARA Robot," *Proc. of 2nd Asian Control Conference*, Vol. I, pp. 89~92.

Young, K. K. D., 1978, "Controller Design for Manipulator Using Theory of Variable Structure Systems," *IEEE Trans. on System, Man and Cybernetics*, Vol. 8, No. 2, pp. 101~109.