

## Stress Intensity Factors for Elliptical Arc Through Cracks in Mechanical Joints by Virtual Crack Closure Technique

Sung Pil Heo\*, Won Ho Yang, Cheol Kim

*School of Mechanical Engineering, Sungkyunkwan University, Suwon, Kyunggi-do 440-746, Korea*

The reliable stress intensity factor analysis is required for fracture mechanics design or safety evaluation of mechanical joints at which cracks often initiate and grow. It has been reported that cracks in mechanical joints usually nucleate as corner cracks at the faying surface of joints and grow as elliptical arc through cracks. In this paper, three dimensional finite element analyses are performed for elliptical arc through cracks in mechanical joints. Thereafter stress intensity factors along elliptical crack front including two surface points are determined by the virtual crack closure technique. Virtual crack closure technique is a method to calculate stress intensity factor using the finite element analysis and can be applied to non-orthogonal mesh. As a result, the effects of clearance on the stress intensity factor are investigated and crack shape are then predicted.

**Key Words :** Stress Intensity Factor, Elliptical Arc Through Crack, Virtual Crack Closure Technique, Finite Element Analysis, Mechanical Joint, Clearance, Contact

### 1. Introduction

Mechanical joints like bolted or riveted joints are widely used to join the constituent parts of a structure. Cracks often initiate and grow at joint because of stress concentration and contact. So that stress intensity factor analysis of an arbitrary crack in joint is required for fracture mechanics design or safety evaluation.

Fracture mechanics analyses on cracks in mechanical joints have been performed mainly for two dimensional cracks. Cartwright and Parker (1982) analyzed the stress intensity factors for symmetric cracks with assuming contact pressure in mechanical joints to be uniform or cosine distribution. Narayana et al. (1994) investigated the effects of interference and clearance on stress

intensity factors, and Ju (1997) analyzed mixed-mode stress intensity factors for both horizontal and inclined cracks in mechanical joints.

Fawaz (1998, 1999) has reported from fractographic observations on fatigued joints that cracks in mechanical joints usually nucleate from corner cracks at the faying surface of joints and grow to be elliptical arc through cracks as shown in Fig. 1. Stress intensity factors for elliptical corner cracks in joints as an initial model of crack growth have been analyzed by some researchers (Shivakumar and Newman Jr. , 1991; Lin and Smith, 1999), but those of elliptical arc through cracks have rarely been dealt with. Fawaz (1998, 1999) analyzed stress intensity factors for elliptical arc through crack using the virtual crack closure technique not considering the contact area in joints and analyzing mode I stress intensity factor of symmetric cracks only. In mechanical joints, there is usually a clearance between the fastener hole and the bolt or rivet. The effects of clearance on cracks in mechanical joints may not be evaluated by Fawaz's model excluding contact condition. Consequently the stress intensity factor should be estimated for a single elliptical arc

\* Corresponding Author,

E-mail : spheo@orgio.net

TEL : +82-31-290-7496; FAX : +82-31-290-5849

Fracture Mechanics Lab., School of Mechanical Engineering, Sungkyunkwan University, Chunchun-dong, Jangan-gu, Suwon, Kyunggi-do 440-746, Korea. (Manuscript Received April 9, 2001; Revised November 28, 2001)

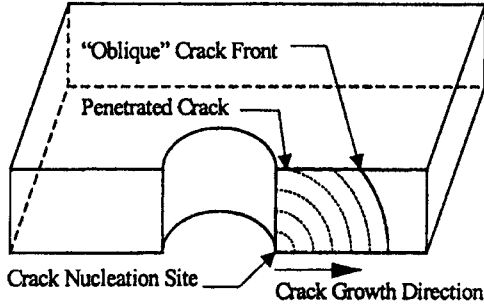

Fig. 1 Crack growth profile in mechanical joints (Fawaz, 1999)

through crack of more practical crack model with contact area.

Virtual crack closure technique is a method to calculate stress intensity factor using nodal forces on and ahead of the crack tip and nodal displacements behind it from results of finite element analysis. Also it is possible to apply the virtual crack closure technique in case that orthogonal mesh cannot be modeled such as elliptical arc through cracks.

In this paper, three-dimensional finite element analyses are performed for elliptical arc through cracks in mechanical joints with including contact area in the joints. And mixed-mode stress intensity factors are determined by applying the virtual crack closure technique. As a result we applied the virtual crack closure technique to semi-elliptical and elliptical arc through cracks, and analyzed mode I, mode II and mode III stress intensity factors along the elliptical crack front including two surface points. The effects of the amount of clearance on stress intensity factors are also investigated and crack shape is then predicted. Finally an elliptical arc through crack model is compared with a two-dimensional crack one.

## 2. Virtual Crack Closure Technique

The virtual crack closure technique is used to determine energy release rate from work needed to close virtual crack. As shown in Fig. 2, for in finitesimal  $\Delta$ , the work for extending the crack from  $a$ (real crack) to  $a+\Delta$ (virtual crack) is the

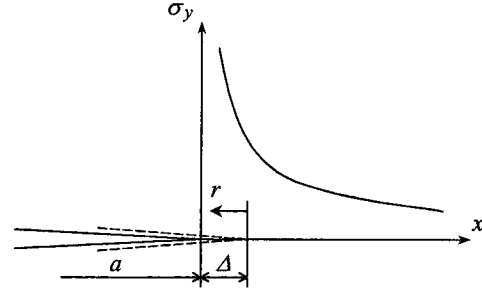

Fig. 2 Normal stress distribution ahead of crack tip

same amount  $W$ , to close the crack from  $a+\Delta$  to  $a$ .

$$W = \frac{1}{2} \int_0^{\Delta} v(r) \sigma_y(\Delta - r) dr \quad (1)$$

where  $v$  is the crack surface displacement and  $\sigma_y$  is the stress field ahead of the crack tip. Then energy release rate  $G$  can be calculated by dividing the work  $W$ , by the virtual crack increment  $\Delta$ ,

$$G = \frac{W}{\Delta} = \frac{1}{2\Delta} \int_0^{\Delta} v(r) \sigma_y(\Delta - r) dr \quad (2)$$

The energy release rate is related to stress intensity factor as Eq. (3) for plane stress and as Eq. (4) for plane strain respectively.

$$K = \sqrt{GE} \quad \text{for plane stress} \quad (3)$$

$$K = \sqrt{GE/(1-\nu^2)} \quad \text{for plane strain} \quad (4)$$

Figure 3 shows a typical finite element mesh at crack surface for a three-dimensional crack. The strain energy release rate  $G_i$  in the  $i$ -th element along crack front is calculated from the virtual work to close the crack surface area,  $\Delta \times w_i$ ,

$$G_i = \frac{1}{2\Delta w_i} \int_{s_{i-1}}^{s_{i+1}} \int_0^{\Delta} v(r, s) \sigma_y(\Delta - r, s) dr ds \quad (5)$$

On the calculation of energy release rate by Eq. (5) from finite element method, nodal forces and displacements are used respectively for stress and displacement fields by using shape functions of the element. For a model consisting of 20-node

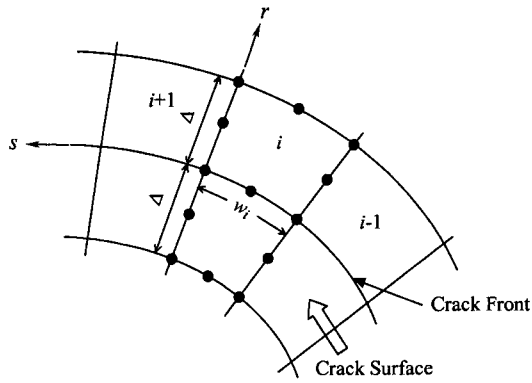

Fig. 3 Typical finite element mesh at the crack surface for three dimensional crack

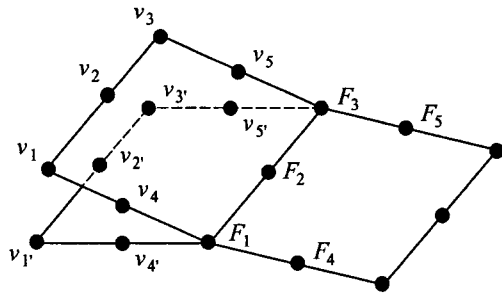

Fig. 4 Node identification in 20-node isoparametric elements for virtual crack closure technique

isoparametric elements as in Fig. 4, the energy release rate can be expressed as (Shivakumar et al., 1988)

$$G_i = \frac{1}{2\Delta w_i} \sum_{j=1}^5 F_j^i (v_j - v_{j'})$$

$$= \frac{1}{2\Delta w_i} [F_1^i (v_1 - v_{1'}) + F_2^i (v_2 - v_{2'}) + F_3^i (v_3 - v_{3'}) + F_4^i (v_4 - v_{4'}) + F_5^i (v_5 - v_{5'})] \quad (6)$$

where  $F_j^i$  is nodal forces on the  $i$ -th element and  $v_j$  and  $v_{j'}$  are the relative nodal displacements to the crack tip. Subscripts indicate node numbers shown in Fig. 4.

Equation (6) can also be applied to mode II or mode III for nodal forces and displacements causing mode II or mode III deformation.

There are several methods to calculate stress intensity factor using finite element analyses such as COD (crack opening displacement) method, nodal force method, extrapolation method, etc.

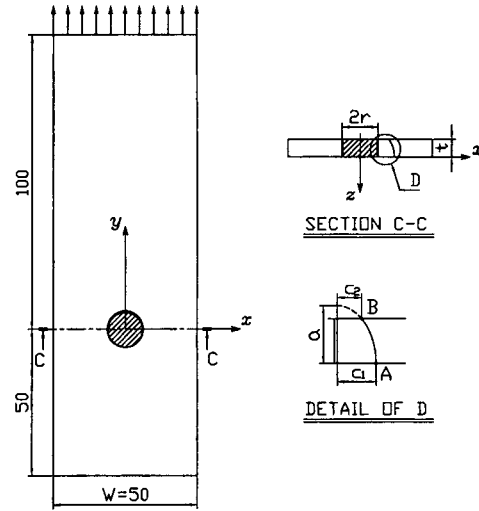

Fig. 5 Configuration of an elliptical arc through crack in a mechanical joint

and collapsed singular elements are used for modeling the crack as in most methods. In the virtual crack closure technique, however, it is possible to construct a finite element mesh using normal elements near crack tip. Another advantage of the technique, as will be discussed later, is that orthogonal mesh does not have to be used near crack tip.

### 3. Finite Element Analysis

#### 3.1 Analysis model

A plate has an elliptical arc through crack in mechanical joints and is subjected to remote uniform tension. Figure 5 shows the geometry and coordinate system where  $c_1$  and  $c_2$  represent the crack length at the two surfaces, and crack depth is  $a$ . The material used in this analysis is aluminium with Young's modulus,  $E=68.95$  GPa and Poisson's ratio,  $\nu=0.25$ . Besides, behavior of the aluminium is assumed to be linearly elastic.

#### 3.2 Orthogonal and non-orthogonal mesh

A three-dimensional crack such as surface or corner cracks is commonly modeled as elliptical shape. The COD method is widely used to calculate stress intensity factor for an elliptical crack by using the nodal displacements of crack surface. However, the COD method can be applied for

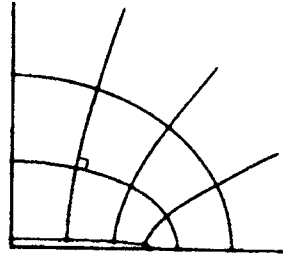

Fig. 6 Orthogonality for elliptical crack mesh

orthogonal mesh where mesh lines across elliptical crack front are normal to the crack front as shown in Fig. 6. Orthogonal mesh can be made for general quarter-elliptical or semi-elliptical crack, but part-elliptical shape such as a present elliptical arc through crack cannot have the perfect orthogonality near one end of part-ellipse. It can thus be stated that the stress intensity factors along the crack front of elliptical arc through crack cannot be calculated accurately from the COD method. It has been verified that the virtual crack closure technique can be applied to non-orthogonal mesh (Fawaz, 1998; 1999), and mode II and mode III stress intensity factors for three-dimensional crack as well as mode I can be obtained by decomposing the nodal force and nodal displacement. In this study, therefore, the mixed-mode stress intensity factors for elliptical arc through cracks in mechanical joints were analyzed by the virtual crack closure technique using the nodal forces and nodal displacements obtained from finite element analysis including contact area.

**3.3 Stress intensity factors for elliptical crack**

The three dimensional virtual crack closure technique is commonly used to calculate the energy release rate for each element along the crack front like Eq. (6). This corresponds to the average stress intensity factor of the element or the stress intensity factor at the mid-side node.

Raju et al. (1996) presented the energy release rate equation for corner nodes of a three-dimensional through crack. The energy release rates at the end node,  $n_1$ , and the internal node,  $n_3$  in Fig. 7 are given as

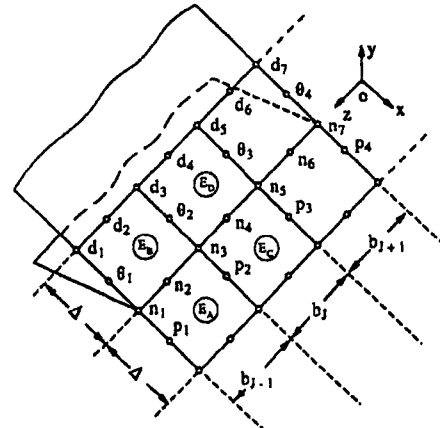

Fig. 7 Elements and nodes of three dimensional through crack (Raju et al., 1996)

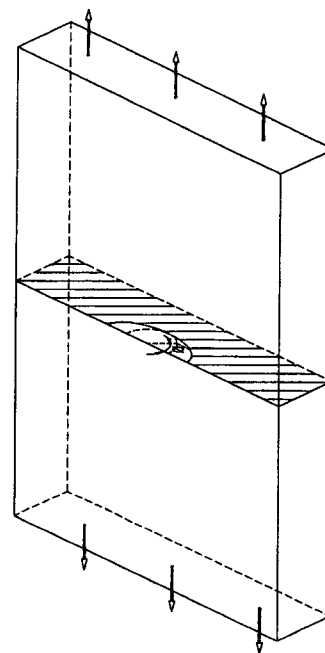
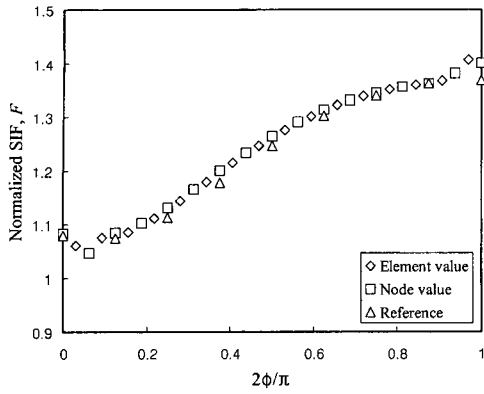

Fig. 8 Semi-elliptical surface crack in a finite-width plate

$$G_I |_{n_1} = \frac{1}{2\Delta b_{n_1}} [F_{y_{n_1}}(v_{d_1} - v_{d_1'}) + F_{y_{p_1}}(v_{\theta_1} - v_{\theta_1'})] + \frac{1}{2} F_{y_{n_2}}(v_{d_2} - v_{d_2'}) \quad (7)$$

$$G_I |_{n_3} = \frac{1}{2\Delta b_{n_3}} [\{ F_{y_{n_3}}(v_{d_3} - v_{d_3'}) + F_{y_{p_2}}(v_{\theta_2} - v_{\theta_2'}) \} + \frac{1}{2} \{ F_{y_{n_2}}(v_{d_2} - v_{d_2'}) + F_{y_{n_4}}(v_{d_4} - v_{d_4'}) \}] \quad (8)$$

where  $b_{n_1}$  and  $b_{n_3}$  are equivalent widths as



**Fig. 9** Stress intensity factors for elements and corner nodes of semi-elliptical surface crack in a finite-width plate

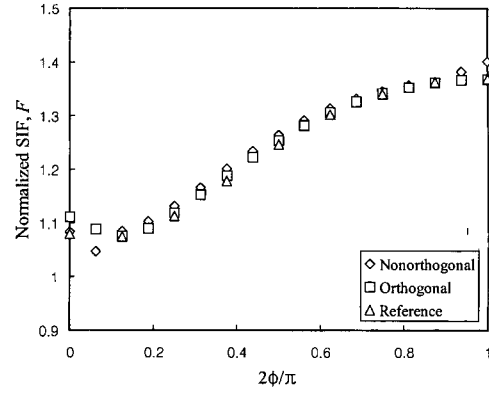

**Fig. 11** Stress intensity factors for semi-elliptical surface crack in a finite-width plate using orthogonal and non-orthogonal mesh

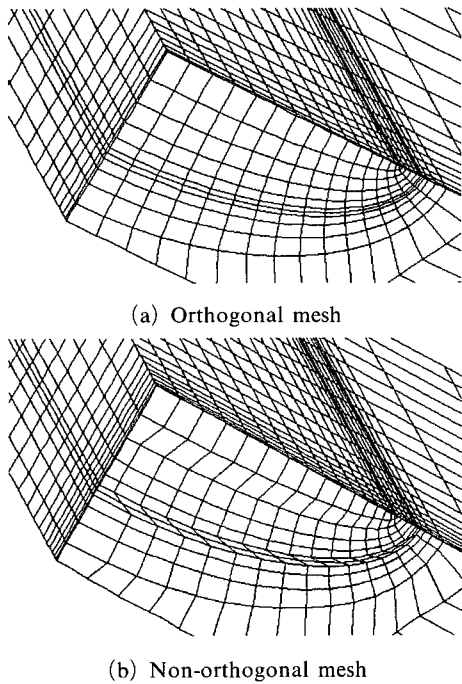

**Fig. 10** Finite element mesh for semi-elliptical surface crack in a finite-width plate

$$b_{n1} = \frac{1}{2} b_{j-1} \tag{9}$$

$$b_{ns} = \frac{1}{2} (b_{j-1} + b_j) \tag{10}$$

In order to calculate stress intensity factor along elliptical crack front including two surface points of elliptical arc through crack, the calculation of energy release rates at each node of

through crack like Eqs. (7), (8) was applied to elliptical crack.

Semi-elliptical surface crack in a finite-width plate in Fig. 8 was analyzed to prove the application of virtual crack closure technique to elliptical crack. Figure 9 shows the stress intensity factors obtained by the energy release rate equation for each element and equation for node. The stress intensity factors are normalized as

$$F = \frac{K}{\sigma \sqrt{\frac{\pi a}{Q}}} \tag{11}$$

where  $Q$  is the shape factor of ellipse.

It can be seen from the figure that the stress intensity factors for each element and node are continuously distributed along the elliptical crack front and agree well with Raju and Newman's results (1979). In order to validate the use of non-orthogonal mesh for elliptical crack, orthogonal and non-orthogonal mesh were constructed as shown in Fig 10(a) and (b). Figure 11 shows the stress intensity factors at the nodes along elliptical crack front obtained from two mesh types. It can be known that non-orthogonal mesh can be used to apply the virtual crack closure technique to elliptical crack problem.

### 3.4 Verification

The stress intensity factors were analyzed for symmetric elliptical arc through cracks at a fastener hole and they were compared with

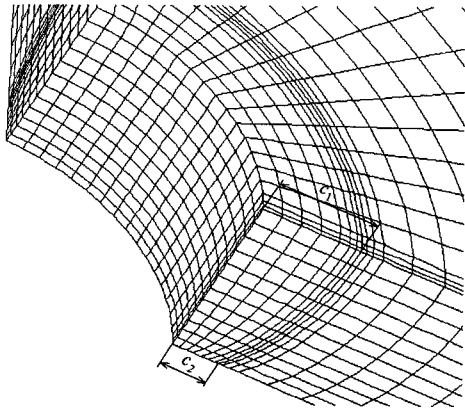

Fig. 12 Finite element mesh for symmetric elliptical arc through cracks at a fastener hole

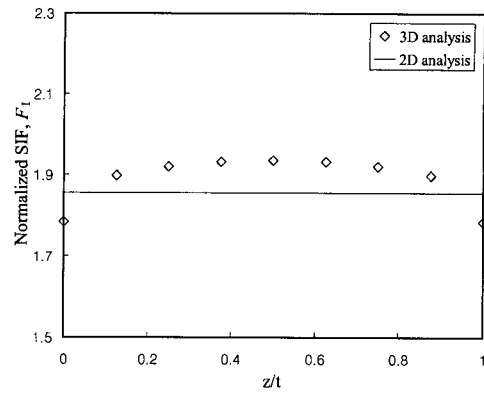
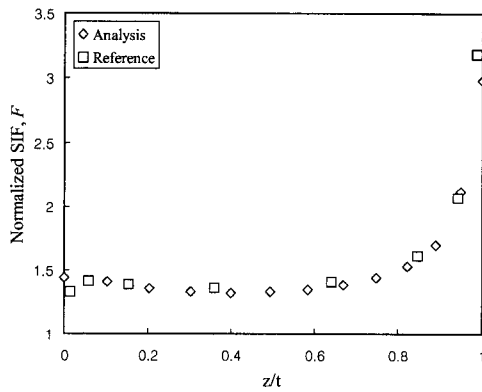
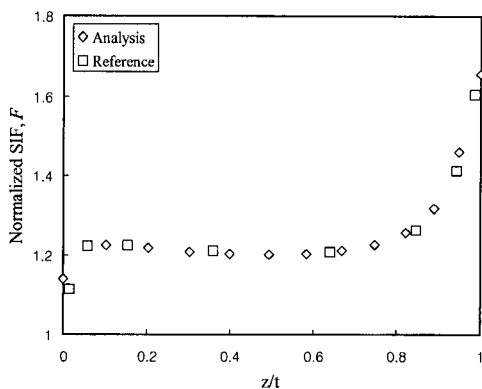

Fig. 14 Stress intensity factors along thickness of a through crack in mechanical joints



(a)  $a/c_1=0.6$



(b)  $a/c_1=2.0$

Fig. 13 Stress intensity factors for symmetric elliptical arc through cracks at a fastener hole

analyses were made using ABAQUS version 5.8 with non-orthogonal mesh proper to part-elliptical shape as shown in Fig. 12.

The finite element result of cracked body is much affected by the mesh near the crack tip and the proper size of crack tip element has to be set up. In order to determine the proper size, the stress intensity factor analyses were made for various sizes of crack tip element,  $\Delta$ , referring to the size suggested in Raju's paper(1987). The stress intensity factors were compared with Fawaz's results(1999) and the size of crack tip element was determined as  $\Delta/a=0.05$ .

Figure 13(a) and (b) show the stress intensity factors along thickness for crack depth ratio  $a/t=1.13$  and two crack shape ratios. It can be seen that present analysis results agree fairly with Fawaz's results(1999).

The stress intensity factors for a through crack in mechanical joints were analyzed including contact area and were plotted along thickness with the two-dimensional finite element results verified in author's paper(2001). The common difference between three-dimensional and two-dimensional analyses of a through crack without contact area is shown in Fig. 14. It can be stated from Figs. 13, 14 that the present finite element model and the calculation of stress intensity factors by virtual crack closure technique are verified for an elliptical arc through crack in mechanical joints.

Fawaz's results(1999). The finite element

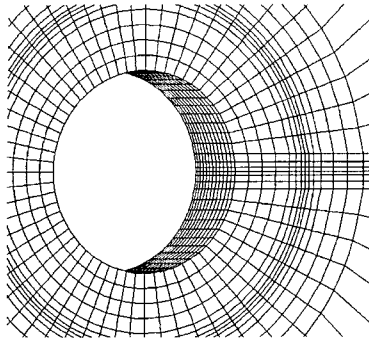

**Fig. 15** Finite element mesh for an elliptical arc through crack in mechanical joints

#### 4. Mixed-Mode Stress Intensity Factor

##### 4.1 Effects of the amount of clearance

Three-dimensional finite element analyses were performed for elliptical arc through cracks in mechanical joints and mode I, mode II and mode III stress intensity factors were determined by the virtual crack closure technique from the finite element results. In order to investigate the effects of clearance, the stress intensity factors were analyzed in the cases of no clearance and of clearance being 1%, 5% and 10% of hole diameter. In the finite element mesh of Fig. 15, rigid elements were used to represent a bolt and total number of 20-node isoparametric elements of the plate model is about 14500. The contact condition has to be specified between fastener hole and bolt, and thus the outer surface of the bolt and the inner surface of the hole were established as contact surface to prevent the relative penetration. The accuracy and convergence of contact analysis varies according to the size of element in the contact area and the allowable penetration is determined in proportion to the size of element. Fine mesh around the hole, therefore, was constructed to satisfy contact condition well between the hole and bolt.

Figure 16(a), (b) show the mode I stress intensity factors for elliptical arc through cracks in mechanical joints for two crack shapes. In the figures,  $z/t=0$  represents tip A and  $z/t=1$ , tip B as shown in Fig. 5. It can be seen that the mode

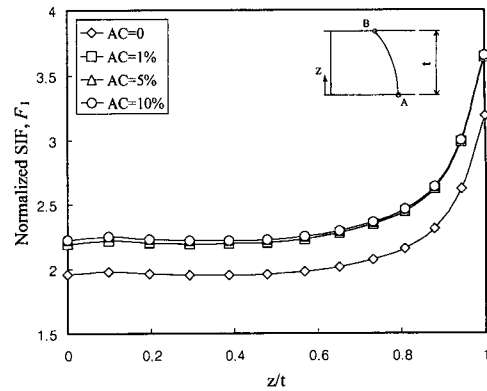

(a)  $a/t=1.2$ ,  $a/c_1=1.5$

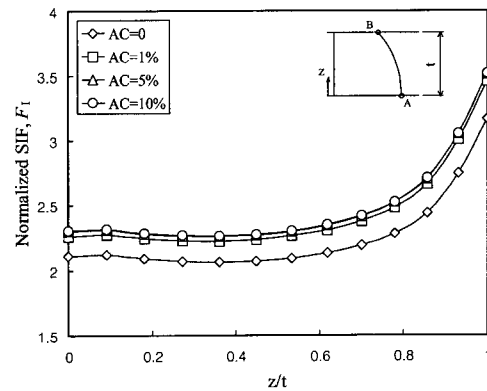

(b)  $a/t=1.5$ ,  $a/c_1=0.9$

**Fig. 16** Mode I stress intensity factors for elliptical arc through cracks in mechanical joints for different clearance conditions

I stress intensity factors near tip B sharply increase for all clearance conditions and crack shapes. This indicates that if initial corner cracks in mechanical joints become elliptical arc through cracks after penetrating through the plate thickness, tip B propagates more quickly than tip A and the elliptical front shape of the elliptical arc through crack approaches to straight line.

It can also be seen from the figures that the mode I stress intensity factors in the cases of clearance are much larger than those without clearance, but the amount of clearance has little effects on the stress intensity factors for clearance. It can thus be known that the stress intensity factors for elliptical arc through cracks in mechanical joints may be underestimated if the

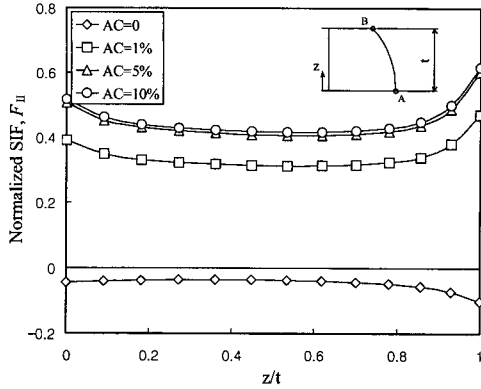

(a) Mode II

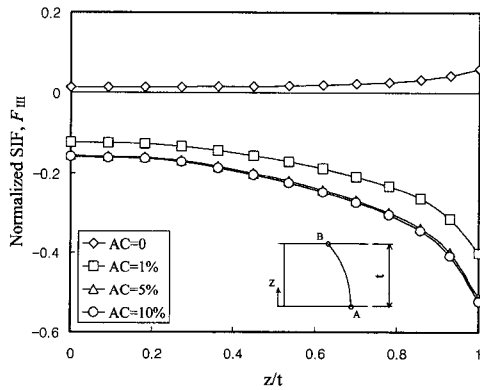

(b) Mode III

**Fig. 17** Mode II and mode III stress intensity factors for elliptical arc through cracks in mechanical joints for different clearance conditions

cases of clearance are treated as an idealized model without clearance.

Figure 17(a), (b) show the mode II and mode III stress intensity factors for elliptical arc through cracks in mechanical joints for  $a/t=1.5$ ,  $a/c_1=0.9$ . It can be seen that the effects of the amount of clearance are almost same as mode I, but the increase in the stress intensity factor as the increase in clearance from 1% to 5% is relatively larger than mode I.

It can also be seen from the figures that the mode II, mode III stress intensity factors in the case of no clearance and of clearance have opposite signs. This fact reveals that the relative deformation of crack surface appears adversely.

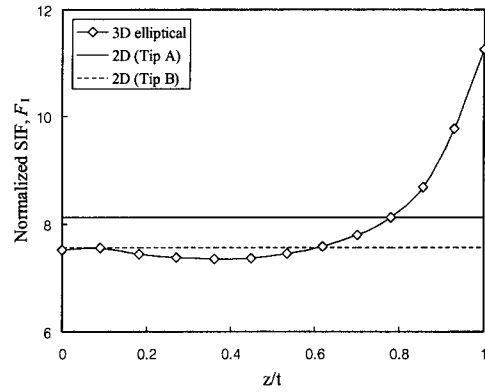

**Fig. 18** Comparison of mode I stress intensity factors for elliptical arc through cracks and two-dimensional cracks in mechanical joints

However, the mode II and mode III stress intensity factors in the case of no clearance are nearly zero. It can thus be concluded that elliptical arc through cracks in mechanical joints are considered as pure mode I in the case of no clearance, but even cracks normal to applied load are mixed-mode condition in the case of clearance.

#### 4.2 Comparison with two-dimensional model

From Fawaz's experimental observations (1998, 1999), cracks in mechanical joints occur as elliptical corner cracks and grow as elliptical arc through cracks after penetrating through the plate thickness. Through-cracks are generally analyzed as two-dimensional crack model. In this study, the analysis results for elliptical arc through crack model were compared with those for two-dimensional through crack model.

Mode I stress intensity factors for elliptical arc through cracks in mechanical joints were analyzed using the virtual crack closure technique and were presented in Fig. 18 with the analysis results for two-dimensional crack corresponding to the length of tip A ( $c_1$ ) and length of tip B ( $c_2$ ). It can be seen that there is not great differences between two-dimensional model and elliptical arc through crack model except near tip B. It can also be known that two-dimensional model with the relatively large length (tip A) is evaluated conservatively and cannot represent the sharp



increase in the stress intensity factor near tip B.

## 5. Conclusions

(1) Three-dimensional finite element analyses were performed for elliptical arc through cracks in mechanical joints constructing non-orthogonal mesh proper to part-elliptical shape. The mixed-mode stress intensity factors were analyzed by the virtual crack closure technique using the finite element results.

(2) The stress intensity factors for elliptical arc through cracks in mechanical joints sharply increase near the surface opposite to crack initiation site and the elliptical front approaches to straight line as crack grows.

(3) Mode I stress intensity factors for elliptical arc through cracks in mechanical joints in the cases of clearance are larger than those of no clearance, but the amount of clearance has little effects on the stress intensity factors.

(4) Elliptical arc through cracks in mechanical joints are considered as pure mode I in the case of no clearance, but even cracks normal to applied load are mixed-mode condition in the case of clearance.

(5) There is not great differences between two-dimensional through crack model and elliptical arc through crack model, but two-dimensional model cannot represent the sharp increase in the stress intensity factor near the surface opposite to crack initiation site.

## Acknowledgements

The authors are grateful for the support provided by a grant from the Korea Science & Engineering Foundation(KOSEF) and Safety and Structural Integrity Research Center at the Sungkyunkwan University.

## References

- Cartwright, D. J. and Parker, A. P., 1982, "Opening Mode Stress Intensity Factor for Cracks in Pin-loads Joints," *International Journal of Fracture*, Vol. 18, No. 1, pp. 65~78.
- Fawaz, S. A., 1998, "Application of the Virtual Crack Closure Technique to Calculate Stress Intensity Factors for Through Cracks with an Elliptical Crack Front," *Engineering Fracture Mechanics*, Vol. 59, No. 3, pp. 327~342.
- Fawaz, S. A., 1999, "Stress Intensity Factor Solutions for Part-elliptical Through Cracks," *Engineering Fracture Mechanics*, Vol. 63, pp. 209~226.
- Heo, S. P. and Yang, W. H., 2001, "Mixed-Mode Stress Intensity Factors and Critical Angles of Cracks in Bolted Joints by Weight Function Method," *Archive of Applied Mechanics*, accepted for publication.
- Ju, S. H., 1997, "Stress Intensity Factors for Cracks in Bolted Joints," *International Journal of Fracture*, Vol. 84, pp. 129~141.
- Lin, X. B. and Smith, R. A., 1999, "Stress Intensity Factors for Corner Cracks Emanating from Fastener Holes under Tension," *Engineering Fracture Mechanics*, Vol. 62, pp. 535~553.
- Narayana, K. B., Dayananda, T. S., Dattaguru, B., Ramamurthy, T. S. and Vijayakumar, K., 1994, "Cracks Emanating from Pin-Loaded Lugs," *Engineering Fracture Mechanics*, Vol. 47, No. 1, pp. 29~38.
- Raju, I. S., 1987, "Calculation of Strain-energy Release Rates with Higher Order and Singular Finite Elements," *Engineering Fracture Mechanics*, Vol. 28, No. 3, pp. 251~274.
- Raju, I. S. and Newman Jr., J. C., 1979, "Stress Intensity Factors for a Wide Range of Semi-elliptical Surface Cracks in Finite-thickness Plates," *Engineering Fracture Mechanics*, Vol. 11, pp. 817~829.
- Raju, I. S., Sistla, R. and Krishnamurthy, T., 1996, "Fracture Mechanics Analyses for Skin-stiffener Debonding," *Engineering Fracture Mechanics*, Vol. 54, No. 3, pp. 371~385.
- Shivakumar, K. N. and Newman Jr., J. C., 1991, "Stress Intensity Factors for Large Aspect Ratio Surface and Corner Cracks at a Semi-circular Notch in a Tension Specimen," *Engineering Fracture Mechanics*, Vol. 38, No. 6, pp. 467~473.
- Shivakumar, K. N., Tan, P. W. and Newman

Jr., J. C., 1988, "A Virtual Crack Closure Technique for Calculating Stress Intensity Factors for Cracked Three Dimensional Bodies,"

*International Journal of Fracture*, Vol. 36, pp. R43~R50.