

# Auxiliary Resonant Commutated Leg Snubber Linked 3-Level 3-Phase Voltage Source Soft-Switching Inverter

Masayoshi Yamamoto\*, Shinji Sato, Eiji Hiraki and Mutsuo Nakaoka

Dept. of Electrical and Electronics Eng., Yamaguchi University, Yamaguchi, 755-8611, Japan

## ABSTRACT

This paper presents a performance analysis in steady-state of a novel type Auxiliary Resonant Commutation Snubber-linked 3-level 3-phase voltage source soft switching inverter suitable and acceptable for high-power applications in comparison with other three types of 3-level 3-phase voltage source soft switching inverters. This soft switching inverter operation which can operate under a condition of Zero Voltage Switching (ZVS). The practical steady-state performances of this inverter are illustrated and evaluated on the basis of the experimental results.

**Keywords:** 3-level 3-phase voltage source inverter, Auxiliary resonant commutated leg snubber, Soft switching, Power loss analysis

## 1. Introduction

In recent years, a variety of 3-phase voltage source inverter and active rectifier using IGBTs or IGCTs, which can operate under a principle of zero voltage or zero current soft commutation transition schemes have been actively studied in order to minimize the switching power losses of power semiconductor devices, their electrical dynamic and peak stresses, voltage and current surge-related EMI/RFI noises under high frequency switching<sup>[1][2]</sup>.

The 3-phase voltage-fed inverters and rectifiers operating under zero voltage soft switching transition PWM modes are roughly divided into 3 types; resonant

AC link and resonant DC link<sup>[3][4]</sup> Auxiliary Resonant Commutated leg Snubber (ARCS) link<sup>[5]-[7]</sup>.

In actual, the 3-phase voltage source soft switching inverters and PFC rectifiers required for utility interactive power supplies and active power filter and static var compensators, which can efficiently operate under a principle of zero voltage soft switching (ZVS) method have been developed so far. However, there have been only a few papers<sup>[9]-[13]</sup> of soft switching power conversion circuits and control techniques for 3-level 3-phase voltage source soft switching inverter and rectifier which are more suitable and acceptable for high power high voltage energy processing systems.

In this paper, the power loss analysis and efficiency calculation simulator for ARCS 3-phase soft switching inverter using IGBTs is presented, which are based on experimental results of power device characteristics. In addition, 3-level 3-phase voltage source soft switching inverter with ARCS circuits are introduced and discussed in terms of the efficiency calculation simulator. And more,

---

Manuscript received April 10, 2002; revised April. 1, 2003.

Corresponding Author :

yamamoto@pe-news1.eee.yamaguchi-u.ac.jp,

Tel : +81-836-85-9472, Fax : +81-836-85-9401

the ARCS circuit which is more suitable for high power applications is presented as compared with the other type of ARCS assisted 3-level 3-phase soft-switching inverter is picked up here-in. Furthermore, the performance of 3-level 3-phase voltage source soft switching inverter with ARCS circuits originally selected here are illustrated and evaluated on the basis of the experimental results.

### 2. Efficiency Calculation Simulator for ARCS 3-Phase Voltage Source Soft Switching Inverter

Fig. 1 illustrates one phase of ARCS assisted 3-phase soft switching inverter. The efficiency calculation simulator of this inverter need 4 data; the resonant inductor resistance component  $R_{Lr}$  ( $R_{Lr}=0.141[\Omega]$ ),  $v-i$  characteristics of IGBT and diode used in ARCS 3-phase voltage source soft-switching inverter (see Fig. 2), the turn off switching power loss characteristics of the IGBT and the diode (see Fig. 3), the output filter resistance ( $R_{Lf}=0.05[\Omega]$ ). From this simulator and operating the hardware system of ARCS 3-phase soft-switching inverter, the comparative output power vs. inverter efficiency performances between experiment and practical simulator

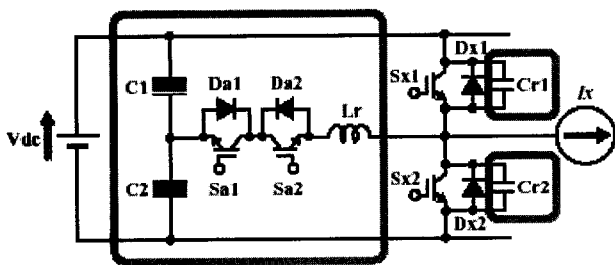

Fig. 1. 3-phase ARCS soft-switching inverter for one-phase part.

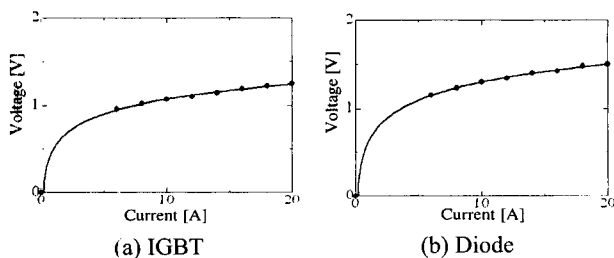

Fig. 2.  $v-i$  characteristics of IGBT and diode.

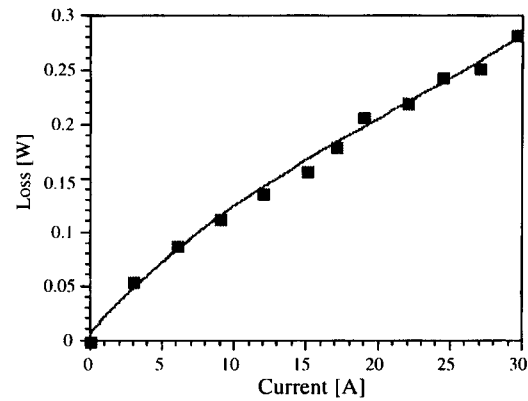

Fig. 3. Turn-off switching loss characteristics.

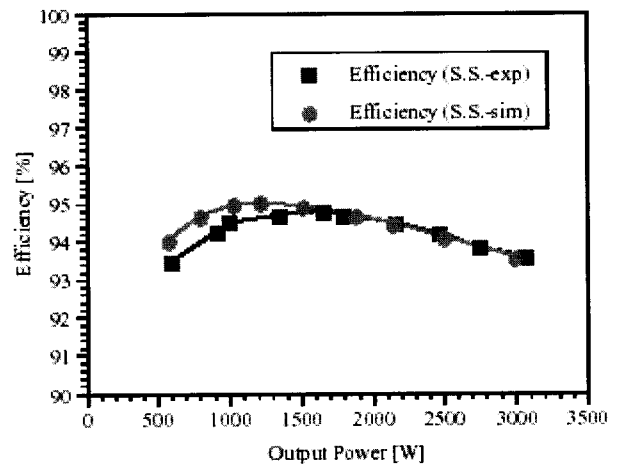

Fig. 4. Power efficiency performance.

are shown in Fig. 4. Observing these results, it is understood that the output power vs. efficiency performance has the same values between experimental and simulation setup.

### 3. 3-Level 3-Phase Voltage Source Soft Switching Inverter Topologies with ARCS Circuits

Fig. 5 shows one bridge leg phase equivalent circuit of 4 types Auxiliary Resonant Commutation leg Snubber linked 3-level 3-phase voltage-fed soft-switching inverter. Each operation of these four types ARCS circuit is briefly described as follows;

#### (Topology A)

This ARCS circuit type consists of the minimum number of components as compared with the other types

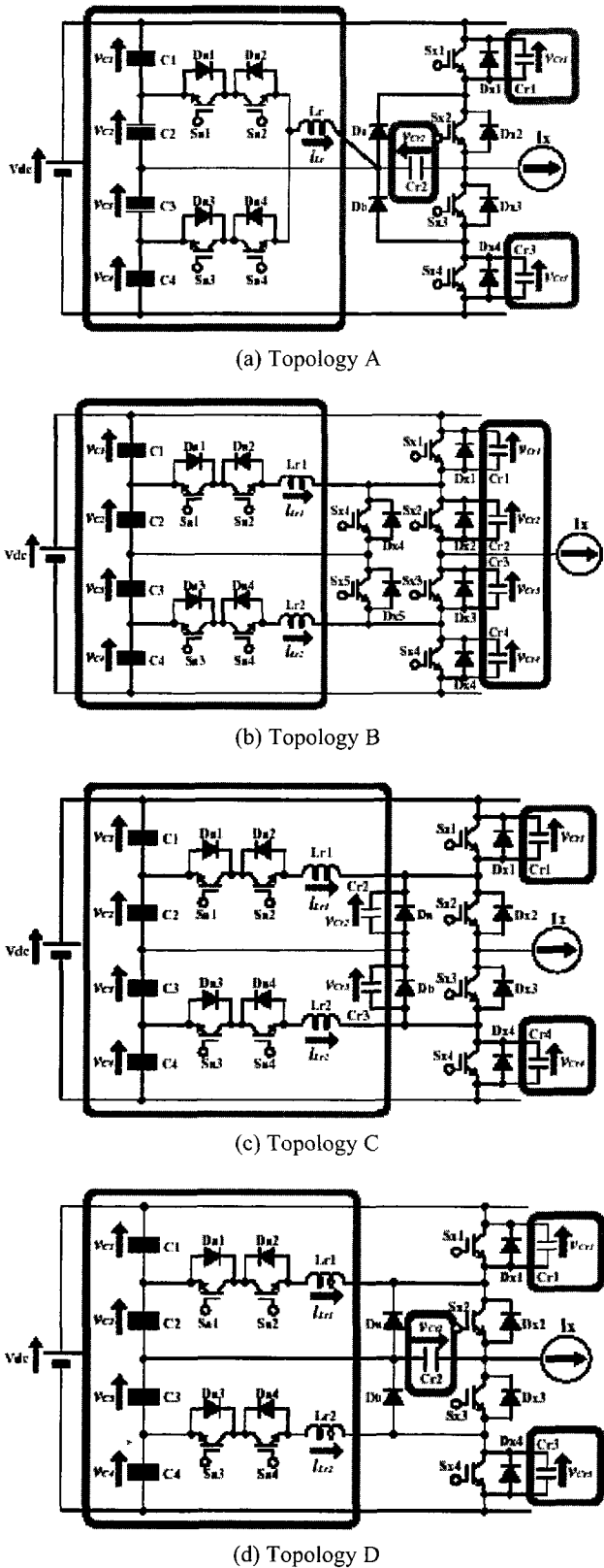

Fig. 5. Several 3-level 3-phase ARCS inverter for one-phase part.

of circuits (Topology B~Topology D). On the other hand, in steady state mode, the additional auxiliary power semiconductor devices (Sa1~Sa4) respectively require 3/4 of DC bus-line voltage in this type. Each voltage value of auxiliary power semiconductor devices in Topology B~Topology D is a half of DC bus-line voltage. As a result, This type of ARCS circuit topology is not more suitable for high voltage applications as compared with the other type of ARCS circuits.

**(Topology B)**

In this type of circuit topology, the voltage across auxiliary active power switches is sufficiently more reduced as compared with that of the Topology A. However, this circuit topology requires two additional power semiconductor switching devices as depicted in Fig. 5. So, it is clear that the configuration using this type of ARCS circuit is not more cost effective than the other types of ARCS circuits because of required additional two IGBTs as compared with those of each topology A, C and D. For this reason, the circuit of Topology B is not selected in this paper.

**(Comparative Efficiency; Topology C and Topology D)**

By using the efficiency calculation simulator, the efficiency in these 3 type soft switching inverters (Topology A, B, C and D) are shown in Table 1. It is proved that each efficiency of these ARCS circuits is almost the same value in spite of the differences of the circuits configurations. From the considerations in cost and efficiency, it could be understood that the efficiency of Topology C is better than those of the other topological types of 3-level 3-phase soft switching inverters.

Table 1. Comparative evaluations on efficiency of 3-level 3-phase voltage Source soft switching inverter.

Circuit Type	Efficiency [%]
Topology A	92.422
Topology B	92.894
Topology C	92.852
Topology D	92.858

### 4. Circuit Description and Operation

#### 4.1 ARCS Circuit Description

Fig. 6 shows one leg phase equivalent circuit of auxiliary resonant commutation-leg snubber (Topology D) linked 3-level 3-phase voltage source soft switching 3-level 3-phase voltage source inverter has basically three

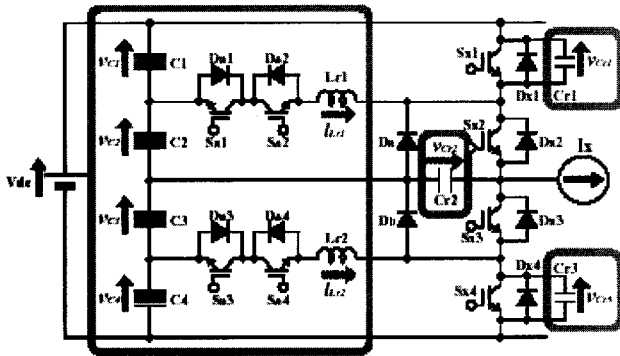

Fig. 6. 3-level 3-phase ARCS inverter for one-phase leg.

inverters using IGBT power modules. As shown in Fig. 7, modes in steady-state operation (State A~State C). The relation between switching state and output phase voltage for 3-level 3-phase voltage source inverter is described in Table 2. To achieve complete ZVS operation, upper side ARCS circuit acts as the transition between State A and State B. On the other hand, lower side ARCS circuit acts as the transition between State B and State C. To illustrate the operating principle of the proposed 3-level 3-phase voltage source soft switching inverter, the commutation mechanism from the State A to the State B is discussed below. For simplicity, some assumptions are considered as follows;

- (1) All the power semiconductor switching devices incorporated into the inverter are ideal.
- (2) Load current equals to the positive  $I_x$  as indicated in Fig. 8 which is kept constant during a short commutation interval because the low pass filter is connected to the output parts of this inverter.

#### 4.2 ARCS Circuit Operation

Fig. 9 represents the typical voltage and current waveforms of the main active power switches and the auxiliary active power switches of this soft-commutation circuit; ARCS circuit shown in Fig. 6. As shown in Fig. 9, there are 10 operation modes. The operating principle in periodic steady-state (in case of this explanation, from State B to State A) can be described as follows:

**State B : mode 0 ( $t < t_0$ )**

The positive load current is freewheeling through  $D_n$  and  $S_{x2}$ , while  $S_{x2}$  and  $S_{x3}$  is on state and  $S_{x1}$  and  $S_{x4}$  is off state (State B).

**State B : mode 1-1( $t_0 - t_1$ )**

The auxiliary switch  $S_{a2}$  is turned on under Zero Current Soft Switching (ZCS) condition. The current through  $D_n$  begins to decrease linearly as the current through the resonant inductor increases linearly.

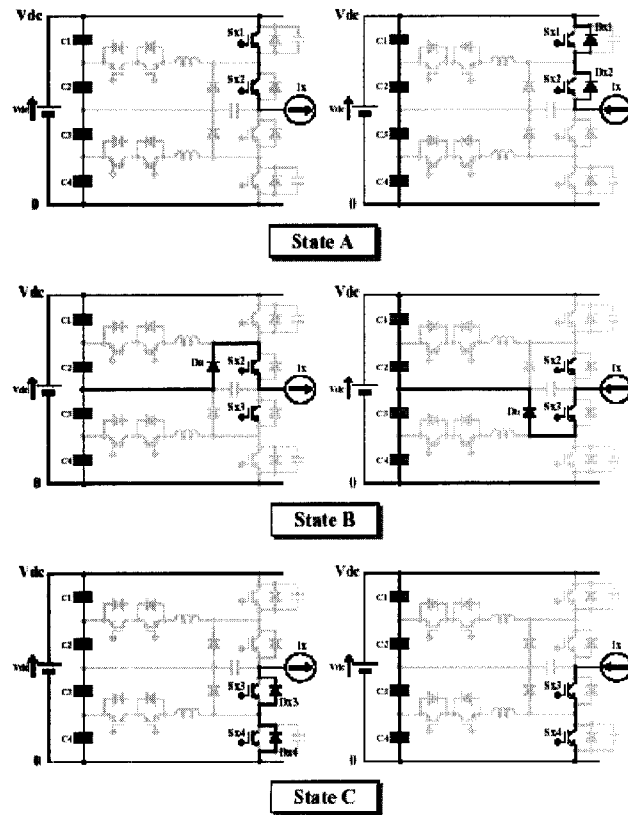

Fig. 7. Circuit state of 3-level voltage source soft switching inverter.

Table 2. Switching state of 3-level voltage source inverter.

State	Switching Sequence States				Output States
	Sx1	Sx2	Sx3	Sx4	
A	ON	ON	OFF	OFF	$V_{dc}$
B	OFF	ON	ON	OFF	$\frac{1}{2} V_{dc}$
C	OFF	OFF	ON	ON	0

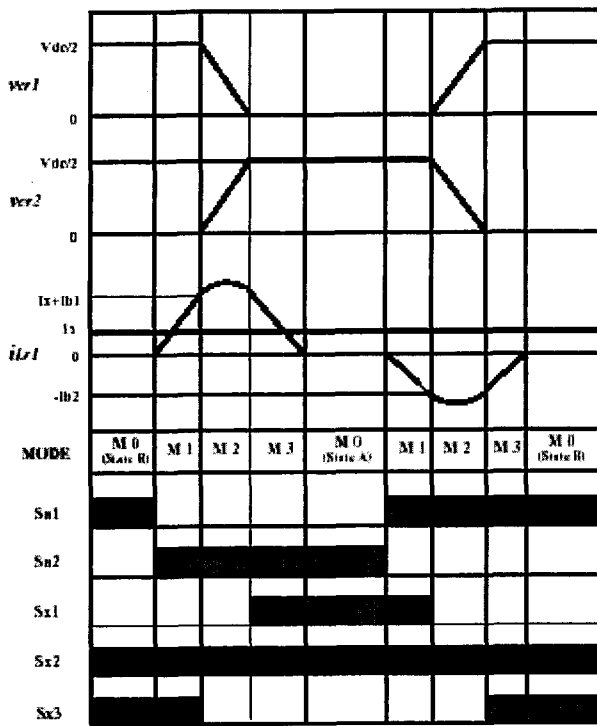

Fig. 8. Gate pulse sequences and waveforms of ARCS circuit.

**State B : mode 1-2( $t_1 - t_2$ )**

At  $t_1$ , the current through  $D_{a1}$  reaches zero, when a resonant inductor current is equal to the load current  $I_x$ . After this condition, the current in  $S_{x3}$  begins to increase. The resonant inductor current becomes greater than the load current, and continues rising until the stored energy is high enough to charge and discharge the resonant capacitors (Boost current).

**State B : mode 2( $t_2 - t_3$ )**

After turning off  $S_{x3}$  with ZVS, the resonant losses capacitor  $C_{r1}$  begins to discharge to zero while the resonant capacitor  $C_{r2}$  begins to charge toward half of dc busline voltage. This provides a resonance between the resonant inductor  $L_{r1}$  and the resonant capacitors  $C_{r1}$  and  $C_{r2}$ .

**State B : mode 3-1( $t_3 - t_4$ )**

At  $t_3$ ,  $D_{x1}$  is conducted and resonant inductor current begins to decrease linearly. On the other hand,  $S_{x1}$  can be turned on at ZVS/ZCS hybrid soft switching condition.

**State B : mode 3-2( $t_4 - t_5$ )**

At  $t_4$ , the current through  $D_{x1}$  is commutated to  $S_{x1}$  and resonant inductor current decreases linearly.

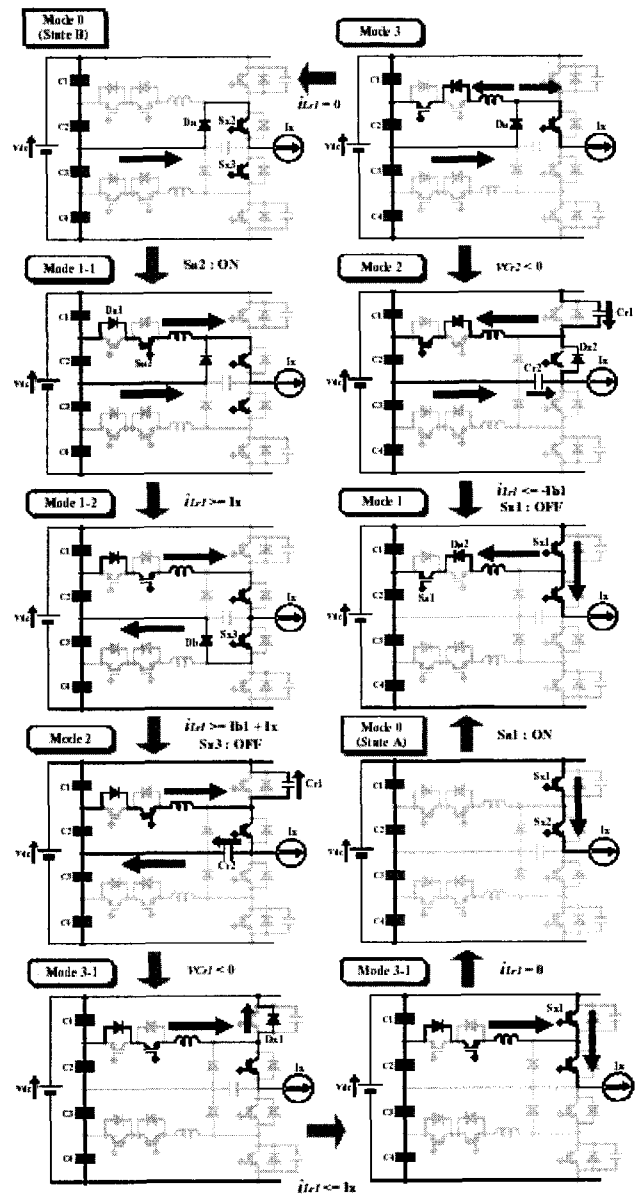

Fig. 9. Equivalent circuits of ARCS circuit and operation mode.

**State A : mode 0( $t_5 - t_6$ )**

At  $t_5$ , the resonant inductor current becomes zero and  $D_{a1}$  is turned off. The load current is totally commutated to  $S_{x1}$  and  $S_{x2}$  (State A).

**State A : mode 1( $t_6 - t_7$ )**

$S_{a1}$  is turned on with a ZCS condition. The resonant inductor current begins to increase toward minus direction linearly and continues to rise until the stored energy is high enough to charge and discharge the resonant capacitors.

**State A : mode 2( $t_7 - t_8$ )**

After turning off  $S_{x1}$  with a ZVS, the resonant capacitor  $C_{r1}$  begins to charge to a half of DC-link voltage while the other resonant capacitor  $C_{r2}$  begins to discharge to zero.

**State A : mode 3( $t > t_8$ )**

At  $t_8$ ,  $D_{a1}$  is conducted and the resonant inductor current begins to decrease toward minus direction linearly. When the resonant inductor current becomes zero,  $D_{a2}$  is turned off and be back to State B - mode 0

## 5. Experimental Results of 3-Level 3-Phase Voltage Source Soft Switching Inverter

### 5.1 Experimental Set up

In order to verify the operating performances of the selected 3-level 3-phase voltage source soft switching inverter, the topology depicted in Fig. 6 is tested under a balanced 3-phase inductive load on the basis of experimental setup. Fig. 10 illustrates the experimental set up of 3-level 3-phase voltage source soft switching inverter using IGBT modules. Table 3 indicates the design specifications and circuit parameters of the 3-level 3-phase soft switching inverter treated here. This new conceptual 3-level 3-phase voltage source soft switching inverter system includes DSP (TMS320C35) control implementation, voltage and current sensors and the divided DC voltage smoothing circuit. The active power switches  $S_1$ ,  $S_2$ ,  $S_3$  and  $S_4$  in the DC side circuit construction operate for stability of divided 4 smoothing capacitors.

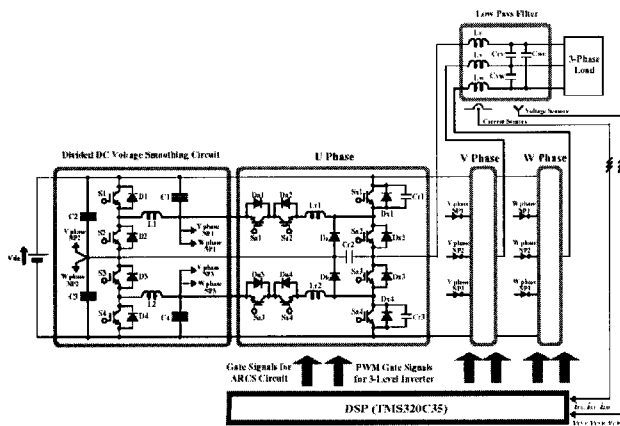

Fig. 10. Experimental setup of 3-level 3-phase voltage source soft-switching inverter.

Table 3. Design specifications and circuit parameters.

Input DC Voltage	: $V_{dc}$	280 [V]
Resonant Inductor	: $L_{rx}$ ( $x=1\sim 2$ )	50.0 [ $\mu$ H]
Resonant Capacitor	: $C_{rx}$ ( $x=1\sim 3$ )	0.022 [ $\mu$ F]
DC Smoothing Capacitor	: $C_x$ ( $x=1\sim 4$ )	8200[F]
Load Resistance	: $R_{uv}=R_{vw}=R_{wu}$	4.0 [ $\Omega$ ]
Load Inductor	: $L_{uv}=L_{vw}=L_{wu}$	4.0 [mH]
Filter Capacitor	: $C_{uv}=C_{vw}=C_{wu}$	65.0 [ $\mu$ F]
Filter Inductor	: $L_x$ ( $x=U,V,W$ )	500 [ $\mu$ H]
Sampling Frequency	: $f_s$	12.8 [kHz]
Output Frequency	: $f_o$	50.0 [Hz]
Switching Frequency of $S_1\sim S_4$	: $f_{sdc}$	20.0 [kHz]

### 5.2 Experimental Results and Discussions

Fig. 11 displays the output voltage and current waveforms obtained from the experimental setup of the 3-level 3-phase voltage source soft switching inverter. The observed resonant inductor current, the current and the voltage across the main active power switch  $S_{u1}$  is shown in Fig. 12. Observing these experimental results, it is clear that the main objectives of the proposed 3-level 3-phase voltage source soft switching inverter system can be achieved in principle and in reality.

Fig. 13 shows the observed voltage and current waveforms at soft switching turn on and turn off for the 3-level 3-phase voltage source inverter main switch  $S_{u1}$  in the bridge arm, as compared with those of the hard switching experimental setup. In case of hard switching, the high  $dv/dt$  voltage and the high frequency current surge are observed because of parasitic circuit and device components in addition to the stray inductance of the wiring. On the other hand, significantly reduced  $dv/dt$  and  $di/dt$  values in soft switching inverter main switches means that EMI/RFI noises can be reduced greatly from Fig. 13.

Furthermore, it is clear that the switching power device power losses of the 3-level 3-phase voltage source soft switching inverter can be remarkably reduced from 117.0 $\mu$ J to 49.8 $\mu$ J because of soft switching operation achieved completely.

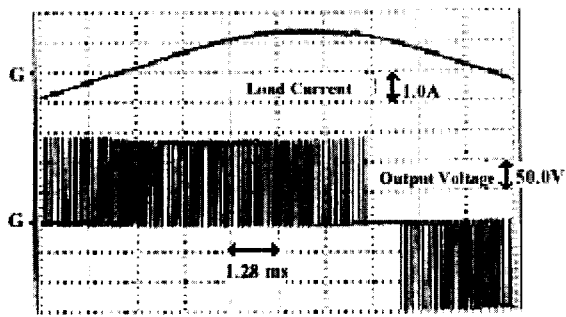

Fig. 11. The output voltage and current waveforms of 3-level 3-phase voltage source soft switching inverter.

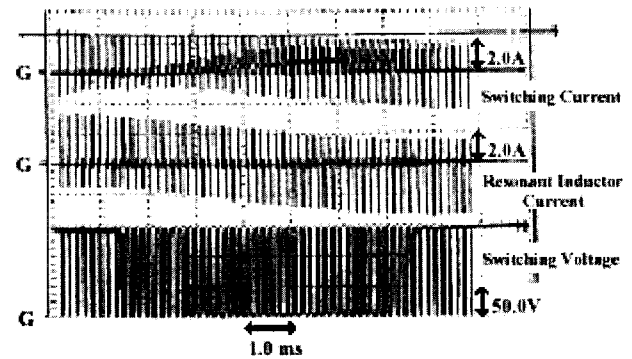
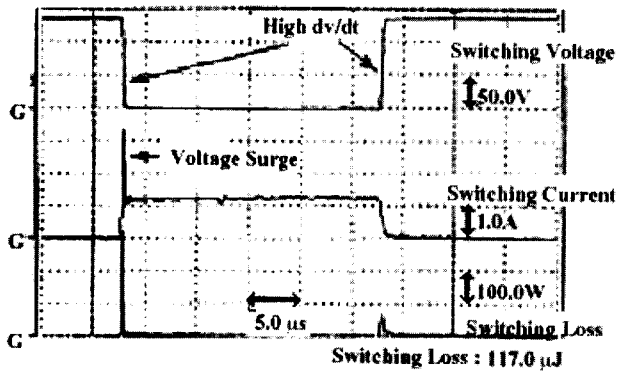
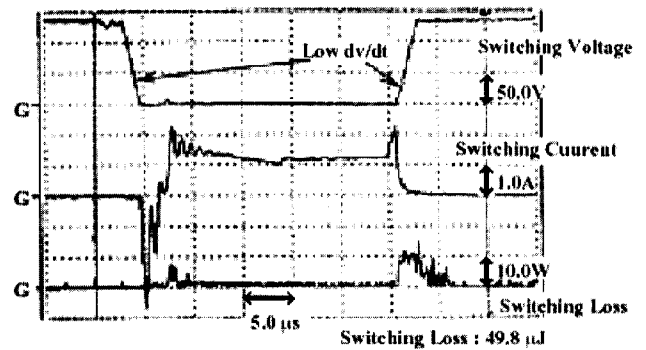

Fig. 12. The resonant inductor current waveforms and voltage and current waveforms across main switch  $S_{u1}$  of 3-level 3-phase voltage source soft switching inverter.



(a) In case of hard switching



(b) In case of soft switching

Fig.13. Switching operating waveforms of main active switch  $S_{u1}$ .

## 6. Conclusions

In this paper, some topologies of active auxiliary resonant commutation leg snubber-based 3-level 3-phase voltage source soft switching inverters have been presented. The comparative evaluations of these inverters have been discussed. This paper have selected the most simple and effective topology of auxiliary resonant commutated leg snubbers-assisted 3-level 3-phase voltage source soft switching inverter by using efficiency calculation simulator constructed here. In addition to this, the operating principle and features of a novel type auxiliary resonant commutated leg snubber assisted 3-level 3-phase voltage source soft switching inverter have been discussed described and discussed. Furthermore, it was proved from an experimental setup that auxiliary

resonant commutation leg snubber linked 3-level 3-phase voltage source soft switching inverter was more cost effective which can efficiently operate under a principle of high performance ZVS in order to minimize switching power losses.

In the future, the comparative feasible studies between active resonant DC link and active resonant commutation arm link associated 3-level 3-phase voltage source soft switching inverters should be developed for high voltage and high power applications such as utility interactive power supplies and active power filter and static var compensators.

The advanced 3-level 3-phase soft-switching inverters and PFC converters using the new power semiconductor switching devices such as Trench Gate PT-IGBTs, IGCTs, High Conductivity IGBTs (HiGTs) and IEGTs should be evaluated from a practical point of view.

## References

- [1] W. MacMurray, "Resonant Snubbers with Auxiliary Switches", IEEE-IAS Conference Records, pp. 829-834, Oct., 1989.
- [2] R. W. De Doncker, "Hard and Soft-Switched Voltage Source Inverters", Tutorial Textbook of IEEE, PESC-Taiwan, June, 1994.
- [3] H. Yonemori, H. Ishii, M. Yoshida and M. Nakaoka "Three-Phase ZVS-PWM Inverter System with Transformer-Assisted Quasi-Resonant DC Link and It's Feasible Comparative Evaluations", Proceedings of IEEE-Power Electronics Specialists Conference (PESC), Vol. 1, pp. 171~176, June 1996.
- [4] Yong C. Jung, Hyo L. Liu, Guk C. Cho and Gyu H. Cho "Soft Switching Space Vector PWM Inverter Using a New Quasi-Parallel Resonant DC Link", Proceedings of IEEE Trans. on Power Electronics, Vol. 1, No. 3, pp. 503~511, May 1996.
- [5] M. Yamamoto, E. Hiraki and M. Nakaoka "Three Phase Voltage-fed Soft Switching PFC Rectifier with an Instantaneous Power Feedback Control Scheme", Proceedings of International Conference on Electrical Engineering (ICEE-Korea), Vol. 1, pp. 202~205, July 1998.
- [6] R. W. DeDoncker and J. P. Lyons, "The Auxiliary Resonant Commutated Pole Converter", Proceedings of International Conference of IEEE-IAS, pp. 1228~1235, 1990.
- [7] S. Bernet, R. Teichmann, J. Weber and P. Steimer, "Evaluation of ARCP Converters with IGBTs", Proceedings of International Conference of IEEE-IAS, 1999.
- [8] R. Teichmann and S. Bernet, "A Multi-Level ARCP Voltage Source Converter Topology", Proceedings of Annual Conference of IEEE Industrial Electronics Society (IECON), Vol. 2, pp. 602~607, Dec., 1999.
- [9] M. Yamamoto, E. Hiraki, H. Iwamoto, S. Sugimoto, I. Kouda and M. Nakaoka, "Voltage-Fed NPC Soft-Switching Inverter with New Space Voltage Vector Modulation Scheme", Records of IEEE Industry Applications Society (IAS), Vol. 2, pp. 1178~1185, Oct., 1999.
- [10] X. Yuan, H. Stemmler and I. Barbi, "Investigation on the Clamping Voltage Self Balancing of the Three-Level Capacitor Clamping Inverter", Proceedings of IEEE-PESC, pp. 1059~1064, 1999.
- [11] J. G. Cho et al., "Three-level Auxiliary Resonant Commutated Pole Inverter for High Power Applications", Proceedings of IEEE-PESC, pp. 1019~1026, 1996.
- [12] X. Yuan, G. Orglmeister and I. Barbi, "ARCPI Resonant Snubber for the Neutral Point Clamped (NPC) Inverter", Proceedings of International Conference of IEEE-IAS, 1999.
- [13] F. R. Dijkhuizen, J. L. Duarte and W. D. H. van Groningen, "Multi-Level Converter with Auxiliary Resonant Commutated Pole", Proceedings of International Conference of IEEE-IAS, pp. 1440~1446, 1998.



**Masayoshi Yamamoto** received his M.S. in Electric and Electrical Engineering from Yamaguchi University, Japan in 2000. He is currently with the Power Electronic System and Control Engineering Laboratory at Yamaguchi University, Japan, as a Ph.D. candidate student. From 2000 to 2003, He was the Research Fellow of the Japan Society for the Promotion Science. His research interests are in the the soft-switching technique for Multi-level converter and rectifier systems. Mr. Yamamoto is a member of IEE-Japan and IEEE-USA.



**Shinji Sato** joined Sanken Electric Co.,Ltd, Japan in 1998. He is currently with the Power Electronic System and Control Engineering Laboratory at Yamaguchi University, Japan, as a Ph.D. candidate research staff. His research interests are in the the power conversion systems for high power applications such as the active power filter and the static var compensator. He got the first paper prize of IEE-Japan Industry Applications Society, August 2002. He is a technical member in semiconductor power conversion professional meeting. Mr. Sato is a member of IEE-Japan and IEEE-USA.

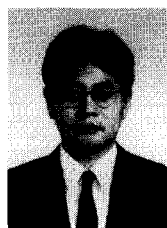

**Eiji Hiraki** received his M.S. in Electrical Engineering from Osaka University, Japan in 1990. He is currently with the Power Electronic System and Control Engineering Laboratory at Yamaguchi University, Japan, as a Research Associate. His research interests are in the soft-switching technique for high frequency switching power conversion systems. Mr. Hiraki is a member of IEE-Japan and IEEE-USA.





**Mutsuo Nakaoka** received his Ph. D. degree in Electrical Engineering from Osaka University, Osaka, Japan in 1981. He joined the Electrical and Electronics Engineering Department of Kobe University, Kobe, Japan in 1981. Since 1995, he has been a professor of the Electrical and Electronics Engineering Department, the Graduate School of Science and Engineering, Yamaguchi University, Yamaguchi, Japan. His research interests include application developments of power electronics circuit and systems. He received the 2001 premium paper award from IEE-UK. Dr. Nakaoka is a member of IEE-Japan, Institute of Electronics, Information and Communication Engineers of Japan, Institute of Illumination Engineering of Japan, European Power Electronics Association, IEE-UK and IEEE-USA.