

# XML 기반의 사이버 강좌관리 시스템

김혜영<sup>†</sup>·김화선<sup>†</sup>·김흥식<sup>††</sup>·김상균<sup>††</sup>·최흥국<sup>†††</sup>

## 요 약

웹의 빠른 발전은 인터넷 기반의 원격 교육 도구들을 급속히 성장시키고 있다. 웹에서는 상호간의 정보를 서로 교환하고 표현할 때 사용자의 브라우저에서 볼 수 있는 HTML(Hyper Text Markup Language)로 제작된다. 하지만, HTML의 구조적 단점은 모든 분야의 데이터를 저장하고 다른 형태의 데이터로 변환될 수 있는 강한 힘을 지닌 XML(eXtensible Markup Language)을 필요로 하게 되었다. 그러나 강력한 XML 자체만으로 장점을 활용하여 어렵기 때문에 관련 XML표준의 적절한 응용이 필요하다. 현재 사이버 교육 사이트들의 강좌데이터는 서로 공유될 수 없으므로 사용자들은 사이버스쿨이 제공하는 기능만을 수동적으로 사용하기만 해야한다. 이 한계를 해결할 수 있는 방법으로서, 본 연구에서는 사이버 강좌관리 시스템을 위해 통일된 XML데이터 구조를 정의하고 서버와 클라이언트의 처리되는 모델을 제시하였다. 웹에서의 가상 교육에 대한 데이터를 XML로 저장함으로써 한번 저장된 데이터를 어떤 사이트에서도 조금의 수정없이 재 사용할 수 있게 되었다. 사용자적인 측면에서, 교수자와 학습자를 두어 어떤 종류의 사이버강좌라도 쉽게 관리할 수 있고 다양한 멀티미디어 자료와 쉬운 사용자 인터페이스를 제공하여 많은 학습자료들을 효과적으로 관리할 수 있게 되었다. 이는 웹에서의 사이버교육과 관련한 데이터를 효율적인 정보의 교환과 공유를 통해 XML형태로 저장하고 추출함으로써 가능하게 되었고 정보활용에 극대화를 가져올 것이다.

## Cyber-Lecture Management System based on XML

Hye-Young Kim<sup>†</sup>·Hwa-Sun Kim<sup>†</sup>·Heung-Sik Kim<sup>††</sup>  
Sang-Gyun Kim<sup>††</sup>·Heung-Kook Choi<sup>†††</sup>

## ABSTRACT

The speedy development of the world-wide web is rapidly growing the internet-based tools for the remote instruction. In interchanging and expressing the information of one another on the web, it is produced through the form of HTML (HyperText Markup Language). However, the structural disadvantage of the HTML is becoming to require a powerful XML (eXtensible Markup Language) which can store all the sphere of data, and transform them into another form. Nevertheless, because the powerful XML alone cannot make the most of those merits, it is necessary that XML standard should be applied appropriately. Because existing lecture data of cyber education sites cannot be shared, the users should passively use only the functions offered by cyber school. To solve the problem of this limit, in this study, the standardized data structure for XML is defined, and system model for processing between the server and the client is provided. By storing the lecture data of cyber education sites as XML on the web, stored data came to be reused without changing on any site. In the view of Users, they could use the Internet service with equipment that they want at any place and any time. To control any kinds of CLMS (Cyber Lecture Management System) for Administrator and Users, we offered a variety of Multimedia applications and an easy interface and built a new style of CLMS. Therefore, by storing and extracting the data related with the virtual education of the secondary school through the form of XML, for the effective interchange and sharing of the information, maximum utilization of the information can be achieved.

키워드 : XML, 사이버 강좌 관리시스템(Cyber Lecture Management System), XML SPY5.0, Visio2002

### 1. Introduction

The emergence of the web on the internet activated the education through the web. This education system has over-

come the shortcomings caused by time and dimension. However, because the virtual education system was used as presentational purpose implemented through HTML, disadvantages both in utilization and expression of information were pointed out. In order to make up through using extensibility for the weak points of HTML displaying mere information, to solve complicatedness, and to exclude the extensive grammatical structure of SGML (Standard Generalized Markup language), W3C (the World-Wide Web Consortium) adopted XML as a standard on the data exchange for the

\* The authors gratefully acknowledge the support of Medical Image Technology Laboratory (MITL) staff and School of Computer Engineering, Inje University, Korea. This study was supported by a grant of the Korea Health 21 R&D Project, Ministry of Health & Welfare, Republic of Korea (02-PJ1-PG3-20001-0003).

† 준회원 : 인제대학교 대학원 전산학과  
‡ 종신회원 : 인제대학교 정보컴퓨터공학부 교수

†† 정회원 : 인제대학교 정보컴퓨터공학부 교수  
††† 논문접수 : 2003년 7월 22일, 심사완료 : 2003년 10월 10일

next generation [1]. As XML expresses, transfers, and processes educational materials standardized on the web, and transforms existing database materials into XML-based standard, it reveals high effectiveness in the reusability of information. This may be a useful suggestion for the recently increasing data of the information society. As a meta-language, XML is requiring the definition of element tag and attribute, and style sheet determining each of the form of the abstract element. That is, the strong data structure of XML cannot be employed with XML alone. Therefore the various standards in relation are adopted.

Taking a look at the present condition of remote education at home, EDUNET (<http://www.edunet4u.net>), as an integrated education service, is the representative one:

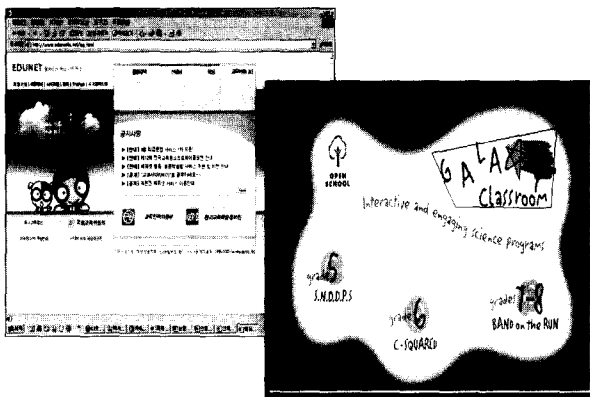

(Figure 1) Edunet4u.net and Galaxy Classroom

In addition, while training of the teachers is being joined in the education through the web, the efforts of both building an effective transmission of the educational information and mutually connecting the dispersed education-related information are being made [2]. Taking examples abroad, there are, in the innovation of education in America, the cases of the adoption of ELSS (Electronic Learning Support System) based on the PC applying multimedia, and the Galaxy Classroom for providing school children in their fifth grade with the exciting educational experience. In this way the fact that the development of cyber-education system is growing explains that there exists a tremendous advantage of high-quality educational information of which all the people including the educational administrators, parents and others can make use [3]. Contrarily, there exists also a disadvantages like the lack of the grasping the attitude and the immediate circumstance of the participants of the education. That is, it is difficult to obtain the appropriate feedback and the continuous maintenance.

Currently in the cases of EDUNET and remote training of teachers, many efforts are being made to provide the functions of managing and controlling the learners and the educational process. And in the case of America, they are taking the lead in the active use of the training of instruction members and the information service by concentrating efforts in the remote education overcoming the time and the dimension by employing an advanced scientific equipment such as the Global Lab, a network laboratory, so called EcoNet, with which students and scientists around the world can transmit messages and communicate with each other.

Thus this thesis suggests a Cyber-Lecture Management System based on XML aiming at an effective system in which maintains the unity and the consistency in reusing or reprocessing lecture data. The chapter 2 deals with the related study for the understanding of XML, the chapter 3 and 4, the designing and implementation of the lecture management which is to be realized on the web in order to provide the elements required in the structural documents, and the chapter 5 the comparison, and finally the chapter, the conclusion together with the future tasks.

## 2. Introducing of the Technique

### 2.1 XML Standard Technique

The W3C designated XML as the standard for the next-generation web-documents in 1998. XML is essentially a language describing another language, that is, a meta-language. XML separates the structure of the document into three parts : the part defining the structure of the document, the form of the expressing document, and the composition of the document. Thus it is important to composing the frame of the document, and DTD solves this. However, because of the weak point that the validation of the data provided through the limited data type is impossible, the Schema was emerged as a new standard [9].

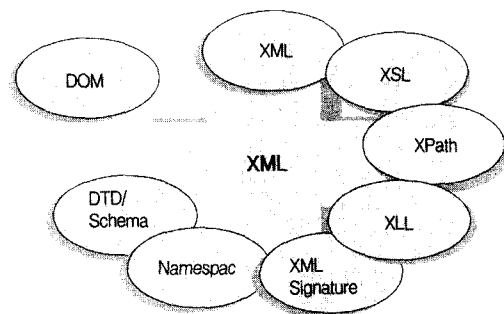

(Figure 2) Standard Concerning XML

Furthermore, XSL (eXtensible Style-sheet Language), XSLT (XSL Transformations) and others through which transforms and transmits the mere XML documents suited to the environment of the user are considered as the related standards. Here the XSLT processor shares XPATH which applies XSL to XML and with the result creates trees and can read the desired contents using query. XPATH (XML Path Language) provides the structural addressing mechanism for XSLT and the elements of the XPointer-based XML documents [1, 4]. (Figure 3) is expressing the XML standard techniques mentioned above and the object-oriented database storage which easily holds the meta-data of the XML document form was added. This indicates that the stored XML is shown through the web interface employing XSL, and the tasks are easily carried out through XQL (XML Query Language) [4].

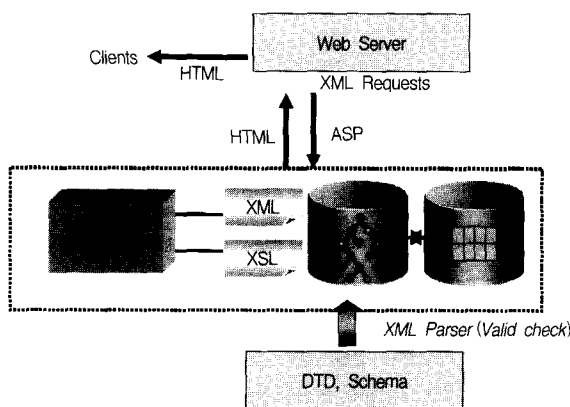

(Figure 3) XML Standard Technique and DataBase[10]

## 2.2 Operation Between ASP and DataBase

ASP (Active Server Page) is a page carrying a dynamic web document, and is a solution based on ISAPI which is supported on the IIS (Internet Information Server) in Win

dows NT and Windows 2000, and PWS (personal Web Server) in Windows 95/98. In the linkage between ASP and Database, when the user query reaches the web server by the web browser, the ASP of the server transfers this to the database engine by using SQL. In order to perform this, ASP uses ADO (ActiveX Data Object) through ODBC. That is, within the components of the ADO objects, the database is processed by using Connection object, Command object and Recordset object [5]. (Figure 4) below is a diagram of the principle which ASP is activated on the web.

## 3. Designing of the System

This chapter explains the designing and implementation of the web applications which enable the composition of the XML documents on the web, and the real-time storage and search into the database, based on the system analysis and grasping of the task.

### 3.1 Selection of the Tools

As this system is a web-based client-server system, it is composed of the lecture, test, and grade. By sharing the lecture data through the internet, the reusability of the data can be maximized. Also this system is based on XML, and by standardizing the structure of the lecture data, this can be applied to the other sites, and the sharing of the data between the sites is made possible. About the system-wide requirement, the server platform is Windows 2000, and on the base of NT or above server, IIS 5.0 was adopted. Web Browser version is above 5.5.

For the development, ASP, for the implementation of the interface between the web-server and the user, MSXML 4.0 for XML Parser, and XMLSPY 5.0, Visio2002 for the authoring tool for this purpose were used.

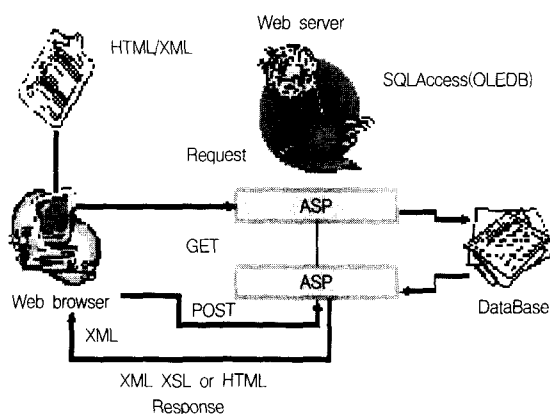

(Figure 4) ASP Execution Principle

### 3.2 Procedure of the Process

In order to store the XML documents on the database, the process of transforming DTD or Schema database into the table must be carried out. Then, after designing the XML storage, Cyber Lecture Management, and the user interface, finishing the test for each unit, overall tests were performed.

#### 3.2.1 XML Schema/DTD

The DTD/Schema defining the structure of the document was designed on the condition that when developing the lecture management program, all the necessary components should be included.

Here, the well-defined DTD or Schema can not only verify the validity of the document but also becomes the basic structure of the application development. That is, by defining a consistent structure, the diverse information on the internet is reused and reprocessed regardless of the location and the time.

On <Table 2>, Members.xsd file is XML Schema which is adopted for the management of the members on the Cyber Lecture within the XML standard techniques. <Table 1> represents DTD, and indicates that the each member element within the biggest element carries child element.

Here one member means one number of memberships. Furthermore, a member contains the attribute of the membership (such as Name, UserID, Password, Year, Month, Day, Email, Address, Tel1, Tel2, Tel3, Grade, and Class). Each attribute takes PCDATA as a value which represents a general character-line in XML. However, the DTD in <Table 1> can not verify the data with its limited data type, and has its weak points in the notation and the repeated designation of the count of the data type.

<Table 1> Member.DTD

```
<?xml version = "1.0" encoding = "UTF-8"?>
<!ELEMENT Members (Member+)>
<!ELEMENT Member (
    Name, UserID, Password, Year, Month, Email, Address,
    Tel1, Tel2, Tel3, Grade, Class )>
<!ATTLIST Member id ID #REQUIRED>
<!ELEMENT Name (#PCDATA)>
<!ELEMENT UserID (#PCDATA)>
<!ELEMENT Password (#PCDATA)>
<!ELEMENT Year (#PCDATA)>
<!ELEMENT Month (#PCDATA)>
<!ELEMENT Email (#PCDATA)>
<!ELEMENT Address (#PCDATA)>
<!ELEMENT Tel1 (#PCDATA)>
<!ELEMENT Tel2 (#PCDATA)>
<!ELEMENT Tel3 (#PCDATA)>
<!ELEMENT Grade (#PCDATA)>
```

Here one member means one number of memberships. Furthermore, a member contains the attribute of the membership (such as Name, UserID, Password, Year, Month, Day, Email, Address, Tel1, Tel2, Tel3, Grade, and Class). Each attribute takes PCDATA as a value which represents a general character-line in XML. However, the DTD in <Table 1> can not verify the data with its limited data type, and has its weak points in the notation and the repeated designation of the count of the data type [9].

Meanwhile, the XML Schema on <Table 2> is currently taking hold as a standard, because it keeps XML formula,

and is free in the ways of designating the number of count and others. This study also designed Members.XSD with the new standard, Schema.

<Table 2> Member.XSD

```
<?xml version = "1.0" encoding = "UTF-8"?>
<xs:schema xmlns:xs = "http://www.w3.org/2001/XMLSchema"
    elementFormDefault = "qualified">
    <xs:element name = "Members">
        <xs:complexType>
            <xs:sequence>
                <xs:element name = "Member"
                    maxOccurs = "unbounded">
                    <xs:complexType>
                        <xs:sequence>
                            <xs:element name = "Name" type = "xs:string"/>
                            .....
                            <xs:element name = "Grade" type = "xs:string"/>
                            <xs:element name = "Class">
                                <xs:complexType>
                                    </xs:element>
                                </xs:sequence>
                            </xs:complexType?>
                        </xs:element>
                    </xs:sequence>
                </xs:complexType?>
            </xs:element>
        </xs:schema>
```

3.2.2 Designing of DataBase

This system as data layer is built upon SQL2000 server, a relative database. This is based on the previously designed XML Schema, a database Schema becomes a relative table. This can be transformed into XML-only database as well as the object-oriented database [5]. Also, as is seen in (Figure 2), this has an additional function with which either from the relative form or object form database can be transformed into the opposite data. Because there are still many users who are using the relative database, and the constant improvement is being made in order to secure the users concerned about XML, this is satisfying the taste of the users.

In this study, the Cyber Lecture Management System uses the total five database tables and the three XML documents. And each data is stored on the different files because if all are stored on one file, there can be much overload while loading XML files using DOM.

As DOM is very important standard and provides the common resources when the document is processed, even if various languages are used, if the DOM standard should be observed, the identical method is used. That is, like (Figure 5), by using DOM, the document is produced, the structures of the element or attribute are searched, and addition, deletion or modification is performed [6]. (Figure 6) below shows the database tables used at the sites and each table stores test data for the lecture and the result record of the test.

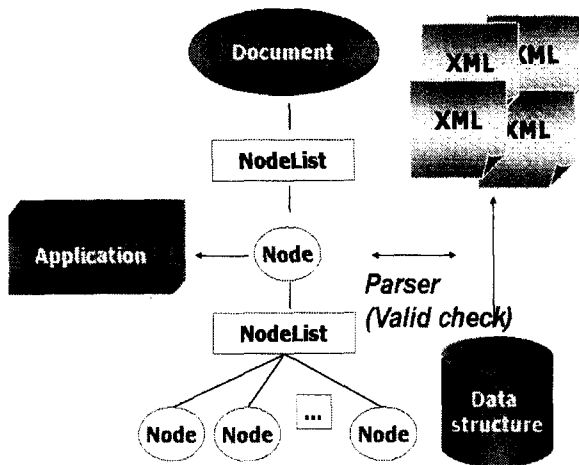

(Figure 5) DOM and Parser

LECTURE		TESTHISTORY		TEST ITEM	
PK, 11	LECTURE_ID	PK, 13	TESTHISTORY_ID	PK, 12	TEST_ITEM_ID
	LECTURE_DESC LECTURE_DATE	11 12 14	TEST_ID TEST_ITEM_ID USERID USER_REPLY	11	TEST_ID CONTENT REPLY1 REPLY2 REPLY3 REPLY_COUNT TEST_ITEM_TYPC PREVIOUS_CONTENT CASE1 CASE2 CASE3 CASE4 CASES POINT
PK, 11	POINT_ID	PK, 13	TEST_ID		
12	TEST_ID POINT TESTING_DATE USERID	FK1, 2, 11	TITLE LECTURE_ID CHAPTER_ID TEST_TYPE READCOUNT START_DATE ISSUE ISDELETE		

(Figure 6) Database Table of Lecture Management System

Meanwhile, the course of processing XML requires the course of mapping element and attribute to the fields of the table. In this time, when saving the XML document, DOM is used internally, and this is used by the ASP page while loading XML document. That is, ASP page, after loading the given XML files using DOM, takes the role of addition, modification and deletion. One XML data is printed out on the browser in the form of HTML by the one or more XSL kept by one XML document when the ASP page returns data to the client [5, 7].

As XML document contains by stages the components retaining the contents and characteristics, this suits best in expressing the step-by-step modeling, that is, the basic conceptual content of the module including the structure of the modular. This probes the well-formedness and validity by XML parser, and composes DOM Tree by parsing XML data.

DOM, like (Figure 5), can add, delete or modify all the elements within the DOM Tree composed as interface. In the case of DTD or Schema, they stores the structure of

XML document, and sprinkles the results to the clients through applying XSL to XML by using DOM within the ASP pages.

<Table 3> is a part of the ASP pages in the Lecture system in which prints on the browser by applying XSL to the given XML document (board.xml).

The result obtained by this code is like (Figure 7). There exist two screens, and the different screens are because the two different XSLs were applied on the one XML document. The first one was applied the style-sheet list.xsl to board.xml, and the second one, view\_form.xsl to board.xml, so revealed the advantage of the XML which overcame the non-reusability of HTML.

<Table 3> Part of ASP page code

```

Set objDoc =
Server.CreateObject ("MSXML2.DOMDocument")
Set objXSL =
Server.CreateObject ("MSXML2.DOMDocument")
strPath = server.MapPath ("Board.xml")
strXSLPath = server.MapPath ("list.xsl")
objDoc.async = false
objDoc.load (strPath)
objXSL.async = false
objXSL.load (strXSLPath)
Response.write objDoc.transformNode (objXSL)
    
```

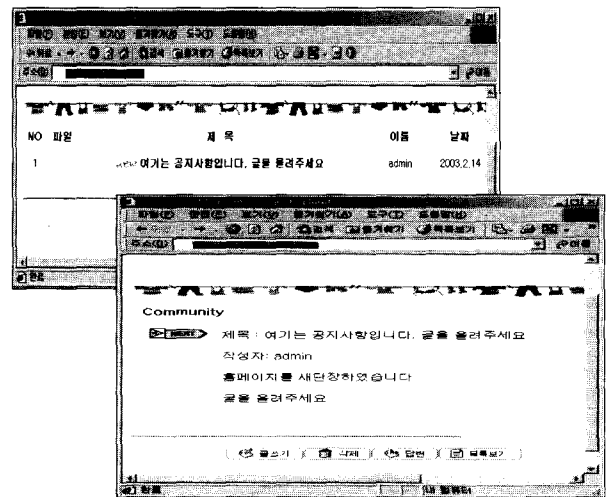

(Figure 7) Bulletin Board using two types of XSL

Here, while XSL is a representative technique of XML which is composed of the part, XSL formatting object, defining the mere output and of the part, XSLT, defining the rules transformed into the form as the user desires, XSLT is employed not only in the transformation between the standards but in the optimizing techniques of the terminals on the wireless internet. On the other hand, the whole structure

of the system is appeared on (Figure 8). The structures are that when the client web browser demands a specific ASP file, the web server loads the ASP page matching this request, and when this ASP page operates with XML document, XML data is processed by using DOM, and when the database operates, the database is processed by using ADO [7].

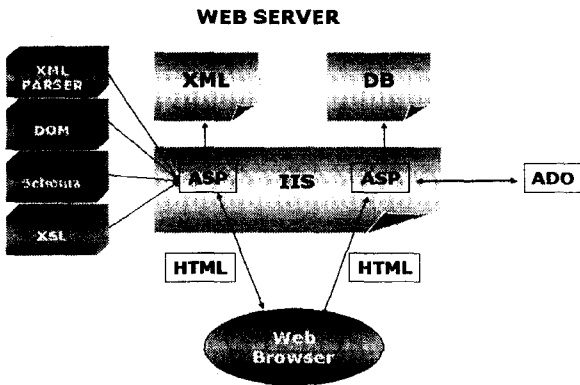

(Figure 8) Configuration of the Whole System

3.3 System Analysis

In the first place, the system was analyzed in order to know the user's demands and structural elements. That is, the authority has to be distributed in a way which is appropriate to the relevant demands by separating the user mode and administrator mode. This is because the role of the user and that of the administrator is different. Therefore, the distinction of the user and the administrator should be clear. In particular, what the user can do is that there exists a business which should be done in the position of the administrator, and that the user should not access the business allotted only to the administrator. Also in the general bulletin board, the notice work should be confined to the administrator only. The administrator only can do the important items like uploading of the lecture, the test and the evaluating

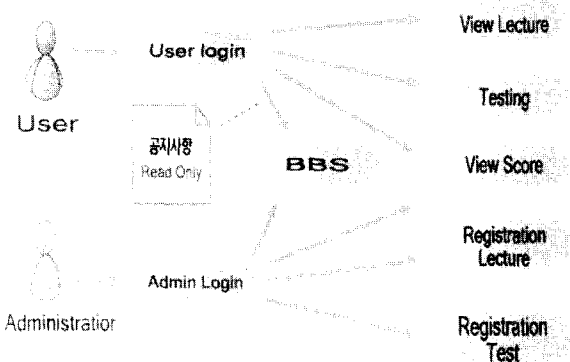

(Figure 9) Usecase diagram

the test. The users can only read the texts, post the messages excluding the notices, and take lectures, take the examinations listed. <Figure 9> shows the diagram made by Visio2000 in the user's side for the creation of the document, in which the object can be deduced and the analysis of the message stream among the objects.

For verification of the sources to utilize the systematic study of Food education and the suitability of Cyber Lecture Management System, the contents must be built to apply to the food education in high school class (Figure 10).

And also, (Figure 11) is a modeling which was transformed into XML Schema from DTD for which the validity test was finished for the purpose of the data linkage by using Spy ver. 5.0.

Because the XML Schema, not like DTD, is containing in itself the rules for the validity verification, they are automatically provided in the phase of the mutual verification between the XML document and DTD regardless of probing the data type or various kinds of rules.

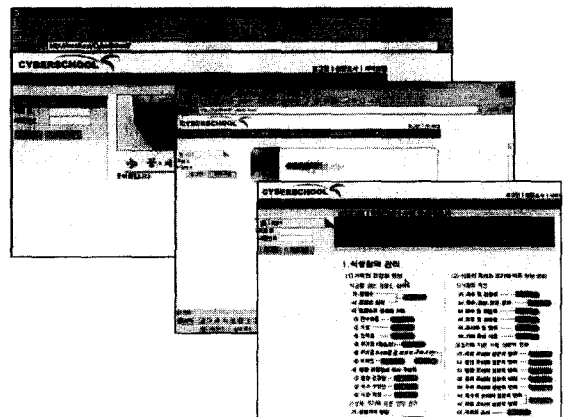

(Figure 10) Contents of the Lecture data

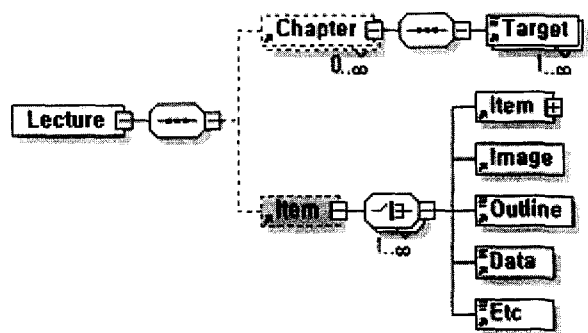

(Figure 11) Schema Modeling of the Data Operation

3.4 Activity Diagram The Whole System

The whole system of the cyber-school was displayed with

Activity Diagram (Figure 12) [11].

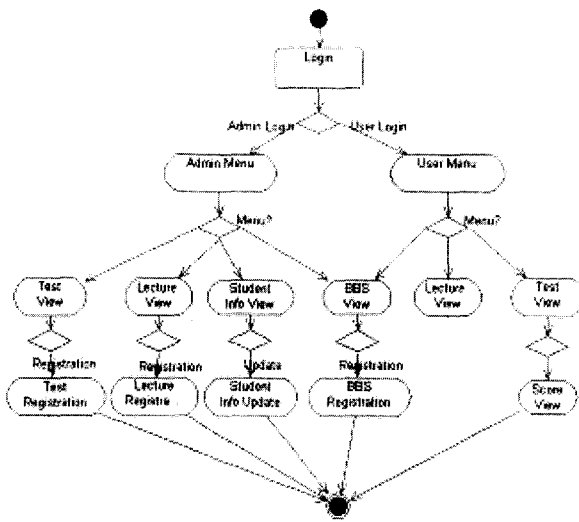

(Figure 12) Activity Diagram

#### 4. Implementation of the Cyber Lecture Management System

The first thing to be done before the implementation of the lecture system is defining the XML document over lecture data. The Lecture.xml with the Lecture data contains Lecture.dtd which defines data structure. From here, one or more XML files, applied by Lecture.xml through XML-processing interface supplied by DOM, are output with a certain form. The child chapter element of the Lecture has data about one Lecture. This data type is composed of FILE, URL, MOV, and TEXT. This type is contained in the ContentType which is a property of the chapter. Both URL and FILE are link to the lecture data, but the difference is that while URL is pointing to a certain web page, FILE is storing itself in the hardware of a site. The lecture data of the FILE type is printed out on the screen as it is, but MOV is printed after passing the process of transforming into the video.

The lecture data of the TEXT type is completely different from the above three types. TEXT type takes the form which the administrator directly saves the lecture data in the XML document.

Only the link data of FILE, URL, and MOV above are stored on XML, but the lecture data, not in the same place as XML, is stored on a different physical location. The XML document on the following <Table 4> <Table 5> shows that the first chapter on the first lecture is lecture data of FILE type, the second chapter is lecture data of URL type, and the third chapter is lecture data of TEXT type.

<Table 4> Lecture data DTD

```
<?xml version = "1.0" encoding = "UTF-8"?>
<!ELEMENT Chapter (#PCDATA | Target)+>
<!ATTLIST Chapter
  ChapterID ID #REQUIRED
  Title CDATA #REQUIRED
  ReadCount CDATA #REQUIRED
  StartDate CDATA #REQUIRED
>
<!ELEMENT Data (#PCDATA)>
<!ELEMENT Etc (#PCDATA)>
<!ELEMENT Image EMPTY
<!ATTLIST Image
  FilePath CDATA #REQUIRED
>
<!ELEMENT Item (Item | Image | outline | Data | Etc)+>
<!ATTLIST Item
  Index CDATA #REQUIRED
  ChapterID CDATA #REQUIRED
  Name CDATA #REQUIRED
  FirstWord CDATA #REQUIRED
>
<!ELEMENT Lecture (Chapter+, Item)>
<!ATTLIST Lecture
  Id ID #REQUIRED
  Title CDATA #REQUIRED
  MakeDate CDATA #REQUIRED
  Makeer CDATA #REQUIRED
  Type CDATA #REQUIRED
>
<!ELEMENT Lectures (#PCDATA)>
<!ELEMENT Outline (#PCDATA)>
<!ELEMENT Target (#PCDATA)>
```

The XML document on <Table 5>, through the XML Schema, while being verified as structurally proper, through XSL which is style-sheet, is implemented on the web browser.

<Table 5> XML Document of Lecture data

```
<?xml version = "1.0" encoding = "euc-kr"?>
<?xml-stYLESHEET type = "text/xsl" href = "Lecture.xsd"?>
<!DOCTYPE Lectures SYSTEM "C:\inetpub\wwwroot
  \CyberSchool\Lecture\Lecture.dtd">
<Lectures>
  <Lecture id = "LECTURE1" Title = "식생활관리"
    MakeDate = "2002-10-27 PM 7 : 27 : 17"
    Maker = "CyberSchool" Type = "TEXT">
    <Chapter ChapterID = "CHAPTER1"
      Title = "균형있는 영양소 섭취"
      ReadCount = "0"
      StartDate = "2002-10-07">
      <Chapter ChapterID = "CHAPTER2"
        Title = "생애 주기에 따른 영양 관리"
        ReadCount = "0" StartDate = "2002-10-14">
        <TEXTContent>
          <Target> 균형있는 식사 </Target>
          <Content/>
        </Chapter>
      </Chapter>
    </Lecture>
  </Lectures>
```

Clicking the wanted or interested chapter, the actual lecture can be viewed. In this course, the complicatedness of the relations were expressed by using UseCase Diagram (Figure 13) adopting the visual modeling [12].

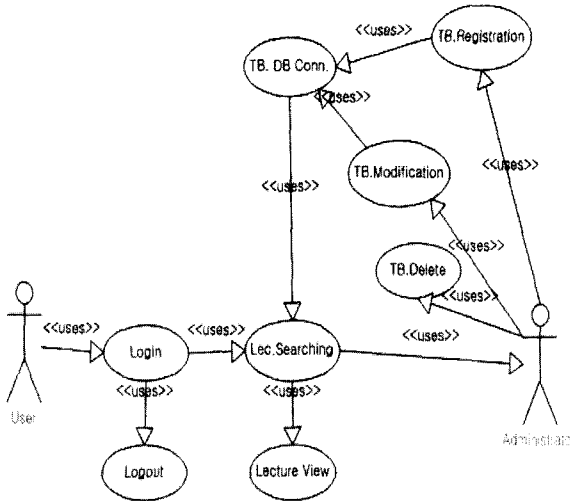

(Figure 13) Lecture Usecase Diagram

4.1 Lecture data Management

Lecture data is the position which contains a new material : a multimedia contents consisting of a various images, audios, animations etc. is made. Textbook number and title are printed automatically a restored contents on a database and Cyber Lecture Management System is supposed to work when a person clicks an image (Figure 14).

NO	Title	시작일	조회수
1	VAML	2003-03-21	0
2	Advance Network	2003-03-21	0
3	FOOD Nutrition	2003-03-21	0
4	홈페이지구성	2003-02-07	0

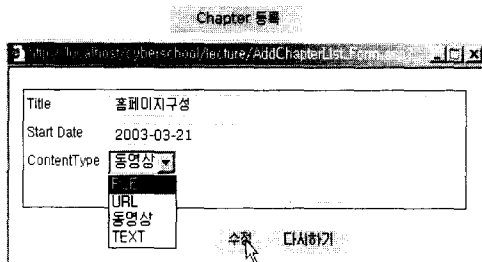

(Figure 14) Lecture Register, Modify, Delete

4.2 Testing Management

It is easy for users to have access to the system with web browsers, confirm the evaluation in the real time, and choose the type of the examinations what they want. Those results of the databasing can help the future education and pre or

post inspection on the result of survey can help to determine the effectiveness of the system (Figure 15) (Figure 16). learners can compared with providing answer feedback and in the case of a wrong answer it can provide a wrong answer feedback immediately

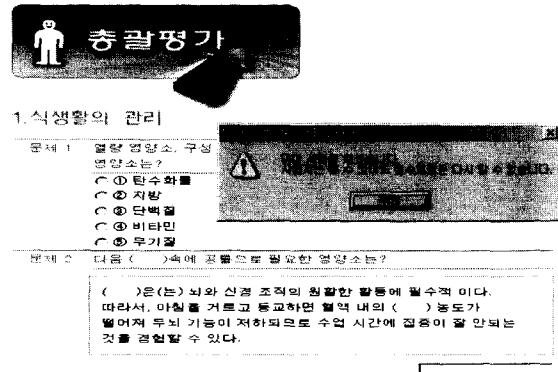

(Figure 15) Test viewing

NO	Title	시작일	조회수
1	식생활의 관리 중간평가	2002-10-29	0
2	식생활의 관리 기말평가	2002-11-24	0
3	이론	2003-07-20	0

(Figure 16) Chapter selecting & Testing result

5. Comparison of the System

In the existing lecture sites on the web, there are lecture data in their own way. Most of the data are stored on the certain tables of the DBMS systems such as Oracle, MSSQL, My SQL, Sybase (Figure 17). They are providing the lectures to the users through transforming the data into the form of HTML by using the sever-side scripts of ASP, JSP, and PHP and sending them to the browser. In the XML system, DTD or Schema is located on the outside, not in the lecture sites in which XML and XSL reside (Figure 18).

In other words, the definition for the lecture data is specified by another standard enterprise. DOM loads XML and XSL located in the lecture site, and before loading XML, this XML data tests the validity according to DTD or Schema specified by the standard enterprise, and XSL is applied to XML data by the DOM's XSLT processor, with which result HTML is created and transmitted to the client browser by the web server, so that there happens no blockade in the data sharing [13].



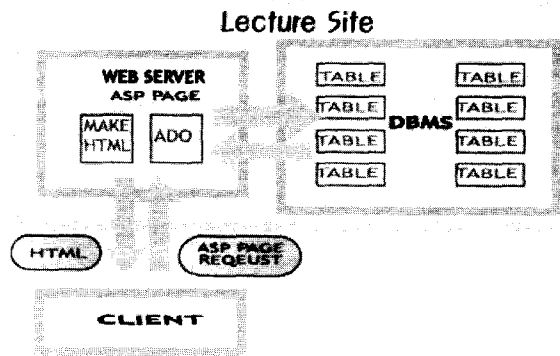

(Figure 17) Existing Cyber Lecture Management System

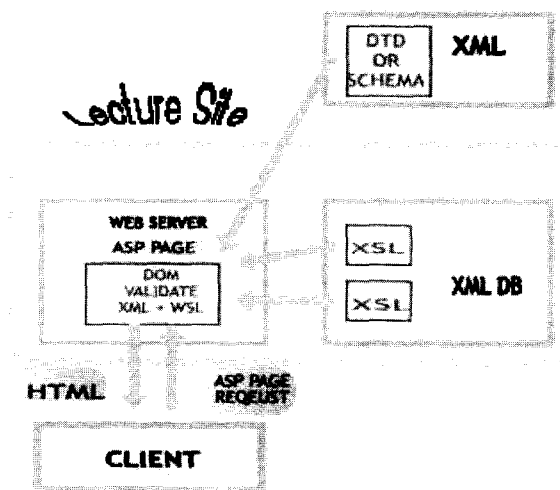

(Figure 18) Cyber Lecture Management System based on XML

## 6. Conclusion and Prospect

Therefore, on this thesis, an approach to the XML-based Meta-Modeling is discussed in order to be applied on the effective Cyber-Lecture Management System [11].

Because the information produced on the basis of the XML, a next-generation internet standard language, was to be provided through the web-based user-interface, the information applied with Meta-Modeling could be accessed without dimensional limitation. Also, with this utilized, the combined management and structural search can be possible, and reusability of the sub-documents was facilitated.

For such users as teachers, Registration Lecture, Registration Test, BBS, student information were free to be controlled. And questions are presented in web browsers. So they were easy to be made. Question amendment and search were easy and with the result of confirming survey, weak points were amended and complemented on the matters of CLMS, maximizing the system with constant update.

As for students, it was easy for them to have access to

the system with web browsers, confirmed the evaluation in the real time, and choosed the types of the examinations which they want. The results of the databasing could help the future education and pre or post inspection on the result of survey could help to determine the effectiveness of the system.

Till now, there are few effective lecture sites utilizing this, so from now on the research on the XML should be first followed, in order to ensure the growth into the site which has the capability of providing the learners with their demands and special characters and abilities.

It seems that from now on a unified structure on this field might be defined. Although the W3C is making their efforts on their ways, because of lack of coerciveness, the structural process is slow. At the present time, the XML structure is being defined at the various industries, but it is confined to one field only. The technique used here can be applicable to the educational materials and also transform the knowledge materials into another form. It is certain that the standardization concerned with cyber-education influence the quality of the education and competitiveness.

## References

- [1] Extensible Markup Language(XML), 1.0 <http://www.w3.org/TR/REC-xml>, 2003.
- [2] <http://www.edunet4u.net/top.html>, 2003.
- [3] Ch. Sub, R. Kammerl and B. Freitag, "A The chware Management Framework for Multiple Teaching Strategies," In proceedings of ED-MEDIA2000, World Conference on Educational Multimedia, Hypermedia Telecommunications, Montreal, Quebec, Canada, June, 2000.
- [4] Paul Spencer, *Professional XML Design and Implementation*, Wrox, pp.183-191, 1999.
- [5] John Griffin, *XML and SQL Server 2000*, Ne wreders, pp. 245-275, pp.301-311, 2002.
- [6] <http://www.w3.org/TR/2002/WD-DOM-Lever-3-cor-e-2-0021022>, 2003.
- [7] Raghu Ramakrishnan, J ohannes Gehrke, *Database Management Systems*, MaGRAW-Hill International edit-ions, No.2, pp.642-671, 2000.
- [8] Fakultat fur Mathematik u., Informatik Universitat passau D-94030 Passau, Germany, "A daptive knowledge Management : A MetaModeling Approach and its Binding to XML," 2000.
- [9] Hye-young kim, Hwa-sun kim, Heung-sik kim, Sang-gyun Kim, Heung-kook Choi, "Cyber lecture management system for xml based secondary education," proceedings of the International Conference on Security and Management, USA, ISBN : 1-932415-17-3, Vol.II, pp.444-448, June,

2003.

- [10] Hwa-sun kim, Hye-young kim, Heung-sik kim, Heung-kook Choi, "the Design and Implementation of Medical underwriting for XML based Insurance point information," Journal of Korean Society of Medical Informatics, Col8, Supplement1, Fall, s17-20, 2002.
- [11] Fakultat fur Mathematik u. Informatik Universitat passau D-94030 Passuau, Germany, "A daptive Knowledge Management : A MetaModeling Approach and its Binding to XML," 2000.
- [12] Slmon M.Lucas Department of Computer Science Essex, University Colchester CO4 2SQ, "Web-Based Evaluation and Development of Pattern Recognizers," ICPR, 2002.
- [13] Hye-young Kim, Young-Jin Kim, Heung-kook Choi, "a Remote Courseware Management System through the application of web based ASP.NET," Journal of korea multimedia society, Vol.6, No.4, pp.639-645, July, 2003.



### 김혜영

e-mail : hyoungk02@unitel.co.kr  
 1998년 Computer Education kyungsang University Master's Degree.  
 1999년 National convention S/W Contest received a prize Gold Medal.  
 2001년~현재 Computer Science, Inje University PhD Course.

관심분야 : Remote Education System, Computer Graphics, XML, ASP.NET.



### 김화선

e-mail : polala@chol.com  
 1991년 Nursing Masan University  
 2003년 Computer science Inje University Master's Degree

관심분야 : Multimedia, XML, Database

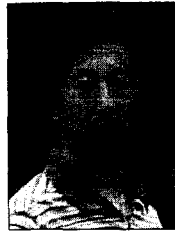

### 김흥식

e-mail : hskim@cs.inje.ac.kr  
 1985년 KAIST, Computer Science, M.S.  
 1995년 KAIST, Electrical Electronics, Ph.D.  
 1985년~1987년 ETRI, Division of Computer Development, Researcher

1987년~현재 Inje University, the School of Computer Engineering, Professor

관심분야 : Database, Internet, Application, Web database, XML



### 김상균

e-mail : skkim@cs.inje.ac.kr  
 1994년 Computer Engineering Kyung Pook University MD.  
 1996년 Computer Engineering Kyung Pook University Ph.D.

1996년~현재 Inje University, the School of Computer Engineering, Professor

관심분야 : Pattern recognition

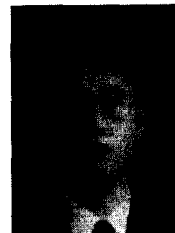

### 최흥국

e-mail : hkchoi@mitl.inje.ac.kr  
 1988년 Linkoping University, Computer Engineering Linkoping, Sweden  
 1990년 Linkoping University, Computer Engineering Linkoping, Sweden, Master's Degree

1996년 UppsalaUniversity, Computerized Image Analysis Uppsala, Sweden, Ph.D.

1997년~현재 the school of Computer Engineering Inje University Professor

관심분야 : Multimedia, Computer Graphics Computerized Image Analysis