

Molecular Emission Spectrometric Detection of Low Level Sulfur Using Hollow Cathode Glow Discharge

Il Gyo Koo and Woong Moo Lee*

Department of Molecular Science and Technology, Ajou University, Suwon 443-749, Korea

Received September 19, 2003

A highly sensitive detecting method has been developed for determining part per billion of sulfur in H₂S/Ar plasma. The method is based on the excitation of Ar/H₂S or Ar/H₂S/O₂ mixture in hollow cathode glow discharge sustained by radiofrequency (RF) or 60 Hz AC power and the spectroscopic measurement of the intensity of emission lines from electronically excited S₂^{*} or SO₂^{*} species, respectively. The RF or AC power needed for the excitation did not exceed 30 W at a gas pressure maintained at several mbar. The emission intensity from the SO₂^{*} species showed excellent linear response to the sulfur concentration ranging from 5 ppbv, which correspond to S/N = 5, to 500 ppbv. But the intensity from the S₂^{*} species showed a linear response to the H₂S only at low flow rate under 20 sccm (mL/min) of the sample gas. Separate experiments using SO₂ gas as the source of sulfur demonstrated that the presence of O₂ in the argon plasma is essential for obtaining prominent SO₂^{*} emission lines.

Key Words : Hollow cathode discharge, Emission spectroscopy, Sulfur detection, RF glow discharge, Plasma chemistry of sulfur compounds

Introduction

Gas chromatographic detectors available for the selective determination of sulfur compounds often use the optical intensity of characteristic emission lines as their sensing property. The atomic emission detector (AED) utilizes the characteristic sulfur atom lines,¹ but the flame photometric detector (FPD)^{2,3} and the sulfur chemiluminescence detector (SCD)^{4,7} focus on some molecular emission lines of sulfur-containing molecules produced by chemical reactions involving the effluent. Whereas the AED^{1,8} depend on plasma, an arc, or a spark as the atomization energy source, the FPD and SCD whose operating principle is based on molecular emissions²⁻⁷ rely on chemical reactions for the generation of the light-emitting species. The FPD, which could be the most widely used sulfur-selective detector is based on the production of sulfur atoms in H₂/O₂ flame, which combine to form electronically excited S₂^{*}.^{2,3} The SCD is based on two successive chemical reactions; first, the formation of sulfur monoxide (SO) from sulfur compounds after a series of oxidation and reduction reactions in a reducing H₂/O₂ or H₂/air flame and second, the formation of electronically excited SO₂^{*} from the reaction of the SO with ozone.^{4,7,9}

Despite its simplicity in operational principle, the FPD has some fundamental limitations such as nonlinear response to sulfur concentration and significant interferences from other species like H₂O, CO₂ and hydrocarbons.^{2,3} The SCD under proper operation is a good sulfur detector, particularly for detection of sulfur compounds at low concentrations. It produces a linear response to sulfur.^{4,7} Despite the many advantages it offers over other sulfur-selective detectors, the SCD requires for its successful operation a series of precise operational adjustments. For example, the response of the

SCD detector is highly dependent on the position of the equilibrium of the reaction

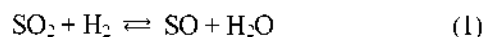

and on the degree of transfer of SO to the chamber where it meets ozone.^{5,9} The response varies sharply depending on the ratio of the actual hydrogen flow rate to the rate needed for the stoichiometric reaction (1). The response is also critically dependent on the positioning of the probe that is used to sample SO.^{9,10} The dependency is attributed to the movement of the probe tip in the reaction cell and allows variation of the flame residence time, which in turn determines the concentration of SO molecules.^{4,6,7,9} This SO sampling difficulty is somewhat alleviated by adopting a flameless combustor.⁶ However, the optimization of whole SCD operational steps to produce the light-emitting species still remains a tricky matter.

In this study, we investigate the possible use of the plasma method for generating the electronically excited molecules whose characteristic emission lines are used for the detection of sulfur compounds. Plasma sources such as inductive coupled plasma or direct current plasma, have been widely employed for atomic emission spectroscopy.⁸ Atomic emission spectroscopy based on plasma sources inevitably depended on high power consumption and could not avoid being bulky in the instrumentation. However, with the advent of various forms of plasma excitation sources there have been drastic improvements in power consumption and compactness of the devices. Recently, the advancement of the hollow cathode discharge (HCD) method renders significant reduction in electrical energy to sample atomization and excitation, a key step for the atomic emission spectroscopy.¹¹⁻¹⁸ HCD is an extremely efficient method for generating glow discharge (GD) per a given dissipated

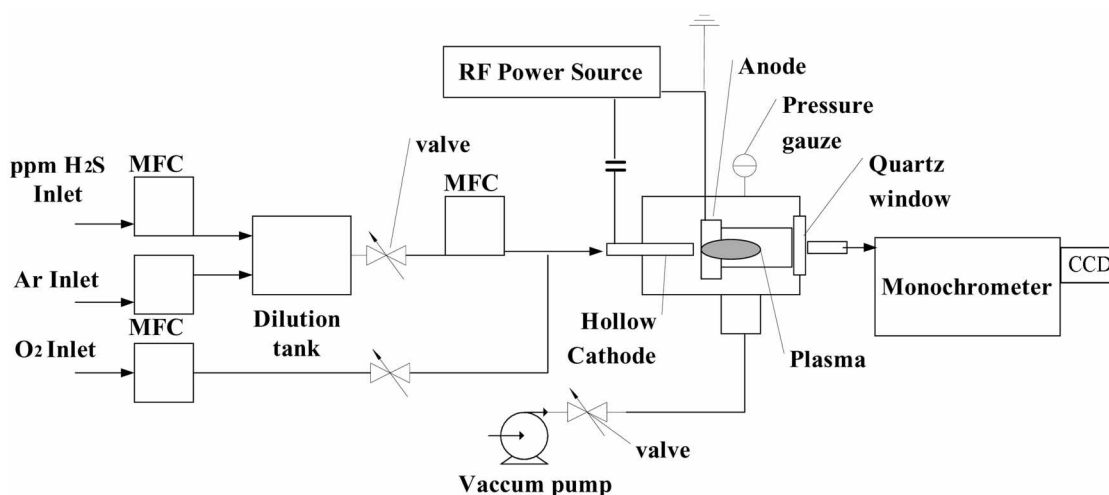

Figure 1. Schematic diagram of the experimental setup.

electrical energy compared with other plasma source methods.¹⁹ Recently, various types of low power, plasma source-based, molecular emission detectors were reported. Eijkel *et al.*²⁰ prepared a direct current micro plasma detector on a glass chip that could analyze methane down to the concentration of 600 ppm. But due to the sputtering of the cathode material at reduced pressure, the lifetime of the detector was limited to ~2 h. A low power microwave plasma detector was recently developed by Engel *et al.*²¹ A plasma with a longitudinal extension of 2-3 cm was generated with a forward power 10-40W. A low power, atmospheric pressure, pulsed plasma was developed by Los Alamos National Laboratory.²² The average operational power of the detector was less than 0.2 W. This low-power pulsed plasma detector was evaluated for organic vapor detection. We applied the analytical potential of low power radiofrequency (RF) or AC glow discharge (RF-GD or AC-GD) based on high efficient HCD to the generation of electronically excited sulfur-containing molecules with the aim of constructing a much more simplified detector than FPD or SCD for low level sulfur analysis.

With such an aim in mind, geometrical adjustments of the hollow cathode and anode configuration were explored to generate RF-GD or AC-GD out of Ar/H₂S or Ar/H₂S/O₂ mixture and to direct the plasma toward the optical detector. Then, the emission spectra of the mixture were examined as to whether they contained the characteristic emission lines or bands of S₂^{*} or SO₂^{*} that can be used as the reference peaks for the conventional FPD or SCD.^{2,4,5,23} Finally, the molecular emission intensity of the characteristic line or band of the spectra was measured as a function of the H₂S concentration and of the flow rate of the mixture to evaluate the potential of the plasma method as an analytical tool for sulfur analysis.

Experimental Section

The schematic diagram of the experimental setup is shown in Figure 1. The experimental system basically consists of

three parts: the sample gas preparation section, the discharge part and the optical detector. A diluted H₂S sample gas having a concentration 5 or 100 ppmv in argon (Ar) was prepared and certified by Rigas Co. (Daejeon, Korea) with the error range being smaller than ± 2%. This sample gas, before entering the discharge section, was further diluted with Ar gas (99.999%) using Mass Flow Controllers (MFCs) (Model 3440, Kofloc, Japan, ± 1% precision) so that its final concentration fell in the range of 5 to 500 ppbv. This gas with or without being mixed with oxygen gas was led to enter the discharge chamber through one open end of the tubular hollow cathode made of stainless steel (3 cm long, 3 mm i.d.). The flow rate of the oxygen gas (99.999%), if it was to be included in the sample gas, was set to equal that of the H₂S gas after the final dilution.

The details of the configuration of the electrodes are shown in Figure 2. The tubular hollow cathode actually played the role of a gas nozzle as well as exciting the gas molecules. The anode was grounded and electrically separated from the cathode by a Viton o-ring. The anode made of 1.5 cm thick stainless steel plate was 3 mm from the end of the tubular cathode. It had a center orifice of 3 mm

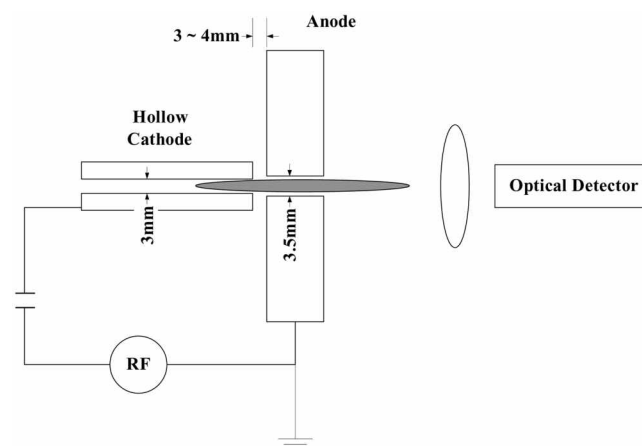

Figure 2. Geometric dimensions of the electrodes.

diameter that directed the glow discharge to extend toward the optical detector. The pressure inside the plasma chamber monitored by a convection gauge (KVC-330, KVC instruments, Korea) was maintained at less than 1.5 mbar, using a rotary pump with a liquid nitrogen trap. A 13.56 MHz rf generator (YSE-03F, Young Sin Engineering, Korea) with the maximum power of 30 W or 60 Hz AC was used as the power source for inducing the discharge.

The emitted light from the discharge was collected by an optical fiber cable through the UV-grade quartz window and transmitted to the monochromator. In this study two types of the monochromator and CCD camera combination were used. For the broader band (200-850 nm) study the combination of the 250 mm monochromator (Model Spectro-250, ARC, USA) and the CCD camera (Model ST-6, SBIG, USA) was used, whereas for the narrower band (250-450 nm) study the 750 mm Czerny-Turner type monochromator (Model DM 702, Dongwoo Optron, Korea) attached to the CCD camera (Model DB401-UV, Andor, USA) was used. The spectroscopic data collection for the 200-450 nm range was accomplished using a grating 150 gr/mm, 2400 gr/mm with the resolution of 0.5 nm, 0.01 nm, respectively.

Results and Discussions

Discharge stability. The configuration of the discharge chamber, particularly the arrangements of the electrodes and the flow path of the sample gas, should be carefully examined from the standpoint of fulfilling the following requirements—stability of the RF- or AC-GD and high emission intensity of the analyte. The configuration shown in Figure 2 proved to meet the criteria by ensuring sustainable glow discharge and efficient photon collection by the detector. The chamber pressure that was maintained at $1.5\text{--}2.5 \pm 0.1$ mbar was also an important factor in meeting such stability. Introducing the sample gas into one open end of the tubular hollow cathode contributed significantly to ionizing the molecules at the expense of low RF or AC power. The stable glow discharge was formed with the power consumption lower than 20 W in most cases. With the dissipation of such electrical energy the temperature of the surface of the electrode compartment did not rise above 40 °C. The plasma gas was protruded a couple of cm out of the anode orifice toward the quartz lens. Reversal of the position of the two electrodes in RF discharge failed to extend the plasma toward the lens, whereas the reversal in AC discharge did not affect the nature of the discharge. The center orifice of the anode definitely played an important role in directing the glowing plasma gas toward the light collector. The injection of the oxygen gas to the H₂S/Ar sample gas did not affect the stability of the discharge.

Emission spectra. The broad band (200-850 nm) spectra taken for either H₂S/Ar or H₂S/O₂/Ar plasma gas (the concentration of H₂S was 100 ppbv) did not show the prominent emission of sulfur atom at the peak wavelength of 545.38 nm. Thus the emission study was concentrated on the search of the molecular lines of sulfur compounds that

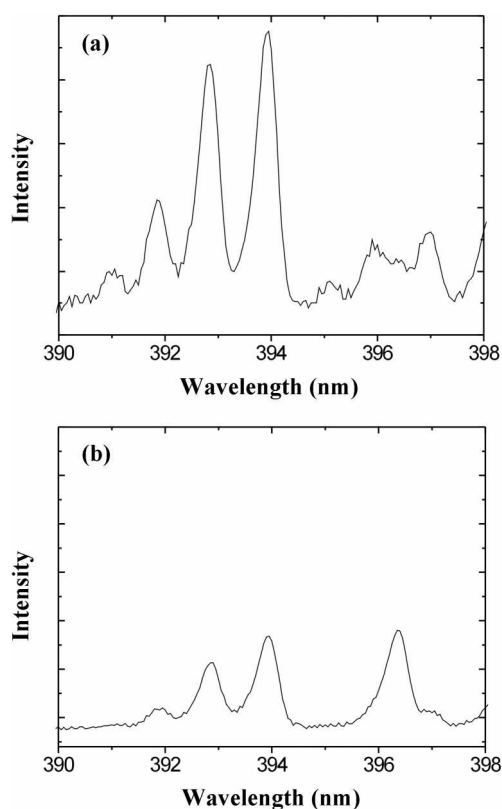

Figure 3. Emission spectra of H₂S/Ar plasma powered by (a) RF or (b) AC.

usually fall in the range of 250-450 nm bands.

The emission spectra of a S₂⁺ band in the range of 390 to 398 nm are shown in Figure 3 for the H₂S/Ar plasma powered by AC or RF. Some other peaks around 396 nm are interpreted to be the characteristic Argon lines. The spectra of a SO₂⁺ band in the range of 348 to 352 nm are shown in Figure 4 for the H₂S/O₂/Ar plasma, also powered by RF or AC. For either band the spectra obtained from the application of RF power source show more intense peaks than AC with their power level maintained at the same value. However, the spectrum from AC powered plasma was clear enough for quantitative sulfur analysis. Replacement of RF by 60 Hz AC power increases a great deal the practical value of the plasma method for sulfur analysis.

H₂S/Ar gas: From the typical emission spectrum shown in Figure 3, the emission peak at the wavelength at 393.89 nm was selected as the reference line because the intensity of that peak exhibited the relationship most close to a linear one with respect to the change in H₂S concentration. The plots of the intensity vs. the concentration are shown in Figure 5 at different flow rates of the sample gas. The plots show that the relationship between the intensity and the concentration deviates from the linear with an increase in the flow rate. Up to the flow rate of 20 sccm the slope of the relationship is nearly a straight line. However, as the rate exceeds 60 sccm the slope shows a significant deviation from a straight line. Here we digress briefly to examine the origin of such non-linear response in other detection systems.

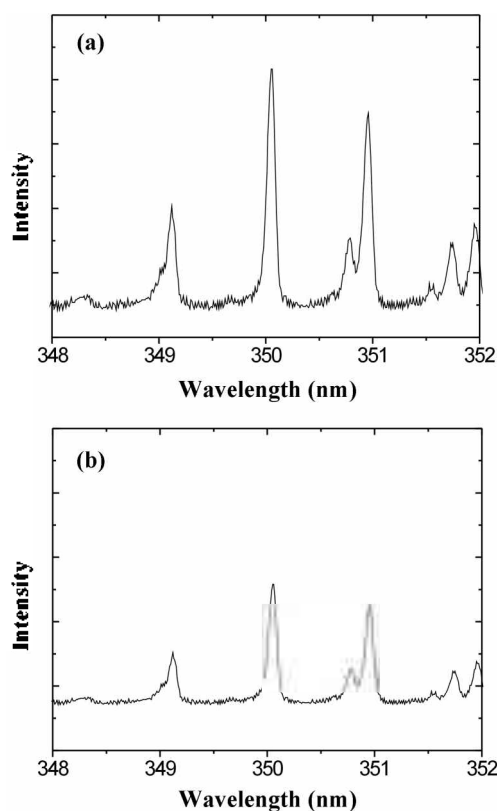
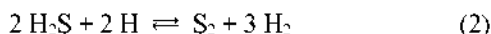
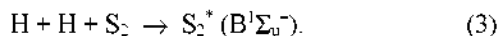

Figure 4. Emission spectra of $\text{H}_2\text{S}/\text{O}_2/\text{Ar}$ plasma powered by (a) RF or (b) AC.

In FPD, the non-linear response of the emission intensity to H_2S concentration is explained by the following model.² First, all sulfur-containing compounds yield H_2S as a primary combustion product from reactions in the H_2/O_2 flame. Then H_2S undergoes the reaction



that rapidly reaches equilibrium (with equilibrium constant K). Then the S_2 molecule can be excited with energy produced from the combination of two hydrogen atoms



Then, the intensity I depends on the concentration of H_2S by the equation

$$I = k [\text{S}_2^*] \propto K [\text{H}_2\text{S}]^2 \quad (4)$$

In general, I depends on the concentration of a sulfur compound $[\text{S}]$ by

$$I \propto [\text{S}]^n \quad (5)$$

where n should be 2 according to the model described above. But it was found experimentally that the n value ranges from 1 to 2.

When H_2S is excited directly in electrical discharge only in the presence of Ar molecules, the decomposition and excitation path may follow the following steps

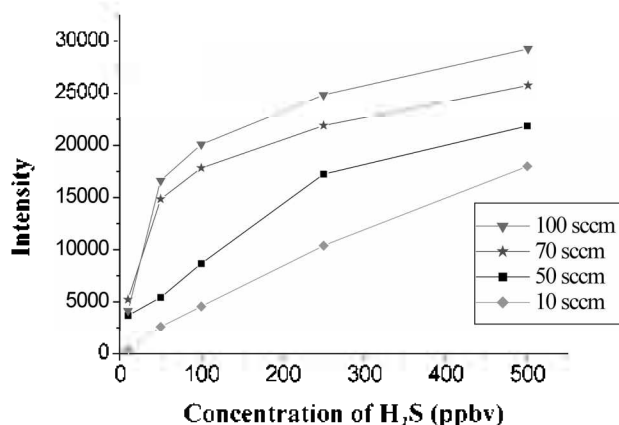
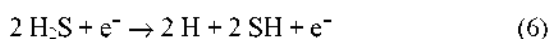
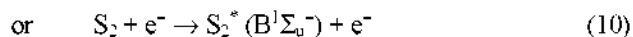
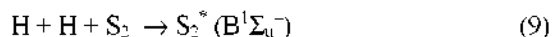
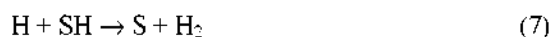
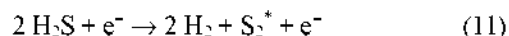

Figure 5. The plots of the S_2^* emission line intensity vs. the sulfur concentration at various flow rates of the sample gas (sccm, a unit of flow rate, equals to mL min^{-1} .)



And the overall reaction becomes



Apparently the deviation of the plot from linearity implies that the reaction (11) does not attain rapid equilibrium. Or the fact that the linearity was roughly achieved with a flow rate under 10 sccm could imply that with the gradual increase in the rate, the treating capacity of the plasma method to convert the sample gas into S_2^* could have reached the upper limit.

$\text{H}_2\text{S}/\text{O}_2/\text{Ar}$ gas: The positions of major peaks of the emission spectrum shown in Figure 4, particularly in the range between 348 and 352 nm, coincide exactly with the lines observed in SCD.^{5,23} Among the many lines having significant intensity, the emission peak at the wavelength of 350 nm was selected as the reference line.^{4,5,23} The spectrum also showed a weak signal due to the characteristic line of S_2^* at 394 nm that was superimposed on other continuums. This indicates that the sulfur in the compound more likely reacts with oxygen under the discharge rather than staying as its elementary form. The product gas was also analyzed using FTIR and the existence of SO_2 was clearly confirmed by the main peak at 1360.9 cm^{-1} . As in the case of $\text{H}_2\text{S}/\text{Ar}$, the spectrum from AC powered $\text{H}_2\text{S}/\text{O}_2/\text{Ar}$ plasma was clear enough for quantitative sulfur analysis.

The plots of the intensity vs. the concentration are shown in Figure 6 at different flow rates of the sample gas. The intensity shows clear linear response to the concentration in contrast with the non-linear response exhibited in $\text{H}_2\text{S}/\text{Ar}$ sample gas. In setting the total flow rate the ratio of the rate of oxygen gas to that of the $\text{H}_2\text{S}/\text{Ar}$ gas was adjusted to be fixed, which corresponded with 10 sccm of oxygen to 50 sccm of the $\text{H}_2\text{S}/\text{Ar}$ gas. But it was found that the intensity

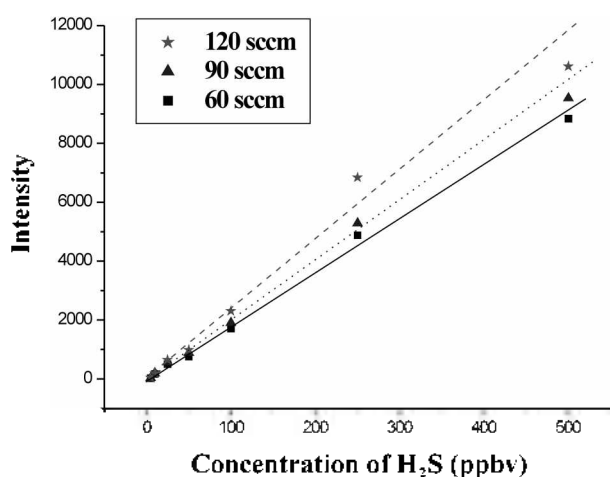

Figure 6. The plots of the SO_2^* emission line intensity vs. the sulfur concentration at various flow rates of the sample gas.

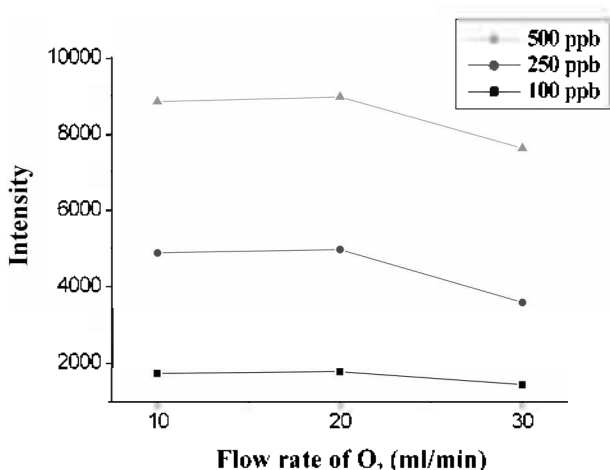

Figure 7. Effect of the flow rate of O_2 on SO_2^* emission line.

was also a function of the ratio as shown in Figure 7. As the flow rate of oxygen was increased from 10 to 30 sccm the intensity started to decrease around the rate of 20 sccm. This is related to the diminution of the plasma intensity as the oxygen concentration was increased since it should be much more difficult to get sustained plasma with oxygen than with Ar gas. In the present study the lowest concentration of H_2S we analyzed was 5 ppbv, not because of the limit in the spectroscopic resolution but because of the difficulty with sample mixing in achieving the concentration below 5 ppbv. While employing more accurate mixing method the plasma detector may as well be tested for its capability to determine sulfur compounds in concentration range under 5 ppbv.

The detailed mechanism of the SO_2^* generation in $\text{H}_2\text{S}/\text{O}_2/\text{Ar}$ plasma should be complex. For example, in an oxygen discharge, there can be significant ground-state concentrations of O , O_2 , O_3 , O^+ , O_2^+ , O_2^- , O^- , and electrons, as well as metastable states such as the ^1D and ^1S states of O and the $^1\Delta_g$ and $^1\Sigma_g$ states of O_2 .^{24,26,27} Thus oxygen-involved reactions can have a wide variety of reaction paths.^{23,25} The possible reaction paths involve, in addition to the reactions (6) and (7),

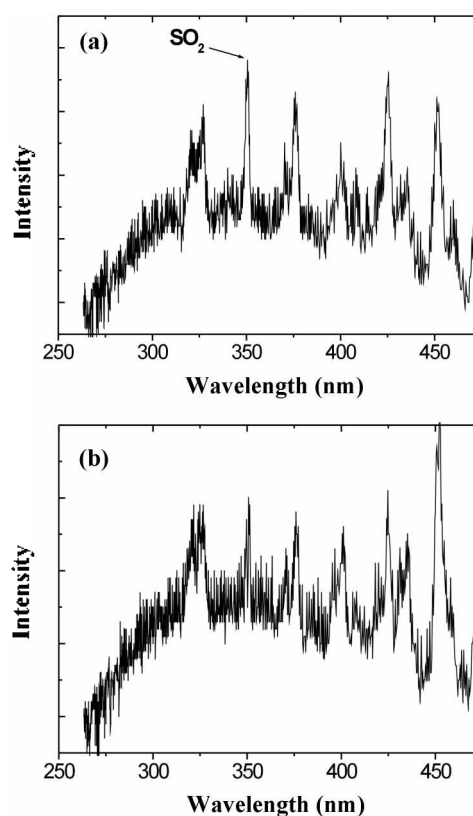
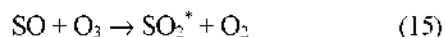
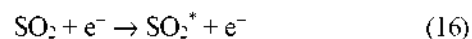

Figure 8. Emission spectra of (a) $\text{SO}_2/\text{O}_2/\text{Ar}$ plasma and (b) SO_2/Ar plasma.



The excited state of SO_2 can also be generated by



Generally the cross section of an electronic state excitation by electron collisions as shown in reaction (16) is lower than that of the excitation through a chemical reaction as shown in reaction (15).

To figure out the reaction path for generating the SO_2^* we used instead of $\text{H}_2\text{S}/\text{O}_2/\text{Ar}$ a gas mixture containing SO_2 . The emission spectrum of SO_2/Ar or $\text{SO}_2/\text{O}_2/\text{Ar}$ gas, which was subject to the hollow cathode discharge, is shown in Fig. 8. While the $\text{SO}_2/\text{O}_2/\text{Ar}$ plasma displayed very intense characteristic SO_2^* lines, the SO_2/Ar plasma did not. Apparently reaction paths other than the reaction (16) could constitute the major pathway for generating the SO_2^* species. One possible mechanism could be

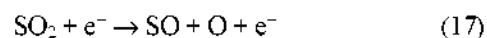

Together with O_3 that was generated by the reactions (12) and (13), the SO produces SO_2^* through the reaction (15). Also from the study on SO_2 gas it became clear that this plasma method can be extended for detecting sulfur placed in any other sulfur compounds.

Conclusions

A very simple and sensitive method for detecting low level sulfur has been developed utilizing hollow cathode discharge to generate electronically excited and light emitting sulfur species. An electric discharge, with the help of RF or 60 Hz AC power, was generated through Ar/H₂S or Ar/H₂S/O₂ gas mixture in which H₂S was used as the source compound of sulfur. The glowing plasma formed by a stable discharge through the sample gas led to the generation of electronically excited S₂^{*} or SO₂^{*} species, respectively that emit light with characteristic lines. The total power consumption for generating a stable glow plasma at 2 mbar pressure did not exceed 30 W. The SO₂^{*} species showed an excellent linear response to the sulfur concentration ranging from 5 to 500 ppbv. But the S₂^{*} species exhibited a linear response to the sulfur concentration only when the flow rate of the sample gas mixture was maintained under 20 sccm. The configuration of the electrodes for the discharge was optimized such that a tubular cathode with a 3 mm inner diameter, playing the role of a gas nozzle, helped ionize the gas molecules and a thin disk anode with a centered small hole directed the plasma flare toward the light detector. Separate experiments using SO₂ gas as the source of sulfur demonstrated that the presence of O₂ in the argon plasma was essential for obtaining prominent SO₂^{*} emission lines.

Acknowledgements. This work was financially supported by the Mid- and Long-term Nuclear R&D Fund provided by the Republic of Korea Ministry of Science and Technology.

References

- Centineo, G.; Fernandez, M. *Anal. Chem.* **1997**, *69*, 3702.
- Farwell, S. O.; Barinaga, C. J. *J. Chromatogr. Sci.* **1986**, *24*, 483.
- Steven, R. K.; Mulik, J. D.; Okeeffe, A. E.; Krost, K. J. *Anal. Chem.* **1971**, *43*, 827.
- Benner, R. L.; Stedman, D. H. *Applied Spectroscopy* **1994**, *48*, 848.
- Benner, R. L.; Stedman, D. H. *Anal. Chem.* **1989**, *61*, 1268.
- Shearer, R. L. *Anal. Chem.* **1992**, *64*, 2192.
- Benner, R. L.; Stedman, D. H. *Environ. Sci. Technol.* **1990**, *24*, 1592.
- Bings, N. H.; Bogaerts, A.; Broekaert, J. A. C. *Anal. Chem.* **2002**, *74*, 2691.
- Benner, R. L.; Stedman, D. H. *U.S. Patent 5,424,217*, 1995.
- Zachariah, M. R.; Smith, O. I. *Combustion and Flame* **1987**, *69*, 125.
- Orellana-Velado, N. G.; Fernandez, M. *Spectrochim. Acta part B* **2001**, *56*, 113.
- Anfone, A. B.; Marcus, R. K. *J. Anal. At. Spectrom.* **2001**, *16*, 506.
- Marcus, R. K. *Glow Discharge Spectroscopies*. Plenum Press: New York, 1993.
- Marcus, R. K.; Davis, W. C. *Anal. Chem.* **2001**, *73*, 2903.
- Parker, M.; Hartenstein, M. L.; Marcus, R. K. *Spectrochim. Acta Part B* **1997**, *52*, 567.
- You, J.; Fanning, J. C.; Marcus, R. K. *Anal. Chem.* **1994**, *66*, 3916.
- You, J.; Dempster, M. A.; Marcus, R. K. *Anal. Chem.* **1997**, *69*, 3419.
- Dempster, M. A.; Marcus, R. K. *Spectrochim. Acta part B* **2000**, *55*, 599.
- Chuaqui, H.; Favre, M.; Soto, L.; Wyndham, E. S. *IEEE Trans. Plasma Sci.* **1993**, *21*, 778.
- Eijkkel, J. C. T.; Stoeri, H.; Andreas, M. *Anal. Chem.* **2000**, *72*, 2547.
- Engel, U.; Bilgic, A. M.; Haase, O.; Voges, E.; Broekaert, A. C. *Anal. Chem.* **2000**, *72*, 193.
- Jin, Z.; Su, Y.; Duan, Y. *Anal. Chem.* **2001**, *73*, 360.
- Halstead, C. J.; Thrush, B. A. *Proc. Roy. Soc. A* **1966**, *295*, 380.
- Jeong, J. Y.; Park, J.; Henins, I.; Babayan, S. E.; Tu, V. J.; Selwyn, G. S.; Ding, G.; Hicks, R. F. *J. Phys. Chem. A* **2000**, *104*, 8027.
- Chu, Y.; Wang, H.; Li, J.; Cheng, P.; Cao, D. *Chem. Phys. Lett.* **2002**, *366*, 147.
- Brown, S. C. *Basic Data of Plasma Physics*; AIP press: New York, N.Y., 1994.
- Lieberman, M. A.; Lichtenberg, A. J. *Principles of Plasma Discharge and Materials Processing*. John Wiley & son, Inc: New York, N.Y., 1994.