

JPE 4-2-2

Power Module Bridge Type Auxiliary Resonant AC Link Snubber-Assisted Three-Phase Soft Switching Inverter

Hisashi Iyomori, Shin-ichiro Nagai, Masanobu Yoshida, Eiji Hiraki and Mutsuo Nakaoka[†]

Department of Electrical and Electronics Engineering, Yamaguchi University, Yamaguchi, Japan

ABSTRACT

This paper presents a novel three-phase power module bridge type auxiliary resonant AC link snubber for the three-phase voltage-fed sinewave soft switching PWM inverter operating under specific instantaneous space voltage vector modulation. The operating principle of this resonant snubber is described for current source load model during one switching period, along with its design approach based on the simulation data. The performance evaluations of space vector modulation three-phase sinewave soft switching inverter with a new three-phase active auxiliary resonant AC link snubber are discussed as compared with those of three-phase voltage source-fed sinewave hard switching PWM inverter with a standard space voltage vector modulation strategy. The power loss analysis and conventional efficiency estimation of three-phase soft switching PWM inverter using IGBT modules are carried out including all the conduction power losses based upon the measured v-i characteristics of IGBT and its antiparallel diode as well as their switching losses.

Keywords : Power module bridge type auxiliary resonant AC link snubber, Soft switching, Three-phase sinewave inverter, Specific instantaneous space voltage vector modulation, Power loss analysis

1. Introduction

In recent years, research and development of the high frequency soft switching sinewave PWM inverter circuit and system application technologies have attracted special interest to implement high operating performances related to waveform high quality, quicker responses, higher efficiency of a three-phase voltage source type sinewave PWM inverter using IGBT power module packages. On the other hand, the three-phase active rectifier with sinewave input line current shaping and unity power factor, and a three-phase bidirectional converter and active pow

-er filter are in addition to instantaneous static var compensator (Active SVC) which effectively incorporate the soft switching commutation snubber circuit have been discussed and evaluated from an application point of view.

In general, the sinewave soft switching PWM power conversion circuit and system topologies using active quasi-resonant snubbers are schematically divided into four technological categories; resonant DC link, resonant AC link and resonant bridge leg link, and resonant arm link. In particular, the power conditioning and processing converter circuits and systems using IGBT-IPM (Intelligent Power Module) is substantially more suitable and acceptable for either the auxiliary resonant DC link^{[1],[2]} or auxiliary resonant AC link^{[3]-[5]} snubber scheme. Of these, the auxiliary resonant AC link snubber circuit can be more effectively available for medium

Manuscript received May 30, 2003; revised Mar. 2, 2004.

[†] Corresponding Author: nakaoka@pe-mews.eee.yamaguchi-u.ac.jp

Tel: +81-836-85-9472, Fax: +81-836-85-9472

capacity and large capacity power and energy processing applications as compared with those of the auxiliary resonant DC link snubber circuits. The authors have done performance evaluations so far on the star type quasi-resonant AC link snubber scheme as well as the delta type quasi-resonant AC link snubber scheme based on a bidirectional switch configured resonant AC link scheme^{[6],[7]} proposed in addition to the single resonant inductor type resonant AC link snubber scheme^[8].

This paper proposes the power module bridge package type resonant AC link snubber for three-phase voltage type soft switching sinewave PWM inverter^[1] implementation based on a bidirectional switch type resonant AC link scheme. The operation principle of this soft switching inverter circuit operating under the specific instantaneous space vector sinewave modulation strategy is described, including remarkable features. The practical design approach of the resonant AC link snubber circuit proposed here is graphically described for the simulation characteristic data. The comparative evaluations of the power loss analysis simulation developed by the authors is actually carried out for three types of the three-phase voltage source type soft switching and hard switching PWM inverters using the IGBT power modules. The practical effectiveness of this three-phase soft switching inverter breadboard setup is verified on the basis of the computer-aided simulation data and output waveform characteristics.

2. Resonant AC Link Snubber Circuit

2.1 Circuit Description

The main circuit configuration of the single-phase voltage-fed soft switching sinewave PWM inverter using auxiliary bidirectional switch type resonant AC link snubber circuit is schematically shown in Fig. 1. This soft switching inverter operating under a principle of zero voltage switching (ZVS) has lossless snubber capacitors C_{r1} - C_{r4} in parallel with the main active power switches Q_1 - Q_4 in a bridge arm. In the three-phase inverter output ports, the edge resonant pulse soft commutation circuit consists of the additional quasi-resonant inductor L_r in series with auxiliary bidirectional power switches Q_{a1} and Q_{a2} , including the lossless snubbing capacitors C_{r1} - C_{r4} in

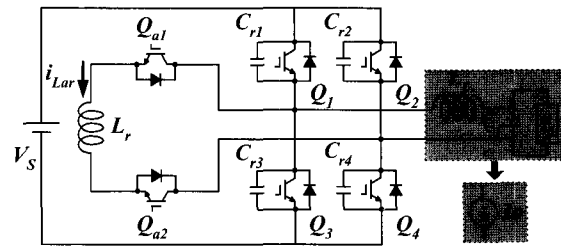

Fig. 1. An auxiliary resonant AC link snubber with bidirectional switch circuit.

the voltage source type inverter treated here. The main power switches in the inverter bridge arm can achieve zero voltage soft switching due to the active auxiliary edge resonant pulse commutation. The lossless capacitive snubbers in parallel with the main power switches to be turned off have to be charged from zero to the DC supply voltage V_S during the dead time period. As a result, each main power switch can operate with ZVS commutation at turn off mode transition. On the other hand, the lossless capacitive snubber in parallel with the main power switch to be turned on has to be discharged toward zero from the supply DC voltage V_S . The current through the main power switch commutates naturally to the antiparallel diode of IGBT. In this case, the main power switch can completely achieve ZVS and ZCS hybrid commutation at turn off mode transition. And then, the auxiliary active power switches Q_{a1} and Q_{a2} can achieve ZCS commutation at turn on and turn off mode transitions with the aid of the resonant inductor L_r and the resonant capacitor $C_r=(C_{r1} \sim C_{r4})$ during the dead time period.

2.2 Circuit Operation

All the power switches $Q_1 \sim Q_4$ and Q_{a1} , Q_{a2} of the auxiliary resonance AC link snubber circuit (see Fig. 1) can operate under an ideal design condition in principle, the operating mode of this prototype inverter is in principle divided into eight circuit commutation modes for the positive direction ($I_O > 0$) of the generalized arbitrary load current source I_O in addition to $I_O < 0$ during one sampling period. Each equivalent circuit for the operating mode of this resonant snubber circuit is depicted in Fig. 2. The gate voltage pulse timing sequences and typical voltage and current operating waveforms of this active auxiliary resonant AC link snubber circuit in Fig. 2 are

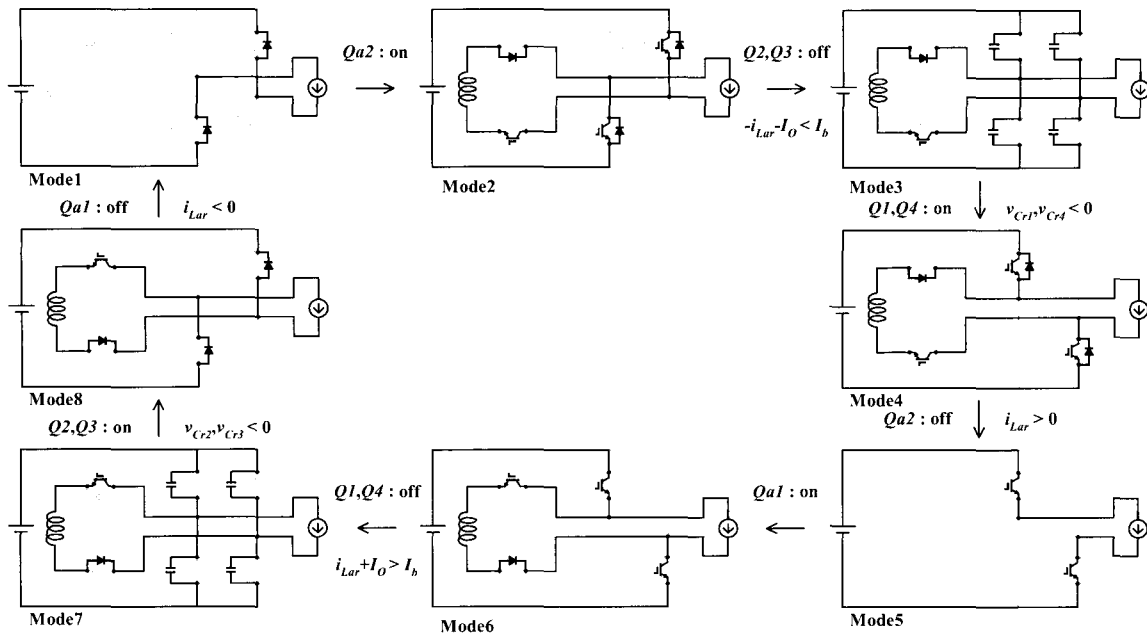

Fig. 2. Mode transitions and equivalent circuit.

respectively illustrated in Fig. 3. The operation modes 1 to 4 and the operation modes 5 to 8 are respectively the same periodic operation. The operation modes 1-4 will be explained below;

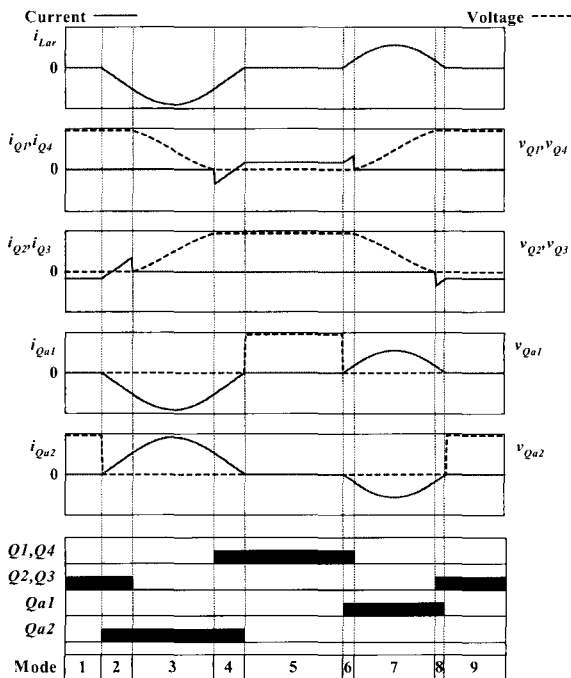

Fig. 3. Voltage and current operating waveforms.

Mode 1 In the first place, Q_2 and Q_3 are now conducting. It is assumed that the switch current is flowing through the antiparallel diode of D_2 and D_3 . Q_{a2} turns on with ZCS in the active auxiliary resonant AC link snubber, when the switching mode transitions are provided in accordance with the gate voltage pulse signal sequences.

Mode 2 The current i_{Lar} through L_r is increased lineally, when Q_{a2} turns on. The currents passing through S_2 and S_3 when the current i_{Lar} exceeds the equivalent load current I_0 with the arbitrary value. Q_2 and Q_3 in this inverter side are respectively turned off with ZVS, when the resonant inductor current i_{Lar} compensates an equivalent loss component in the quasi-resonant snubber circuit for a certain minimum value in order to maintain ZVS commutation and the lossless snubber capacitor has to accumulate enough current to discharge and charge.

Mode 3 The lossless snubber capacitors C_{r2} and C_{r3} are respectively charged from the zero voltage to the DC supply voltage V_s , when Q_2 and Q_3 are respectively turned off with ZVS. On the other hand, the lossless snubber capacitors C_{r1} and C_{r4} are respectively discharged from the DC supply voltage V_s to the zero voltage. In addition to these, the resonant inductor current i_{Lar} commutates naturally to the antiparallel diodes D_1 and D_4 , when

discharging and charging operation of the lossless snubber capacitors C_{r1} - C_{r4} in the full bridge circuit are completed without their residual charges. And, Q_1 and Q_4 can be ideally turned on with both ZVS and ZCS.

Mode 4 The currents passing through Q_1 and Q_4 continues flowing through the antiparallel diodes D_1 and D_4 . The resonant inductor current i_{Lar} is being decreased lineally. The current passing through S_1 and S_4 , when the resonant inductor current i_{Lar} , begin to be generally smaller than an arbitrary equivalent load current I_O . Q_{a2} can be turned off with ZCS, when the resonant inductor current i_{Lar} decreases toward zero.

2.3 Circuit Design Resonant AC Link Snubber

Circuit parameter design specifications of an active resonant AC link snubber treated here are indicated as follows; switching frequency $f_s=20$ [kHz], DC power source supply voltage $V_S=200$ [V], output voltage $V_O=100$ [V-rms], output power rating $P_O=2$ [kW] as the laboratory power level for the three-phase balanced resistive load. The design conditions of this circuit to specify for this resonant AC link snubber; the resonant AC link snubber circuit parameters are to be respectively determined in the followings.

- The transition operation period of quasi-resonant commutation mode is to be designed so as to be 1/10 (5.0[μ s]) of the switching period.
- Peak voltage and current stresses across the power semiconductor device; IGBTs used here is to be lowered.

The relationship between the operating time Δt_b for Mode 2 and inductance of the resonant inductor is illustrated in Fig. 4. In the time interval of which the load current in Fig. 3 is the maximum value ($I_O=30$ [A]), the time Δt_b in Mode2 is estimated at about 1/3 in the whole commutation operation time on the basis of a design circuit criteria. The inductance L_r of the resonant inductor is to be designed for $L_r=8.0$ [μ H] observing from Fig. 4. Next, L_r is fixed so as to be 8.0[μ H]. Then, the lossless snubber capacitor value is to be changed, the interval time Δt_r during the quasi-resonant commutation operation is represented in Fig. 5. Observing these figures, the capacitance of the lossless snubber capacitor C_r is specified so as to meet the both conditions of (a) and (b) mentioned above.

Therefore, the lossless snubbing capacitor capacitance is designed for $C_r=70.0$ [μ F].

The circuit design specifications and circuit parameters for the auxiliary resonant AC link snubber-assisted single-phase voltage source type full bridge inverter in Fig.1 are indicated in Table I. The operating waveforms of this resonant AC link snubber circuit are shown in Fig. 4. The operation for $I_O<0$ is almost similar to that mentioned above for $I_O>0$.

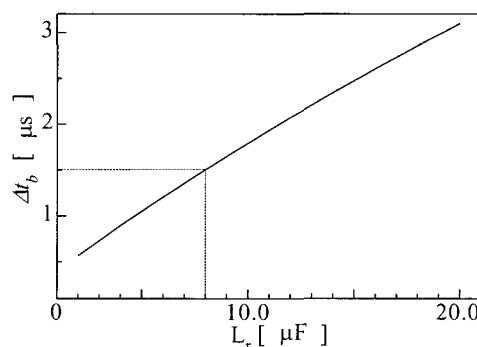

Fig. 4. Δt_b - L_r characteristics.

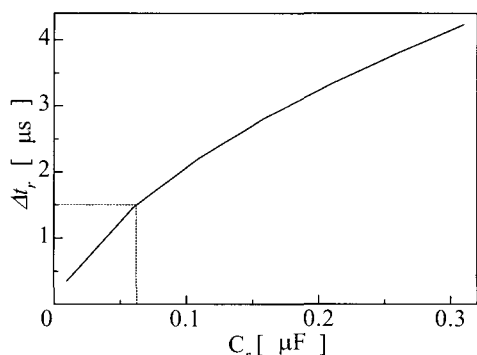

Fig. 5. Δt_r - C_r characteristics.

Table 1. Design specifications of resonant AC link snubber and circuit parameters.

Inverter specifications	Symbol	Value
DC Source voltage	V_O	200[V]
Switching frequency	f_s	20[kHz]
Resonant inductor	L_r	8.0[μ H]
Lossless snubber capacitor	C_r	70.0[nF]
Output Voltage in RMS	V_O	100[V]

2.4 Circuit Parameter of Inverter Low Pass Filter

The LC parameters of the low pass filter of the inverter are designed on the basis of % impedance; 7%. The condition is provided to be the output voltage $V_O=100$ [V-rms], the maximum output current $I_{O_max}=30$ [A], the output voltage frequency $f_o=60$ [Hz], cut off frequency $f_c=2.0$ [kHz] of the low pass filter (LPF). The inductance of the filter inductor is $L_f=928.0$ [μ H] and the value of the filter capacitor is set to $C_f=6.82$ [μ F]. The circuit parameters of this voltage source type inverter are indicated in Table 2.

3. Three-Phase Soft Switching Inverter

A bidirectional switch type auxiliary resonant AC link snubber-assisted soft switching inverter using IGBTs is

Table. 2. Design inverter specifications and circuit parameters.

Item	Symbol	Value
Output voltage in RMS	V_O	100[V]
Output voltage frequency	f_o	60[Hz]
Inductance of filter inductor	L_f	928.0[μ H]
Capacitance of filter capacitor	C_f	6.82[μ F]
Resistive load	R_l	5.0[Ω]
Inductive load	R_l	4.0[Ω]
	L_l	7.96[mH]

extensively introduced as a three-phase voltage type inverter. The star type resonant AC link snubber and delta type resonant AC link snubber and single resonant inductor type resonant AC link snubber are considered for the resonant AC link snubber. In addition, this time proposed newly three-phase power module bridge type auxiliary resonant AC link snubber. The circuit topology of a three-phase power module bridge package type resonant AC link snubber-assisted three-phase voltage type soft switching inverter using IGBTs is represented in Fig. 6.

The main features of this three-phase voltage-fed inverter topology have simple, compact, reliable and interchangeable circuit configuration, which is composed of using three-phase auxiliary power module bridge snubber as well as the three-phase power module bridge package inverter. In addition, the numbers of power semiconductor switching devices conducting in series can be considerably reduced for the edge resonant snubber switching operation. Moreover, the power semiconductor modules of 2 in 1 and 6 in 1 power module type or IPM can be conveniently applied for this kind of three-phase voltage source type sinewave PWM inverter operating under specific space voltage vector modulation.

4. Specific Instantaneous Space Voltage Vector for Resonant AC Link Snubber Three-Phase Inverter

The instantaneous space voltage vector synthesizes the voltage or current instant value of each-phase (u, v, w) in arbitrary time to three-phase AC. In order to realize out

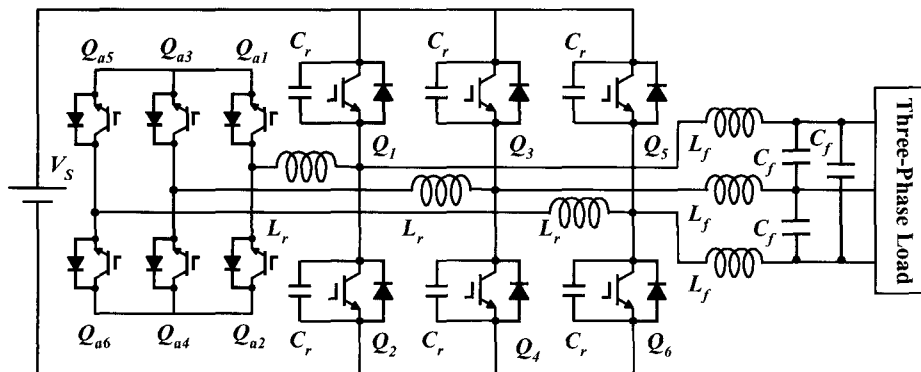

Fig. 6. Power module bridge package type auxiliary AC resonant assisted three-phase voltage source inverter.

soft switching of the three-phase voltage type inverter used resonant AC link snubber circuit, it is necessary to operate a quasi-resonant snubber circuit on each switching point. But it is impossible to apply the voltage for passing current through resonant inductor to an active auxiliary resonant snubber circuit in the state of a zero voltage vector, because each phase voltage of three-phase voltage type inverter is equal. Moreover, when performing single-phase switching, the closed loop for the current through active auxiliary resonant snubber circuit based on the resonant inductor can be made. However, after completing switching operation, the voltage between the resonant inductor does not exist closed loop through the DC power supply voltage V_s . So that, the current through the resonant inductor cannot be commutated. Thus, the zero voltage vector of three-phase inverter treated here uses the method (see Fig. 7) of outputting the same interval as the specified time of switching space voltage vector toward the opposite direction mutually on a α - β stationary coordinates plane.

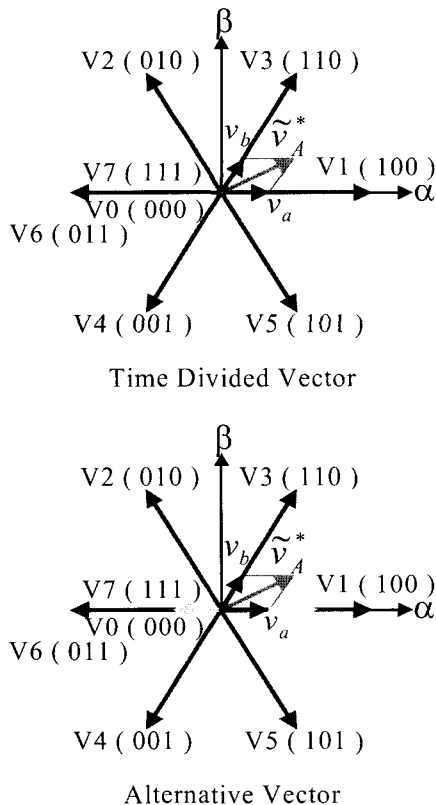

Fig. 7. Sampling time divided vector method.

5. Simulation Results and Discussions

For the three-phase power module bridge package type auxiliary resonant AC link snubber-assisted three-phase voltage type sinewave soft switching PWM inverter using IGBTs, the output voltage and the output current operating waveforms are illustrated in Fig. 8. This simulation software of the three-phase soft switching inverter treated here is automatically designed so as to stop the simulation processing for operating at the hard switching PWM mode.

The operation waveforms in the steady-state are considered under soft switching PWM commutation by making use of the simulation based on the state variable analysis approach. All the main power switches and the auxiliary power switches can output the sinewave voltage under the conditions of the soft switching PWM operation. The sampling frequency is determined by $f_s=20[\text{kHz}]$ from an acoustic noise point of view, a dead time is $t_d=1.5[\mu\text{s}]$ in design. The simulations of the three-phase hard switching sinewave PWM inverter also similarly carried out as compared with those of the three-phase soft switching sinewave PWM inverter. The total harmonic distortion factor (THD) of the output voltage waveform in simulation is represented in Table 3 for resistive and inductive balanced three-phase loads. It is noted that the design specifications and circuit parameters of the three-phase inverter treated here can be indicated.

6. Efficiency Evaluations Under Measured Characteristic Data

In general, the power losses in the three-phase sinewave soft switching PWM inverter circuit is characterized as follows,

- Conduction loss by the effective resistance component of the resonant inductor
- Conduction loss by all the power semiconductor devices of the active power switches; IGBTs and the passive power switches; diodes
- The switching power loss in the switching transient state of the power devices; IGBTs and diodes.
- The conduction power loss by the LC low pass filter of three-phase voltage source type sinewave PWM inverter.

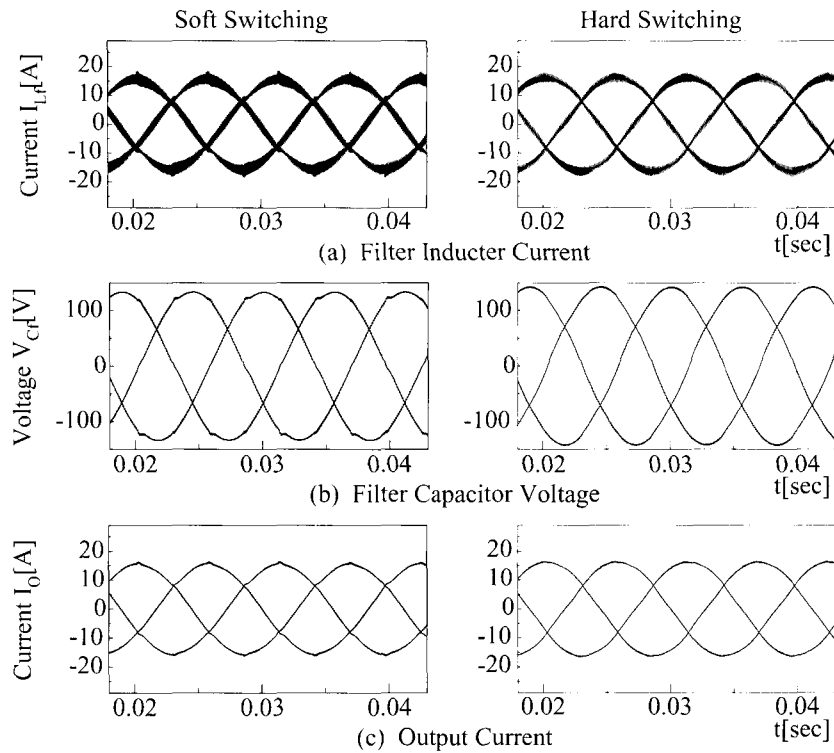

Fig. 8. Simulation output voltage and current waveforms.

Table 3. Comparative THD characteristics between H-SW and S-SW PWM inverters.

Load types	Switching scheme	THD[%]
Resistive loads	H-SW	1.77
	S-SW	2.56
Inductive loads	H-SW	2.03
	S-SW	3.54

Remarks : Hard switching H-SW ; Soft switching S-SW

The power losses by the resonant inductor of the conditions (a) and (d) mentioned above are determined for the internal dc resistance component of the resonant inductor. Both the conditions (b) and (c) mentioned above are based on the measured v-i characteristics in experiment. IGBTs and diodes in the three-phase soft switching PWM inverter as well as the three-phase power module bridge package type auxiliary resonant AC link snubber are assumed to be the same voltage and current ratings.

The IGBTs uses the measured v-i characteristics data of CM100DU-12F. Then, the characteristic curve approxi-

-ation of power semiconductor switching devices is introduced in the simulation program, and the conduction power losses of the power semiconductor devices IGBTs are determined numerically. The current through the antiparallel diode is larger than 10[A], and in 50[A] or less, the equation of the v-i characteristics could be specified by;

$$V_{on} = -0.0103 \cdot i_{Diode} + 0.8175 \text{ [V]} \quad (1)$$

The current through the antiparallel diode is larger than 0[A], and within 20[A] or less, the approximate equation of the v-i characteristics is as follow;

$$V_{on} = -0.042 \cdot i_{Diode} + 0.4996 \text{ [V]} \quad (2)$$

The current through the IGBT and the antiparallel diode are 0[A], the equation of the v-i characteristics is given by;

$$V_{on} = 0.0 \text{ [V]} \quad (3)$$

The current through the IGBT is larger than 0[A], and in 20[A] or less, the equation of the v-i characteristics is expressed by;

$$V_{on} = 0.025 \cdot i_{IGBT} + 0.4997 \text{ [V]} \quad (4)$$

The current through the IGBT is larger than 20[A], and in 50[A] or less, the equation of the v-i characteristics is specified by;

$$V_{on} = 0.0077 \cdot i_{IGBT} + 0.8467 \text{ [V]} \quad (5)$$

where, i_{IGBT} is the instantaneous current flowing through the IGBT, and i_{Diode} is the instantaneous current flowing through the antiparallel diode.

Once the diode turns on, and then, the collector current flows through IGBTs. Therefore, the turn-on switching power loss does not exist almost in principle. The turn-off switching power losses are required for the switching losses in the turn-off transient current of IGBT. The switching power losses are similar to the following equation.

$$loss_{Turn_off} = 0.0343 \cdot i_{IGBT}^{0.6} \text{ [mJ]} \quad (6)$$

The simulation treated here is based on algorithm, which calculates the instantaneous switching power losses in every turn-off instant.

Fig. 9 represents the results of the power loss analysis

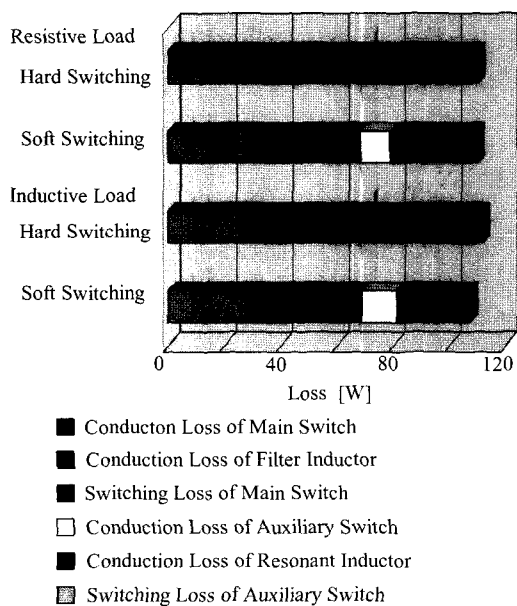

Fig. 9. Power loss analysis.

for the soft switching inverter when employing the measured losses data relating to the v-i characteristics, the switching characteristics of IGBTs is incorporated into the computer simulation program. The main power losses of a three-phase voltage type sinewave hard switching PWM inverter are mainly the conduction power loss of each main power switch, the conduction power loss of a low pass filter, and the switching power loss of the main power switch. Although the switching power losses of the main power switches in three-phase voltage type sinewave soft switching PWM inverter with three-phase power module bridge package type resonant AC link snubber could reduce over 50% as compared with those of three-phase hard switching PWM inverter. But soft switching inverter has the power losses (conduction loss of an auxiliary power switch, the switching power loss of an auxiliary power switch, the conduction power loss of resonant inductor) in an auxiliary resonant AC link snubber circuit part. Still the total power loss in three-phase voltage type sinewave soft switching PWM inverter using IGBTs is smaller than power loss estimation of total power loss in three-phase hard switching inverter using IGBTs.

The conventional efficiency of a three-phase hard switching inverter is 94.78 [%]. On the other hand, it is noted that the conventional efficiency of a soft switching inverter is 94.79 [%]. Moreover, three-phase soft switching PWM inverter could be effectively put into practice for new energy interfaced distribution power supplies. The power rating of this experimental breadboard set up is specified to 2kW, which is designed for a small scale power applications. When a rating output power is 10kW or more, the power losses of the main circuit components are larger than power losses of an auxiliary resonant AC link snubber circuit component. Therefore, if the output power becomes high, the conventional power conversion efficiency of the three-phase soft switching PWM inverter operating under effectively becomes much higher than the efficiency of hard switching inverter.

7. Conclusions

In this paper, the operation principle of a bidirectional switch type resonant AC link snubber circuit was

described, together with its practical circuit design procedure, which incorporates the proposed three-phase power module bridge package type resonant AC link snubber. The novel prototype of power module bridge package type resonant AC link snubber-assisted three-phase voltage source sinewave soft switching PWM inverter using IGBT power modules was demonstrated herein. It was verified that both the auxiliary power switches in this resonant AC link snubber circuit and the main power switches can commute under the condition of soft switching commutation principle. The specific instantaneous space voltage vector modulation was pointed out of this new inverter. It was indicated that the output voltage THD of three-phase voltage type sinewave soft switching PWM inverter with the maximum time $5.0[\mu\text{s}]$ during operating period is evaluated, which is almost equivalent to the output voltage THD of three-phase hard switching inverter with dead time $1.5[\mu\text{s}]$.

It was noted that the power loss analysis can be actually performed, considering the v-i characteristics and switching loss characteristics of IGBTs. It was proven that a three-phase voltage source type soft switching PWM inverter treated here was made to be high efficiency. Furthermore, the practical power losses of the new soft switching inverter treated here were analyzed by implementing the experimental data of the IGBT and diode v-i characteristics in addition to switching power loss characteristics into our original computer simulation software developed by the authors. Then, three-phase voltage type soft switching PWM inverter was high efficiency as well as those of three-phase hard switching inverter, along with performance operation waveforms.

The three-phase auxiliary resonant AC link snubber-assisted soft switching PWM inverter using IGBT power modules could be sufficiently put into practice by comparing three-phase hard switching PWM inverter with three-phase soft switching inverter.

In the future, the comparative feasibility study of three-phase power module bridge type resonant AC link snubber and its related soft switching inverter in addition to the other types resonant snubber assisted soft switching inverter should be experimentally done from a practical point of view.

References

- [1] Young-Chae Jung, Gyu-Hyeong Cho: "Low-Loss Quasi-Parallel Resonant DC Link Inverter with Advanced PWM Capability" *International Journal of Electronics*, Vol. 81, No. 2, pp. 219-234, 1996.
- [2] M.Kurokawa, Y.Konishi, M.Nakaoka: "Evaluations of Voltage-Source Soft-Switching Inverter with Single Auxiliary Resonant Snubber" *IEE-UK Transactions on Electric Power Applications*, *IEE-UK Transactions on Electric Power Applications*, Vol. 148, No. 2, pp. 207-213, Mar. 2001.
- [3] J.S.Lai, R.W.Young, G.W.Ott, Jr., J. W.McKeever, F.Z.Peng: "A Delta-Configured Auxiliary Resonant Snubber Inverter" *Proceedings of IEEE Applied Power Electronics Conference (APEC)*, Vol. 2, pp. 797-803, Mar. 1995.
- [4] S.R.Lee: "A Control Strategy of The Three-Phase Bridge-Type ZVT Inverter for AC Motor Drives" *Proceedings of International Conference on Power Electronics (ICPE) Seoul*, pp. 529-534 Oct. 1998.
- [5] S.R.Lee, C.H.Jeon, S.H.Ko: "A New Current Controlled Inverter with ZVT Switching" *Proceedings of International Conference on Power Electronics (ICPE) Seoul*, pp.309-313 Oct. 2001.
- [6] J.S.Lai, "Practical Design Methodology of Auxiliary Resonant Snubber Inverter", *Proceedings of IEEE Power Electronics Specialists Conference (PESC)*, Vol. 2, pp. 432-437, June. 1996.
- [7] S.Hoshi, K.Oguchi: "Considerations on control Strategy and Efficiency of Three-Phase Resonant Snubber Inverter", *The paper of Technical Meeting on Semiconductor Power Converter (SPC) IEE-Japan*, SPC-00-88, pp. 72-82, Nov. 2000.
- [8] M.Yoshida, E.Hiraki, M.Nakaoka,: "Operating Evaluations of Three-Phase Voltage Source Soft Switching Inverter with A Single Commutation Type Resonant AC Link Snubber" *Proceedings of IEE-Japan International Power Electronics Conference (IPEC)-Tokyo 2000*, Vol. 4, pp. 1755-1759, Apr. 2000.
- [9] S.Nagai, S.Sato: "Resonant Three Phase Inverter" *Proceedings of IEE-Japan Industry Application Annual Meeting*, Vol. 2 pp. 1365-1368, Aug. 2001.



Hisashi Iyomori received the B. Eng. degree from Department of Electrical and Electronics Engineering, Yamaguchi University, Yamaguchi, Japan, in 2002, and the M.Eng. degree from Division of Electrical and Electronics Engineering in 2004. He is working for Mitsubishi Electric Co., Ltd., Fukuoka, Japan. His research interest includes the soft-switching power electronics for high frequency switching power conversion circuits and systems. He got the Best Presentation certification at 2003 IEEE-IECON Virginia USA. Mr. Iyomori is presently a member of the IEE-Japan, the Japan Institute of Power Electronics, and the IEEE-USA.

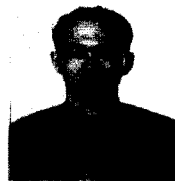

Shin-ichiro Nagai received his B.Sc.-Eng in Mechanical Engineering from Aoyama University, Tokyo, Japan, in 1995, and the Dr.Eng. degree from Division of Systems Engineering, the Graduate School of Science and Engineering, Yamaguchi University, Yamaguchi Japan, in 2004. He joined for a research member in R&D of Sanken Electric Co., Ltd., Saitama, Japan. He is interested in the new developments of soft switching inverter and rectifier systems, wind power generator, fuel cell and solar PV power conditioner systems and their related digital control systems. He is a member of the Japan Society of the Power Electronics, IEE-J and IEEE-USA.



Masanobu Yoshida received the B. Eng. degree from Department of Electrical and Electronics Engineering, Yamaguchi University, Yamaguchi, Japan, in 1999, and the M.Eng. degree from Division of Electrical and Electronics Engineering, Yamaguchi University, Yamaguchi, Japan, in 2001, and the Dr.Eng. degree from Division of Systems Engineering, the Graduate School of Science and Engineering Yamaguchi University, Yamaguchi Japan, in 2004. He is presently working as Research Associate in Kochi National College of Technology, Kochi, Japan. His research interest includes the soft-switching related hardware and software development for high frequency switching power conversion systems. He is a member of the IEE-Japan, the Japan Institute of Power Electronics, and the IEEE-USA.



Eiji Hiraki received the Dr. Eng. degree from the Graduate School of Engineering Science Osaka University, Japan. He joined the Technological Research Institute of Mazda, Co. Ltd. He is currently with the Power Electronic and Control System Engineering Laboratory (Nakaoka Lab.) at the Department of Electrical and Electronics Engineering, Yamaguchi University, Yamaguchi, Japan, as a research associate. His research interest includes soft-switching control software and hardware techniques for high frequency switching power conversion circuit and energy systems as well as generic power electronic simulator developments. He is a member of the Institute of Electrical Engineers of Japan, the Japan Society of Power Electronics, the Institute of Electronics, Information and Communication Engineers of Japan and the IEEE-USA.



Mutsuo Nakaoka received his Dr-Eng. degree in Electrical Engineering from the Graduate School of Engineering, Osaka University, Osaka, Japan in 1981. He joined the Electrical and Electronics Engineering Department of Kobe University, Kobe, Japan in 1981. Since 1995, he has been a professor of the Electrical and Electronics Engineering Department, the Graduate School of Science and Engineering, Yamaguchi University, Yamaguchi, Japan. His research interests include application developments of power electronics circuit and systems. He got the 2001 IEE-UK premium paper prize award and the 2003 IEEE-IAS James Melcher paper prize award and so forth. Dr-Eng Nakaoka is a member of the Institute of Electronics, Information and Communication Engineers of Japan, Institute of Illumination Engineering of Japan, European Power Electronics Association (EPE), the Japan Society of the Solar Energy, IEE-Korea and IEEE.