

A Human Robot Interactive System "RoJi"

Joongsun Yoon*

School of Mechanical Engineering, Pusan National University, Pusan 609-735, Korea

A human-friendly interactive system that is based on the harmonious symbiotic coexistence of human and robots is explored. Based on interactive technology paradigm, a robotic cane is proposed for blind or visually impaired travelers to navigate safely and quickly through obstacles and other hazards faced by blind pedestrians. Robotic aids, such as robotic canes, require cooperation between human and robots. Various methods for implementing the appropriate cooperative recognition, planning, and acting, have been investigated. The issues discussed include the interaction between humans and robots, design issues of an interactive robotic cane, and behavior arbitration methodologies for navigation planning.

Key Words : Human-Robot Interaction, Interactive Technology, Robotic Cane, Shared Behavior Control

1. Introduction

Robotic aids, used widely in areas such as health care and home assistance, require cooperation between humans and robots. The proper control commands for such systems would be a combination of autonomous commands from robots and commands from human, rather than either autonomous commands or solely human commands (Shim, 2003 ; Aigner and McCarragher, 1999 ; Lacy and Dawson-Howe, 1999).

This paper explores a human-friendly interactive system, based on the harmonious symbiotic coexistence of humans and robots. A robotic cane is an interesting and excellent media to explore various aspects of human-robot interactions. It opens up the possibilities for truly human-friendly machines. Firstly, the cane is an extension of the human body like a tool at the hand during the stone age, where the users' intentions and close interactions can be investigated. Secondly, if intelligence is all about interaction and doing the right thing in the real world, then sensing is what

allows robots to do intelligent things. As human sensing is dominated by sight, it is interesting to see what happens if sight is impaired and how robots can work things out together with human partners (Aylett, 2002 ; Shim, 2003 ; Yoon, 2003).

Our goal is to develop a robotic aid system capable of interacting with its environment and eventually with human. Various methods for implementing the appropriate cooperative recognition, planning, and acting have been investigated (Shim, 2003 ; Yoon, 2003 ; Yoon et al, 2000).

We outline a set of hardware solutions and working methodologies that can be used for successfully implementing and extending the interactive technology to coordinate human and robots in complicated and unstructured environments. The issues discussed include methodologies for human-robot interactions, design issues of an interactive robotic cane, hardware requirements for efficient human-robot interactions, and behavior arbitration methodologies for navigation planning.

2. Hardware Configuration of Robotic Cane "RoJi"

The successfully and widely used travel aids for the blind are the white cane and the guide dog.

* E-mail : jsoon@pnu.edu

TEL : +82-51-510-2456; FAX : +82-51-510-3084

School of Mechanical Engineering, Pusan National University, Pusan 609-735, Korea. (Manuscript Received November 19, 2003; Revised July 16, 2004)

Electronic travel aids are also used, but not so widely. By taking advantage of the white cane and the guide dog, we have been developing a robotic aid system named "RoJi" as shown in Figs. 1~2 and its specifications are summarized in Table 1 (Shim, 2003 ; Shim and Yoon, 2003 ; Shoal et al, 2003).

The proposed robotic cane, "RoJi," consists of a long handle, two steerable wheels, a sensor unit

that is attached at the distal end of the handle, and an user interface panel. Much like the widely used white cane, the user holds these robotic canes in front of him/her while walking. The handle is painted in white to mimic the white cane. The sensor head, which is mounted on a steerable, powered, two-wheeled steering axle, includes three infrared sensors, two antenna type contact sensors, and a sonic scanner.

The robotic cane named "RoJi," makes independent decisions concerning the path it takes. However, the user and the cane may wish to go in different directions. The normal operating mode of the constructed robotic cane must include an override feature to allow the blind person to be in control when the need arises. We have tried to build a system that is capable of interacting with its environment and eventually with humans.

The contents of the robotic cane system and how these components are used to provide desired functional capabilities are described.

Table 1 Specification of "RoJi"

Gross mass	5.8 kg
Diameter of body	36 cm
Height	20 cm
Cane length	100 cm
Battery	12 Volt
Cover material	Transparent acryl
Degree of mobility	2
Radius of wheel	6 cm
Encoder resolution	3.78 cm/pulse
Maximum speed	37 cm/sec

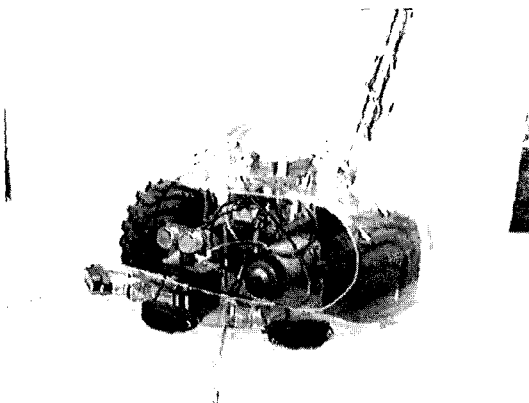

Fig. 1 An interactive robotic cane "RoJi"

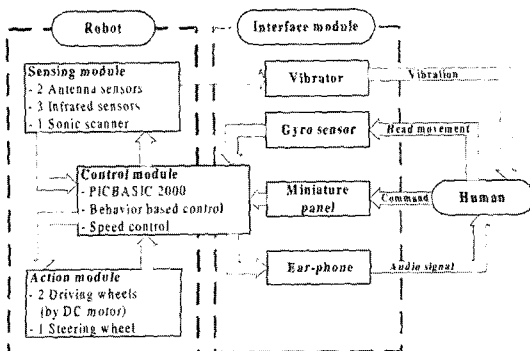

Fig. 2 Configuration of "RoJi"

2.1 Control module and action module

"RoJi" utilizes an on-board PICBASIC 2000 microcontroller to process the sensor information and the timer counts, and also to generate control pulses for the DC servo motor. The PICBASIC 2000 can be easily programmed in Basic with the built-in analog and digital interface functions. The μ -controller is connected to thirty-two digital inputs/outputs, two PWM (pulse width modulation) outputs, one high-speed pulse counter, eight 10-bit A/D (analog-to-digital) inputs and a 64 Kbytes flash memory (COMFILE Technology, 2000).

"RoJi" is driven and steered by two powered motors. By this way, it can guide the blind person autonomously with sufficient power. The two front-steering wheels of the cane are controlled independently by separate DC motors. One un-powered wheel in the back stabilizes the cane's stable structure and produces sharper turns.

2.2 Sensing module

"RoJi" has a sensing module that is attached at the distal end of the handle to detect obstacles. This sensing module consists of an active ultra-

sonic sensor unit, three infrared sensors, and two antennas for contact sensing. A sensing module, as shown in Fig. 3, is mounted above the guide wheels of "RoJi." The sensing module mounted above the guide wheels has an ultrasonic sensor driven by a RC motor, as shown in Fig. 3. The module scans the area ahead of it to efficiently detect obstacles or safe paths and can reduce the missing areas caused by the narrow coverage due to the fixed sensor arrangement. Its scanning angle is $\pm 90^\circ$ wide. The ultrasonic sensor detects any obstacle up to a distance of 250 cm and within a range of $\pm 30^\circ$.

An array of three infrared sensors is utilized to detect the convex obstacles blocking the cane's pathway. These three sensors are arranged in a semi-circular fashion, 30° apart from each other, and can detect any obstacle within a distance of 60 cm. This arrangement is based on the user's shoulder width. Including the size of the robot platform with the radius of 18 cm, we can assure a safe pathway up to approximately 80 cm wide.

For short-range coverage, additional antennas for contact sensing could effectively complement these infrared sensors and the active sensing unit. Limit switches, angle detectors, or torque sensors attached to these antennas quickly and easily detect dynamic changes in the environment when the potentiometers contact a surface or a bend. Limit switches were utilized in the earlier prototype of robotic canes. In place of these, potentiometers are utilized for "RoJi." Each antenna is arranged between the infrared sensors. It must be

made of flexible materials so as not to interfere with navigation when it touches the surface to detect obstacles. Steel was selected for "RoJi," and the length of each antenna is 22 cm. These antennas are connected to the potentiometer to detect sudden irregularities of the surface and to react appropriately to them. Antennas are especially suitable to take advantage of the visually impaired people's superb tactile information processing capabilities (Shim 2003).

2.3 Operator interface module

A miniature panel that can be operated with the thumb allows a user to specify a desired direction of motion, as shown in Fig. 4(a). This operator interface module also lets the user and the cane share information to cooperate with and compensate for each other. The user receives the cane's obstacle information as different tones of

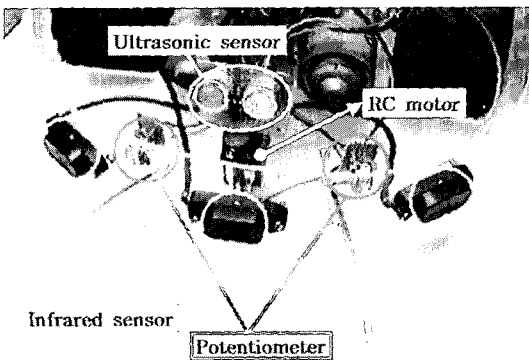
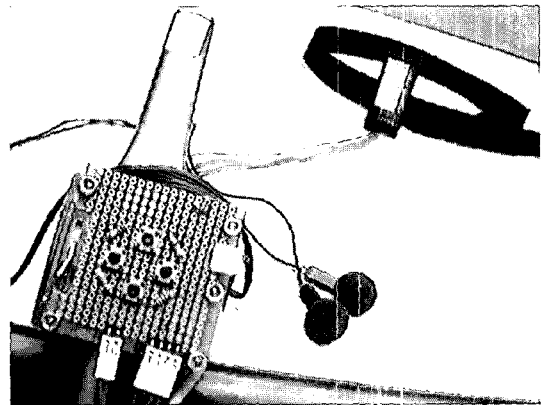
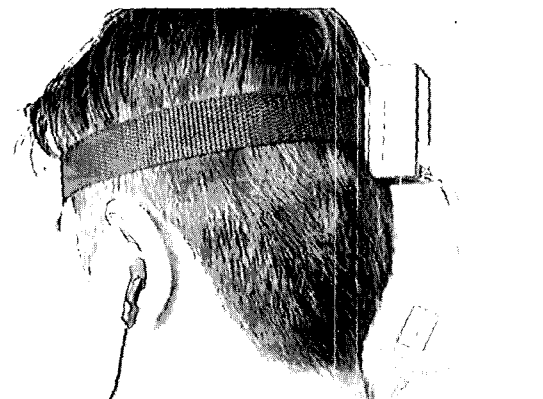

Fig. 3 Sensors for "RoJi"



(a) A miniature user-interface panel



(b) Gyroscope sensor for head tracking

Fig. 4 User interface for "RoJi"

audio signals proportional to the distance and triggers the proper navigation command buttons.

The user can point the active sensing unit to his or her viewing direction. The active sensing unit of "RoJi," as shown in Fig. 4(b), can track the user's head movements by utilizing a gyroscope sensor attached to his/her head. A semiconductor-type gyroscope, muRata's ENV-05S, is utilized (muRata, 1996).

Users can recognize the distance and the direction of the obstacles based on audio and gyroscope information. Once the navigation path is determined, the user can control the robotic cane by pressing the buttons on the interface panel. The operator interface module contains four command buttons: "Go Straight," "Turn Left," "Turn Right," and "Stop." A small motor attached to the panel vibrates back to the user, depending on the ground information, e.g. distance level to the obstacles. Also, speakers carry alarm sounds to alert the user. The cane benefits from the user's flexible decision capabilities and his/her tactile and auditory information processing capabilities.

3. Control Algorithm of "RoJi"

3.1 Shared navigation planning

Pedestrians usually detect obstacles and navigate properly based on visual information. The user's decisions for proper navigation are based on the user's a-priori, intuitive and heuristic mental processing, instead of precise computations. In contrast, mobile robots' lack of intuitive nature requires precise geometric information about the obstacles and goals. A blind or visually impaired traveler with a white cane and/or a guide dog only require approximate geometric information about the obstacles and goals.

Robotic aids, such as robotic canes, require cooperation between humans and robots. The constructed robotic cane is self-steering, based upon the interpretation of its input. The steering command of the robotic cane is based on the absence or presence of obstacles sensed by photo sensors. Without a shared control framework in place, the cane would want to avoid objects such

as stairs, doors, or chairs that the user might want to use. The operator's decision making must be included. Clearly the normal operating mode of the robotic cane must be overridden to allow the person to be in control when the need arises.

The proper control commands for such a system would be a combination of autonomous commands and commands from humans, rather than either autonomous commands or solely human commands. Our robotic cane has two control modes, the robot control mode (RCM) and the user control mode (UCM). This shared control framework is as shown in Figs. 5~6 (Shim, 2003).

The cane's navigation control allows the robot to detect the obstacles and navigate safely and quickly based on the robot's autonomous commands and the user's input commands. User can initiate the RCM or the UCM by switching a navigation mode button. The cane's RCM is an extended autonomous navigation mode, which includes the user's intention. The traditional autonomous navigation mode can be described as a flow with bold outline as shown in Fig. 5 (Arkin, 1998; Park, 2003; Park, 2002). The cane's UCM allows the user to navigate safely when the cane and the user make conflicting and/or difficult decisions to follow.

3.2 Robot control mode

The robot control mode (RCM) contains three different behavior modes: "Follow Human Or-

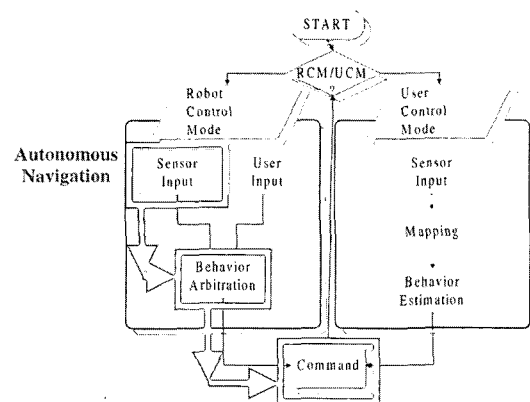

Fig. 5 Control flow of "RoJi"

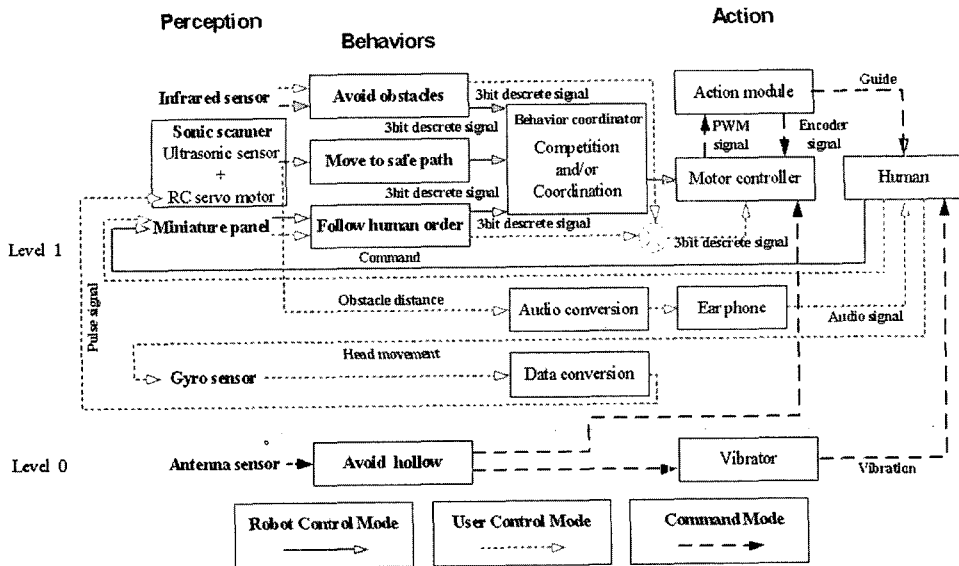

Fig. 6 Control architecture of "RoJi"

der," "Avoid the Obstacles," and "Move to Safe Path." The first behavior mode, "Follow Human Order," determines the navigation direction based on the user's intention. The cane performs the same actions as the user's commands: "Go Straight," "Turn Left," and "Turn Right." The second behavior mode, "Move to Safe Path," determines the navigation direction for a safe path. The active sonar scans the area ahead of it from left to right to decide the safe path direction that is furthest direction from the obstacles. The cane navigates following such directions. Considering the detection range of the ultrasonic sensor, the area is divided into three zones. The scanning period is 1 sec. The safe path is set to be the latest zone detected when the distance from the obstacle for each scanning direction is the same or further than the maximum detection range of 250 cm. When the sensing module scans the area ahead of it and the left zone has the maximum possibility avoidance, the cane turns left and follows the corresponding path.

The third behavior, "Avoid the Obstacles," determines the navigation direction by moving around obstacles. The RCM models the possible infrared sensor states, S1 or S0. S1 and S0 represent the presence and the absence of a detected obstacle, respectively. With an array of three

sensors, the RCM of the robotic cane represents eight possible states. Additional sensors could be utilized to plan different obstacle-avoidance strategies. State changes in the RCM are triggered by sensor events at each discrete time interval. To avoid colliding with obstacles, the RCM generates controller events in the form of a discrete representation of the desired turning angle.

The output of each behavior is channeled into a coordination mechanism that consists of logic operators. The coordinator produces an appropriate overall motor response for the robotic cane at any point in time, given current existing environmental stimuli including human orders. Through coordination and competition of behaviors, the coordination module arbitrates proper behaviors to produce an appropriate overall motor response. The RCM, described as a stimulus-response diagram, is as shown Fig. 7 (Arkin, 1998 ; Shim, 2003 ; Shim and Yoon, 2003).

The earlier version of navigation planning was based on a table lookup method. The navigation rules are tabulated and the cane performs navigation following these rules. Each behavior is represented by a 3-bit discrete signal. The first behavior includes three user's commands. The second behavior includes three directions of safe path. The third behavior includes seven states

of sensors. The possible number of navigation rules is 36. This rule-based method suffers from programming inefficiencies when the behaviors get increased due to the nature of constructing the corresponding rules (Shim, 2003 ; Shim and Yoon, 2003).

As an alternative method, a heuristic behavior arbitration method based on logic operator has been proposed shown in Fig. 8. The behavior arbitration procedure is as follows. A "NOT" operation flips the digital signals of the first behavior and the second behavior. This confirms the stimulus condition for the third behavior. An "AND" operation finds a common stimulus for the first behavior and the second behavior. This common stimulus can be a virtual obstacle. An "OR" operation applies the presence of both real obstacles and a virtual obstacle. When the output status of the coordinator is [0 1 0], the user input overrides the autonomous command. Otherwise, the autonomous commands are performed (Shim, 2003 ; Shim and Yoon, 2003).

The construction of a behavior coordinator, based on this trial and error method, becomes extremely difficult when robot systems and behaviors are more complicated. We can overcome this problem by applying an evolutionary approach to construct behavior coordinator in automatic and efficient ways.

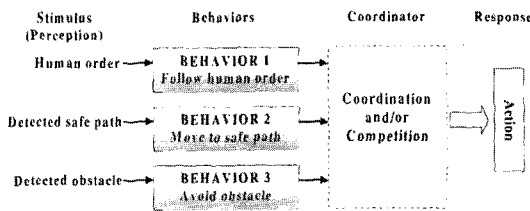

Fig. 7 Stimulus-response diagram for "RoJi"

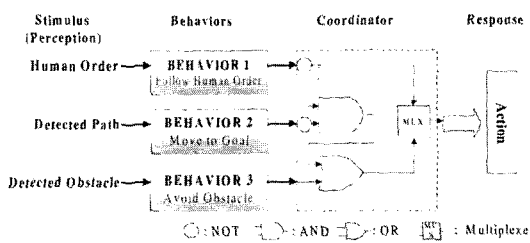

Fig. 8 A heuristic navigation strategy coordinator

Each behavior is represented by a 3-bit discrete signal. The behavior coordinator can be constructed as a combination of logic operators. A gene representing each logic operator consists of two or three inputs to a logic operator, a type of logic operator, and one output from a logic operator, as shown in Fig. 9. The multiplex has three input connections and all the other logic operators have two input connections. Allowed logic operators: AND, OR, MUX, NAND, NOR, XOR are numbered as 1 to 6, respectively (Shim, 2003 ; Shim and Yoon, 2003).

The evolution algorithm used to evolve the behavior coordinator is a simple form of $(1+\lambda)$ evolutionary strategy, where λ is 5. The maximum number of logic operators has been set to 15 for computational efficiency. The maximum number of generation is set to 10,000. The mutation rate is 20%, i.e. 3 out of 15 logic operators. The lookup table presents a guideline for the proper actions a robotic cane can take. Fitness can be evaluated counting matching rules from this table. An evolved behavior coordinator of "RoJi" is as shown in Fig. 10 (Negnevitsky, 2002 ; Shim, 2003).

3.3 User control mode

In the UCM, the user operates the robot direct-

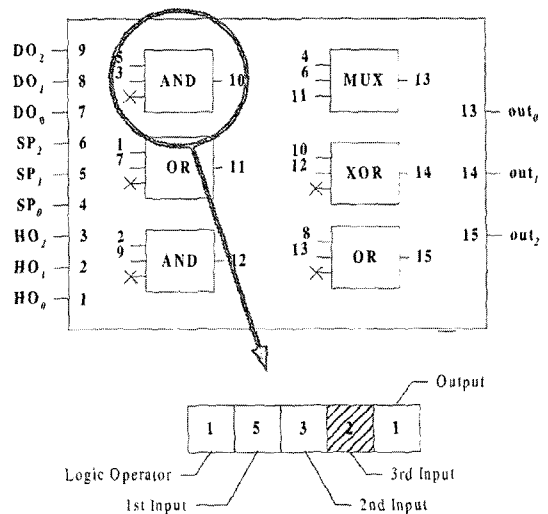

Fig. 9 Phenotype and genotype of behavior coordinator with logic operator

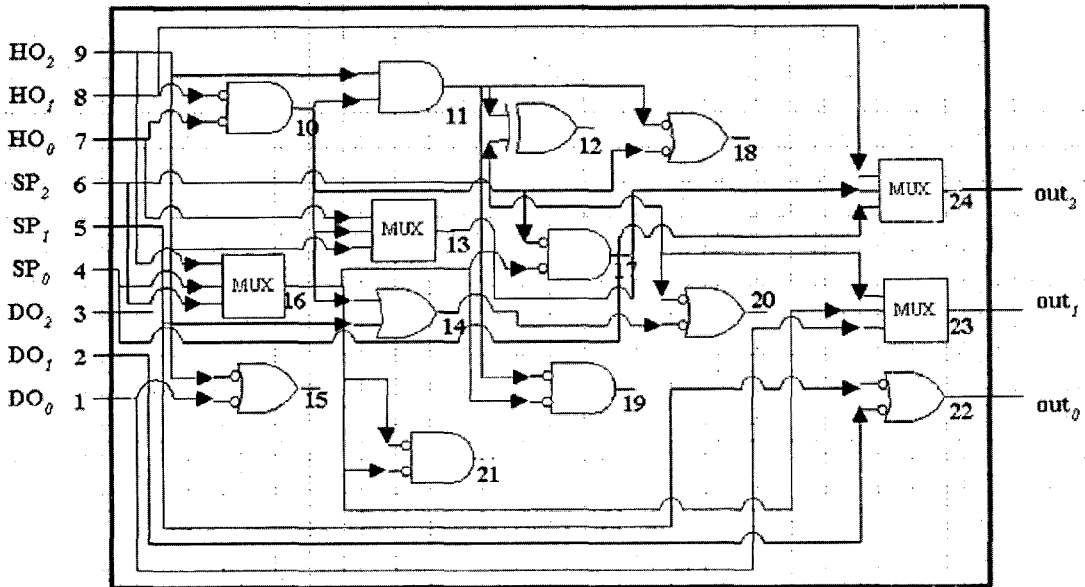

Fig. 10 An evolved behavior coordinator of "RoJi"

ly based on the information that can be recognized by a blind person, such as auditory information. The robot provides the user with auditory information as converting visual information that is obtained by sensors into sound. The blind user receives the cane's obstacle information and the cane benefits from the user's flexible decision-making capabilities and his/her tactile and auditory information processing capabilities.

The user can point the active sensing unit of the robotic cane in user's viewing direction. The active sensing unit of "RoJi" can track the user's head movements by utilizing a gyroscopic sensor attached to the user's head. The robotic cane provides the user with auditory information as converting visual information, which is obtained by sensors, into sound. Also, speakers carry alarm sounds to alert the user.

User can recognize the distance and the direction of the obstacles combining the gyroscope/audio information from the cane and the auditory/tactile information from the user. Once the navigation path is determined, the user can control the robotic cane by pressing the buttons on the interface panel.

4. Implementation

Figure 11 shows two autonomous operations of the robotic cane for avoiding two obstacles and guiding the user to a safe path when the user command is "Go Straight" and "Turn Left." Two cubic objects are 21 cm (L) × 30 cm (W) × 25 cm (H) and 60 cm (L) × 20 cm (W) × 60 cm (H). In both cases, the robotic cane avoided these obstacles and returned to the original course of the user.

Figure 12 shows two operations of the robotic cane for avoiding both complicated and unexpected dynamic obstacles, and guiding the user to a safe path. In the first navigation experiment, the cane navigates around the chair in shallow and complicated shapes. In the second navigation experiment, the robotic cane avoided the sudden approaches of human pedestrians and returned to the original course of the user.

Four shared navigation experiments, as shown in Fig. 11 and Fig. 12, demonstrate efficiencies of the "RoJi." These tests show the cane's good performance on flat surface. If we make cane small enough to lift, it can fit into more diverse

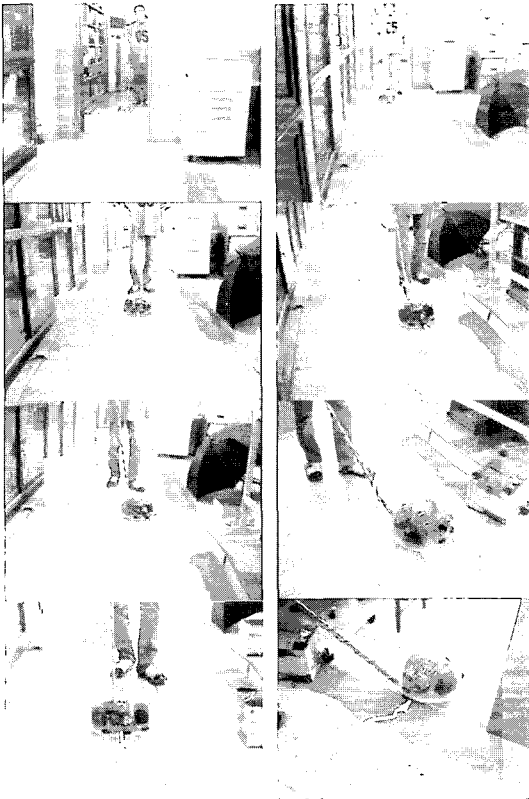

Fig. 11 Navigation of "RoJi" under static obstacles

user environments, such as uneven surfaces like stairs.

5. Summary

A human robot interactive system was explored. Based on interactive technology, a robotic cane, "RoJi," is proposed for blind or visually impaired travelers to navigate safely and quickly among obstacles and other hazards faced by blind pedestrians. Unique features of our robotic cane include an active sensing unit, antennas for contact sensing, powered wheels, and a customized-off-the-shelf (COTS) design.

The ultrasonic sensor in this active sensing unit can detect the obstacles of the safe paths efficiently by scanning the area ahead by a RC motor. It can reduce the missing areas caused by the narrow coverage due to the fixed sensor arrange-

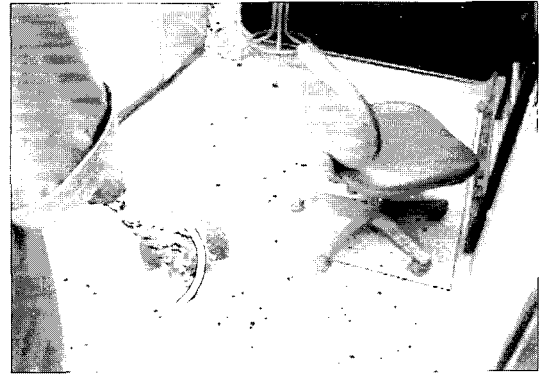

(a) Complicated obstacles



(b) Dynamic obstacles

Fig. 12 Navigation of "RoJi" under special obstacles

ment. Additional antennas for contact sensing effectively compensate mid-range and/or long-distance sensing. Antennas are especially suitable for the blind user's superb tactile information processing capabilities.

Four shared navigation experiments demonstrate the efficiency of the "RoJi" on flat surface. To evaluate performance of the interactive cane, we need a more realistic working model for the handicapped. If we make the cane small enough to lift, it can fit into more diverse user environments, such as uneven surfaces like stairs. To obtain substantial physical results, we are currently working on theoretical backgrounds regarding emotions and human-robot interactions issues (Norman, 2004 ; Yoon et al., 2004a ; Yoon et al., 2004b).

Our robotic cane is operated based on a shared control approach, which contains the robot con-

trol mode (RCM) and the user control mode (UCM). The RCM is implemented by a lookup table and a heuristic logic operator. As the number of behavior increases and the system becomes more complicated, it will become difficult to find an appropriate coordinator for behavior arbitration. We are currently investigating an easy way to evolve coordinator's elements based on an evolutionary engineering approach (Lee et al., 2003; Shim and Yoon, 2002; Son and Yoon, 2000). The UCM is implemented by the user's heuristic decision-making capabilities. The UCM allows the cane and the user to share geometric information about their environment and navigate following the user's operation.

References

- Aigner, P. and McCarragher, B., 1999, "Shared Control Framework Applied To a Robotic Aid for the Blind," *IEEE Control Systems Magazine*, Vol. 19, No. 2, pp. 40~46.
- Arkin, R., 1998, *Behavior-based Robotics*, The MIT Press, Cambridge.
- Aylett, R., 2002, *Robots : Bringing Intelligent Machines To Life?*, Baron's, Hauppauge.
- COMFILE Technology, 2000, *PICBASIC2000 DATA BOOK*, COMFILE Technology, Seoul.
- Lacey, G. and Dawson-Howe, K., 1999, "The Application of Robotics to a Mobility Aid for the Elderly Blind," *Robotics and Autonomous Systems*, Vol. 23, pp. 245~252.
- Lee, J., Shim, I. and Yoon, J., 2003, "Realtime Evolutionary Learning of Mobile Robot Behaviors," *Proceedings of the 2003 Spring Annual Meeting of Korean Society of Mechanical Engineering*, (in Korea).
- muRata, 1996, "Piezoelectric Vibrating Gyroscopes: Gyrostar® ENV," Available <http://www.avnet.se/avnettimes/september96/murata.html>.
- Negnevitsky, M., 2002, *Artificial Intelligence: A Guide to Intelligent Systems*, Addison-Wesley, San Francisco.
- Norman, D. A., 2004, *Emotional Design : Why We Love (or Hate) Everyday Things*, Basic Books, New York.
- Park, K. H., Kim, H. O., Baek, M. Y. and Kee, C. D., 2003, "Multi-Range Approach of Stereo Vision for Mobile Robot Navigation in Uncertain Environments," *KSME International Journal*, Vol. 17, No. 10, pp. 1411~1422.
- Park, T. J., Ahn, J. W. and Han, C. S., 2002, "A Path Generation Algorithm of an Automatic Guided Vehicle Using Sensor Scanning Method," *KSME International Journal*, Vol. 16, No. 2, pp. 137~146.
- Shim, I., 2003, "Interactive Robotic Cane," Master Thesis, Pusan National University, Pusan, (in Korea).
- Shim, I. and Yoon, J., 2003, "A Human Robot Interactive System "RoJi"," *Proceedings of the AIM2003*, Vol. 2, pp. 723~728.
- Shim, I. and Yoon, J., 2002, "Evolutionary Learning of Mobile Robot Behaviors," *Proceedings of KFIS Fall Conference 2002*, Vol. 12, No. 2, pp. 207~210, (in Korea).
- Shoval, S, Ulrich, I. and Borenstein, J., 2003, "NavBelt and the GuideCane," *IEEE Robotics and Automation Magazine*, Vol. 10, No. 1, pp. 9~20.
- Son, H. and Yoon, J., 2000, "Evolving Neural Network for Realtime Learning Control," *Proceedings of 15th KACC*, (in Korea).
- Yoon, J., Yoh, M. and Lee, H., 2004, "Tangible Media based on Interactive Technology: iT_Media," *Proceedings of the 2004 International Conference on Control, Automation and Systems (ICCAS 2004)*.
- Yoon, J., Yoh, M. and Cho, B., 2004, "Emotional Robotics based on iTMedia," *Proceedings of the 2004 International Conference on Control, Automation and Systems (ICCAS 2004)*.
- Yoon, J., 2003, "Interactive Technology : Soft Engineering," *Proceedings of the 2003 International Conference on Control, Automation and Systems (ICCAS 2003)*.
- Yoon, J., Hwang, I. and Chang, S., 2000, "Metatechnology: Correspondence of the Arts, Sciences, Technology and Humans," *International Journal of the Korean Society Precision Engineering*, Vol. 1, No. 1, pp. 71~78.