

NON-COMPACT DOUGLAS-PLATEAU PROBLEM BOUNDED BY A LINE AND A JORDAN CURVE

SUN SOOK JIN

ABSTRACT. In this article, we prove the existence of a minimal annulus bounded by a Jordan curve and a straight line.

1. Introduction

In this paper we consider the Douglas-Plateau problem for surfaces of annular type bounded by a rectifiable Jordan curve and a straight line. Recall that the Douglas-Plateau problem for two contours as follows:

Let Γ_1 and Γ_2 be two disjoint Jordan curves in \mathbf{R}^3 ,
find a minimal annulus A such that $\partial A = \Gamma_1 \cup \Gamma_2$.

Let S_1 and S_2 be areas minimizing disks (when we say disks, we mean that they are homeomorphic to the unit disk in \mathbf{C}) such that $\partial S_i = \Gamma_i$, $i = 1, 2$, respectively. Let \mathcal{S} be the set of all rectifiable annuli S such that $\partial S = \Gamma_1 \cup \Gamma_2$. Then J. Douglas[4] proved that if

$$(1) \quad \inf_{S \in \mathcal{S}} \{\text{Area}(S)\} < \text{Area}(S_1) + \text{Area}(S_2),$$

then there is an area minimizing (therefore minimal) annulus bounded by $\Gamma_1 \cup \Gamma_2$. Now we consider the *non-compact* Douglas-Plateau problem of annular type containing at least one non-compact boundary curve. Recall there are many necessary conditions restricting the solvability of even *compact* Douglas-Plateau problems for two contours, therefore the solvability of the non-compact Douglas-Plateau problem seems should require more hypotheses than the compact case. It is known for more than one hundred years that for some non-compact boundaries we can

Received October 7, 2004.

2000 Mathematics Subject Classification: 53A10.

Key words and phrases: Douglas-Plateau problem, minimal surfaces, Riemann's minimal examples, Courant-Lebesgue lemma.

This research was supported by the Kyung Hee University Research Fund in 2004(KHU-20040457).

find minimal annuli solving the corresponding “two-contour” Douglas-Plateau problem. A classical example [10] is a minimal annulus bounded by two parallel straight lines, a piece of a *Riemann’s minimal example* which is foliated by circles and straight lines along horizontal planes. There are some recent results about the non-compact Douglas-Plateau problem, see [5], [6], [8], [9], etc,....

On the other hand, in 1990 F. Tomi and R. Ye[11] have shown that every rectifiable Jordan curve in \mathbf{R}^3 bounds a minimal immersion of the punctured disk which stretches out to infinity. The argument can be outlined as follows: Given a Jordan curve Γ , we choose a sequence of expanding round circles Γ_k and obtain a sequence of expanding the least area annuli which span Γ and Γ_k . Using an area estimate and Courant-Lebesgue type argument, we control the conformal types of these annuli and prove the convergence of their conformal parametrizations. Then we can take the limit surface of this sequence, which is the solution of the exterior Plateau problem for Γ . In this paper, we use this technique to construct a minimal annulus bounded by a rectifiable Jordan curve and a straight line as following:

THEOREM 1. *Let Γ be a rectifiable curve in \mathbf{R}^3 and L be a straight line, then there is a minimal annulus A^+ bounded by $\Gamma \cup L$.*

:

2. Preliminaries

Let $B := \{z \in \mathbf{C} : |z| < 1\}$ be the unit disk in the plane and let $X : B \rightarrow \mathbf{R}^3$ be an immersion which is given in conformal parameters $w = u + iv$, $u, v \in \mathbf{R}$, then the Dirichlet integral of X is defined by

$$D(X, B) := \frac{1}{2} \int \int_B (|X_u|^2 + |X_v|^2) dudv.$$

LEMMA 1 (Courant-Lebesgue lemma [2]). *Let $X \in C^0(\bar{B}, \mathbf{R}^3) \cap C^1(B, \mathbf{R}^3)$ and $D(X) < \infty$. Let $z_0 \in \partial B$ and*

$$Z(r, \theta) := X(z_0 + re^{i\theta}),$$

where r, θ denote polar coordinates about z_0 . Take a ball $B_R(z_0)$ with radius $0 < R < 1$ and centered at z_0 , and let

$$\bar{B} \cap \partial B_R(z_0) = \{z_0 + Re^{i\theta} : \theta_1(R) \leq \theta \leq \theta_2(R)\}.$$

Then for all $\delta \in (0, R^2)$, there is $\rho \in (\delta, \sqrt{\delta})$ such that for any angles θ_1, θ_2 with $\theta_1(\rho) \leq \theta_1 \leq \theta_2 \leq \theta_2(\rho)$, we have

$$(2) \quad \int_{\theta_1}^{\theta_2} \left| \frac{\partial Z}{\partial \theta}(\rho, \theta) \right| d\theta \leq \eta(\delta, R),$$

where

$$\eta(\delta, R) = \left\{ \frac{2}{\log 1/\delta} D(X, B \cap B_R(z_0)) \right\}^{1/2}$$

and in particular

$$(3) \quad |Z(\rho, \theta_1) - Z(\rho, \theta_2)| \leq \eta(\delta, R) |\theta_1 - \theta_2|^{1/2}.$$

LEMMA 2 (Reflection and Rotation Theorems [2]). *If a plane geodesic which is not a straight line segment lies on a minimal surface, then reflection in the plane of the geodesic is a congruence of the minimal surface. If a straight line segment lies on a minimal surface, then π -degree rotation around the straight line is a congruence of the minimal surface.*

3. Construction

Let us denote horizontal planes by

$$\begin{aligned} \Pi &:= \{(x_1, x_2, x_3) \in \mathbf{R}^3 : x_3 = 0\}, \\ \Pi^+ &:= \{(x_1, x_2, 0) : x_1 > 0\}. \end{aligned}$$

We assume that the given straight line L is the x_2 -axis line, and the rectifiable curve Γ meets Π^+ transversely. Take a planar half-disk D_R^+ contained in Π^+ with radius $R > 0$ as

$$D_R^+ := \{(x_1, x_2, 0) : x_1^2 + x_2^2 < R^2, x_1 > 0\}$$

and denote its boundary by $\Gamma_R^+ := \partial D_R^+$. We may assume that the projection of Γ onto the horizontal plane intersects to the half-disk. Then it is well known that Γ and Γ_R^+ bound the least area disks S_Γ and S_R^+ , respectively. Let us denote a solid cylinder

$$C_T := \{(x_1, x_2, x_3) \in \mathbf{R}^3 : x_1^2 + x_2^2 < T^2\}$$

with radius $T > 0$, and take $0 < T_0 < R$ such that $\Gamma \subset C_{T_0}$.

LEMMA 3 (Uniform Douglas conditions [11]). *For every $R > T_0$, we have*

$$(4) \quad a_{\Gamma, \Gamma_R^+} < \text{Area}(S_\Gamma) + \text{Area}(S_R^+) - \delta,$$

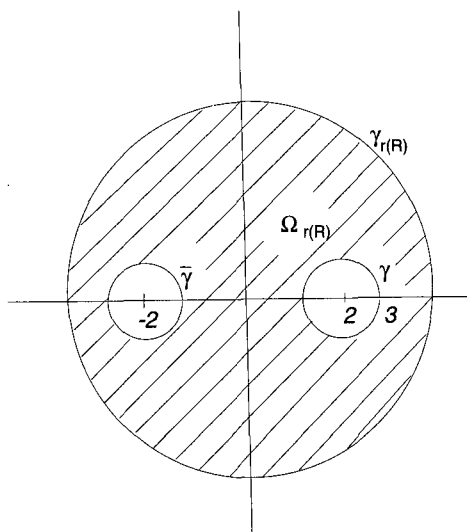

FIGURE 1.

where a_{Γ, Γ_R^+} is the infimum of area among all annulus type surfaces spanning Γ and Γ_R^+ , and $\delta > 0$ is independent constant of R .

Using this lemma and the Douglas sufficient condition (1), we have an area minimizing annulus $A_R^+ \subset \mathbf{R}^3$ such that

$$\partial A_R^+ = \Gamma \cup \Gamma_R^+.$$

Now by Lemma 2, we can rotate A_R^+ by the π -degree along the straight line L . Denote

$$\text{Rot}_L : \mathbf{R}^3 \rightarrow \mathbf{R}^3$$

by the π -degree rotation around the straight line L . Then we have a minimal surface A_R which is the union of A_R^+ and the rotated one, i.e.,

$$A_R := A_R^+ \cup \text{Rot}_L(A_R^+) \cup (L \cap C_R).$$

Conformally, A_R is equivalent to a 3-fold connected domain $\Omega_{r(R)} \subset \mathbf{C}$, which is also symmetric under a conformal mapping of the plane. So we can take the three boundary curves of it as following:

$$\begin{aligned} \partial \Omega_{r(R)} &:= \gamma \cup \bar{\gamma} \cup \gamma_{r(R)}, \\ \gamma &:= \{z \in \mathbf{C} : |z - 2| = 1\}, \quad \bar{\gamma} := \{-\bar{z} : z \in \gamma\}, \\ \gamma_{r(R)} &:= \{z \in \mathbf{C} : |z| < r(R)\}. \end{aligned}$$

Let us define a minimal immersion, i.e., a harmonic conformal mapping

$$X_R : \Omega_{r(R)} \rightarrow A_R \subset \mathbf{R}^3$$

such that $X_R|_\gamma = \Gamma$ and $X_R|_{\bar{\gamma}} = \bar{\Gamma} := \text{Rot}_L(\Gamma)$.

CLAIM 1. *If $R_k \rightarrow \infty$, then there is a subsequence of X_{R_k} which converges to a conformal harmonic map $X : \Omega \rightarrow \mathbf{R}^3$ locally smoothly in the interior of the unbounded domain Ω which is defined by*

$$\Omega := \mathbf{C} \setminus \overline{D_\gamma \cup D_{\bar{\gamma}}},$$

where D_γ and $D_{\bar{\gamma}}$ are the disks in the plane bounded by γ and $\bar{\gamma}$, respectively.

Throughout this article we assume that $T_0 < T$, where $\Gamma \subset C_{T_0}$. Let us denote the preimage of the subset of A_R contained in the solid cylinder with radius $T > 0$ by $\Lambda_{R,T}$, that is,

$$\Lambda_{R,T} := X_R^{-1}(A_R \cap C_T).$$

Denote the connected component of $\Lambda_{R,T}$ whose boundary contains $\gamma \cup \bar{\gamma}$ by $\Lambda_{R,T}^\gamma$. Recall, in a minimal surface, the Dirichlet integral is equal to the area of a surface. Since the orthogonal projection onto the x_1x_2 -plane does not increase area, we can get

$$(5) \quad D(X_R, \Lambda_{R,T}) \geq \pi T^2 - 2\pi d_\Gamma^2,$$

$$(6) \quad D(X_R, \Omega_{r(R)} \setminus \Lambda_{R,T}) \geq \pi R^2 - \pi T^2,$$

where d_Γ is the diameter of Γ . Recall Douglas condition (4) implies that

$$(7) \quad \begin{aligned} D(X_R, \Lambda_{R,T}) &= D(X_R, \Omega_{r(R)}) - D(X_R, \Omega_{r(R)} \setminus \Lambda_{R,T}) \\ &\leq \pi R^2 + 2a_\Gamma - (\pi R^2 - \pi T^2) \\ &= \pi T^2 + 2a_\Gamma \end{aligned}$$

if $a_\Gamma := \text{Area}(S_\Gamma)$ where S_Γ is the least area disk bounded by Γ . Thus for all $T_0 < T_1 < T_2$, together with (5) and (7), we have,

$$(8) \quad D(X_R, \Lambda_{R,T_2} \setminus \Lambda_{R,T_1}) \leq \pi T_2^2 - \pi T_1^2 + 2a_\Gamma + 2\pi d_\Gamma^2.$$

Now consider a point $z_0 \in \partial\Lambda_{R,T}^\gamma \setminus \gamma \cup \bar{\gamma}$ such that

$$\text{dist}_{\mathbf{C}}(z_0, \partial\Lambda_{R,2T}^\gamma \setminus \gamma \cup \bar{\gamma}) = r_0,$$

where r_0 is the distance between $\partial\Lambda_{R,2T}^\gamma \setminus \gamma \cup \bar{\gamma}$ and $\partial\Lambda_{R,T}^\gamma \setminus \gamma \cup \bar{\gamma}$. Denote

$$Z_R(r, \theta) := X_R(z_0 + re^{i\theta}),$$

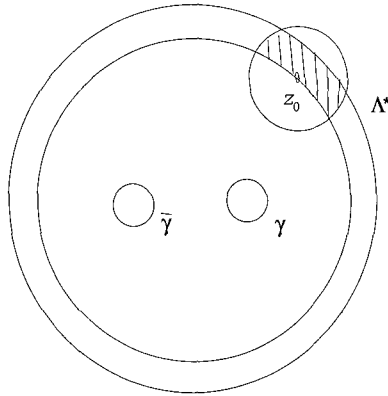

FIGURE 2.

where r, θ denote polar coordinates about z_0 . If $r_0 < 1$, then by (2) there exists $\rho \in (r_0, \sqrt{r_0})$ such that

$$(9) \quad \int_{\partial^*} \left| \frac{\partial Z}{\partial \theta}(\rho, \theta) \right| d\theta \leq \left\{ \frac{4\pi}{\log 1/r_0} D(X_R, \Lambda^*) \right\}^{1/2},$$

where

$$\begin{aligned} \Lambda^* &:= B_{\sqrt{r_0}}(z_0) \cap (\Lambda_{R,2T}^\gamma \setminus \Lambda_{R,T}), \\ \partial^* &:= \partial B_\rho(z_0) \cap (\Lambda_{R,2T}^\gamma \setminus \Lambda_{R,T}). \end{aligned}$$

Notice, since $r_0 < \rho$ we can find an arc $\zeta \subset \partial^*$ connecting $\partial \Lambda_{R,2T}^\gamma \setminus \gamma \cup \bar{\gamma}$ and $\partial \Lambda_{R,T} \setminus \gamma \cup \bar{\gamma}$. So the length of $X_R(\zeta)$ must be larger than T . Since the length of $X_R(\zeta)$ is less than that of $X_R(\partial^*)$, together with (8) and (9), we have

$$T^2 < \frac{4\pi}{\log 1/r_0} (4\pi T^2 - \pi T^2 + 2a_\Gamma + 2\pi d_\Gamma^2)$$

as well as

$$\begin{aligned} r_0 &\geq \exp(-4\pi T^{-2}(3\pi T^2 + 2a_\Gamma + 2\pi d_\Gamma^2)) \\ &= \exp(-12\pi^2 - 4\pi(2a_\Gamma + 2\pi d_\Gamma^2)T^{-2}) \\ &\geq \exp(-8\pi a_\Gamma - 20\pi^2). \end{aligned}$$

Observe this inequality also holds if $r_0 \geq 1$. Take a number $N > 0$ such that

$$2^{-N}T = T_0 + 1 + \epsilon, \quad 0 < \epsilon < 1,$$

then

$$\begin{aligned}
 & \text{dist}_{\mathbf{C}}(0, \partial\Lambda_{R,T} \setminus \gamma \cup \bar{\gamma}) \\
 (10) \quad &= \sum_{k=1}^N \text{dist}_{\mathbf{C}}\left(\partial\Lambda_{R,2^{-k}T}^\gamma \setminus \gamma \cup \bar{\gamma}, \partial\Lambda_{R,2^{1-k}T}^\gamma \setminus \gamma \cup \bar{\gamma}\right) \\
 &\geq N \exp(-8\pi a_\Gamma - 20\pi^2) \\
 &\geq c \log T
 \end{aligned}$$

for some constant $c > 0$ satisfying

$$N = \log_2 T - \log_2(T_0 + 1 + \epsilon) \geq c \exp(8\pi a_\Gamma + 20\pi^2) \log T.$$

Notice that we can take c independently with the value T . In particular,

$$r(R) = \text{dist}_{\mathbf{C}}(0, \partial\Lambda_{R,R} \setminus \gamma \cup \bar{\gamma}) \geq c \log R.$$

Take $3 < r \leq r(R)$, and let T satisfy that

$$\text{dist}_{\mathbf{C}}(0, \partial\Lambda_{R,T} \setminus \gamma \cup \bar{\gamma}) = r.$$

Then $X_R(\Omega_r) \subset C_T$ clearly, so

$$\begin{aligned}
 (11) \quad D(X_R, \Omega_r) &\leq D(X_R, \Lambda_{R,T}) \\
 &\leq \pi T^2 + 2a_\Gamma \\
 &\leq \pi e^{2r/c} + 2a_\Gamma
 \end{aligned}$$

by (10). It leads us to prove that there is a subsequence of X_{R_k} and a conformal harmonic map $X \in C^0(\Omega, \mathbf{R}^3) \cap C^\omega(\text{Int}(\Omega), \mathbf{R}^3)$ with

$$\Omega := \mathbf{C} \setminus \overline{D_\gamma \cup D_{\bar{\gamma}}}$$

such that

- X_{R_k} converges to X uniformly on every Ω_r .
- X_{R_k} converges to X weakly in each $H_2^1(\Omega_a, \mathbf{R}^3)$.
- X_{R_k} converges to X locally smoothly in $\text{Int}(\Omega)$.

CLAIM 2. *The sequence of minimal immersions X_{R_k} is equicontinuous on the boundary curves $\partial\Omega = \gamma \cup \bar{\gamma}$.*

Let $M := \pi e^{10/c} + 2a_\Gamma$ as in (11), then for all $r_k < 5$ we have

$$(12) \quad D(X_{R_k}, B_{r_k} \cap \Omega_r) \leq M.$$

Recall the set of surfaces X_{R_k} satisfy the *three-point condition* for γ if

$$(13) \quad X_{R_k}(w_j) = Q_j, \quad j = 1, 2, 3,$$

for some $w_1, w_2, w_3 \in \gamma$ and $Q_1, Q_2, Q_3 \in \Gamma$. The condition (3) of the Courant-Lebesgue lemma can be applied as follows: Since Γ is the topological image of a unit circle $C := \{z \in \mathbf{C} : |z| = 1\}$ for every $\epsilon_k > 0$ there exists a number $\lambda(\epsilon_k) > 0$ with the following property: Any pair of points $P, Q \in \Gamma$ with

$$0 < |P - Q| < \lambda(\epsilon_k)$$

decompose Γ into two arcs $\Gamma_1(P, Q)$ and $\Gamma_2(P, Q)$ such that

$$\text{length}(\Gamma_1(P, Q)) < \epsilon_k$$

holds. Hence, if $0 < \epsilon_k < e := \min_{j \neq k} |Q_j - Q_k|$, $j, k = 1, 2, 3$, then $\Gamma_1(P, Q)$ can contain at most one of the points Q_1, Q_2, Q_3 appearing in (13). Let $d \in (0, 1)$ be a fixed number with

$$2\sqrt{d} < \min_{j \neq k} |w_j - w_k|,$$

where w_1, w_2, w_3 appear in (13). For an arbitrary $\epsilon_k \in (0, e)$, we choose some number $\delta_k = \delta_k(\epsilon_k)$ such that

$$\left\{ \frac{4\pi M}{\log 1/\delta_k} \right\}^{1/2} < \lambda(\epsilon_k)$$

and $\delta_k < d$. Consider an arbitrary point z_1 on γ , and let $\rho \in (\delta_k, \sqrt{\delta_k})$ be some number such that the images $P := X_{R_k}(z)$, $Q := X_{R_k}(z')$ of the two intersection points $z, z' \in \gamma$ and $\partial B_\rho(z_1)$ satisfy

$$|P - Q| \leq \left\{ \frac{4\pi M}{\log 1/\delta_k} \right\}^{1/2}.$$

Then we infer that $|P - Q| < \lambda(\epsilon_k)$, whence $\text{length}(\Gamma_1(P, Q)) < \epsilon_k$ holds. Because of $\epsilon_k < e$ the arc $\Gamma_1(P, Q)$ contains at most one of the points Q_1, Q_2, Q_3 . On the other hand, if the sequence X_{R_k} satisfy the three-point condition then $X_{R_k}(\overline{\gamma \cap B_\rho(z_1)})$ contains at most one of the points Q_j and must therefore coincide with the arc $\Gamma_1(P, Q)$.

On the contrary, we assume that X_{R_k} are not equicontinuous on γ . Then, together with the condition (12), we can say that they do not satisfy the three-point condition, see Lemma 3.2 in [1]. Observe then we can take a point $w_0 \in \gamma$ and $r_k \in (\delta_k, \sqrt{\delta_k})$ such that

$$\Gamma_1(P, Q) \neq X_{R_k}(\overline{\gamma \cap B_{r_k}(w_0)})$$

in other words, the complementary arc

$$\Gamma_k^* := \Gamma \setminus X_{R_k}(\overline{\gamma \cap B_{r_k}(z)})$$

has the smaller length ϵ_k . Let $\epsilon_k \rightarrow 0$ as $k \rightarrow \infty$, then it follows that

$$\lim_{k \rightarrow \infty} \text{length}(\Gamma_k^*) = 0.$$

And let $\delta_k \rightarrow 0$ as $k \rightarrow \infty$, too. Then, via the Courant-Lebesgue lemma again, we have

$$\begin{aligned} \text{length}(X_{R_k}(\partial B_{r_k}(z) \cap \Omega_r)) &= \int_{\partial B_{r_k}(z) \cap \Omega_r} \left| \frac{\partial X_{R_k}}{\partial \theta} \right| d\theta \\ &\leq \left\{ \frac{4\pi M}{\log 1/\sqrt{\delta_k}} \right\}^{1/2} \\ &\rightarrow 0 \quad \text{as } k \rightarrow \infty. \end{aligned}$$

Notice that together with the arc $\partial B_{r_k}(z) \cap \Omega$ and a simple regular arc $\xi_{r_k} \subset \text{Int}(\Omega) \setminus B_{r_k}(z)$ which lies within short distance to γ such that

$$\lim_{k \rightarrow \infty} \text{length}(X_{R_k}(\xi_{r_k})) = \lim_{k \rightarrow \infty} \text{length}(\Gamma_k^*) = 0$$

and rounding off corners, one easily constructs a closed regular Jordan curve $\eta_k \subset \text{Int}(\Omega_{r(R_k)})$ satisfying

1. The length of image's $X_{R_k}(\eta_k)$ tends to zero as $k \rightarrow \infty$.
2. η_k cuts the domain $\Omega_{r(R_k)}$ into two annular regions.

Now we can apply the cut-paste argument to obtain disk type surfaces A_k^1 and A_k^2 such that the first surface bounds Γ and the last one bounds $\Gamma_{R_k}^+$ such that

$$\lim_{k \rightarrow \infty} (\text{Area}(A_k^1) + \text{Area}(A_k^2) - \text{Area}(A_{R_k}^+)) = 0$$

contradicts to Lemma 1, however. It leads us that the sequence X_{R_k} must be equicontinuous on γ , and so on $\bar{\gamma}$ for the symmetricity. Therefore, the limit curve $X(\gamma)$ is a topological parametrization of Γ . Let us denote

$$A := X(\Omega).$$

Since $(A_{R_k} \cap \Pi) \setminus (\Gamma \cup \bar{\Gamma})$ tends to the straight line L as $k \rightarrow \infty$, the limit surface A also contains L in its interior and then rotational symmetric under the line. Therefore we can take a minimal annulus $A^+ \subset A$ bounded by Γ and L , it finished the proof of the main theorem of this article.

References

- [1] R. Courant, *Dirichlet's principle, conformal mapping and minimal surfaces*, New York, Interscience, 1950.
- [2] U. Dierkes, S. Hildebrandt, A. Küster, and O. Wohlrab, *Minimal Surfaces 1*, Springer-Verlag, 1992.
- [3] J. Douglas, *Solution to the problem of Plateau*, Trans. Amer. Math. Soc. **33** (1931), 263–321.
- [4] ———, *The problem of Plateau for two contours*, J. Math. Phys. Massachusetts Inst. of Tech. **10** (1930/31), 315–359.
- [5] Yi Fang, *On minimal annuli in a slab*, Comm. Math. Helv. **69** (1994), 417–430.
- [6] Yi Fang and Jenn-Fang Hwang, *Curvature estimates for minimal annuli and non-compact Douglas-Plateau problem*, Comm. Anal. Geom. **8** (2000), no. 4, 871–904.
- [7] H. Jenkins and J. Serrin, *Variational problems of minimal surface type, 2, Boundary value problems for the minimal surface equation*, Arch. Rational Mech. Anal. **21** (1966), 321–342.
- [8] F. J. López and F. Wei, *Properly immersed minimal discs bounded by straight lines*, Math. Ann. **318** (2000), 667–706.
- [9] J. Perez and A. Ros, *Properly embedded minimal annuli bounded by a convex curve*, Journal de l'Institut Mathématique de Jussieu **1** (2002), no. 2, 293–305.
- [10] B. Riemann, *Über die Fläche vom kleinsten Inhalt bei gegebener Begrenzung*, Abh. Königl. d. Wiss. Göttingen, Mathem. Cl. **13** (1867), 3–52.
- [11] F. Tomi and R. Ye, *The exterior plateau problem*, Math. Z. **205** (1990), 233–245.

Major in Mathematics and Applies Mathematics
College of Electronics and Information
Kyung Hee University
Yongin 449-701, Korea
E-mail: ssjin@khu.ac.kr