

A Small Monopole Antenna with Novel Impedance Matching Structure

새로운 임피던스 매칭 구조를 가지는 소형 모노폴 안테나

Dong-Jin Kim · Kyeong-Sik Min

김 동 진 · 민 경 식

Abstract

A small monopole antenna with a novel impedance matching structure is proposed in this paper. The proposed antenna is designed for W-LAN(IEEE 802.11b). The antenna design concept is based on a $\lambda/8$ folded monopole antenna with a self-impedance matching structure. The size of the proposed antenna is smaller than the resonant length, thus the impedance at the terminal of the antenna becomes very capacitive. To compensate for this impedance mismatching, the proposed antenna employs a novel self-impedance matching structure. The self-impedance matching structure is located on the top of the antenna; it improves the impedance matching and ultimately the efficiency of the antenna. The measured results of the proposed antenna show reasonable agreement with prediction.

요 약

본 논문에서는 임피던스 매칭 구조를 가진 소형 모노폴 안테나를 제안하고 그 특성들을 나타내었다. 안테나 매칭을 위해서 안테나 상단에 구성된 inductive 매칭 구조는 효과적으로 안테나의 capacitive 성분들을 보상하여 설계 대역에서 임피던스 매칭이 잘 이루어지는 효과를 보였다. 기존의 많은 소형 안테나들이 임피던스 매칭을 위하여 별도의 매칭 구조를 안테나의 입력부에 적용한 것과는 달리 본 논문에서 제안한 방법은 안테나의 상단에 매칭 구조를 위치시킴으로써 비교적 적은 공간을 이용하여 효과적으로 안테나의 입력 임피던스를 매칭할 수 있는 방법을 제시하였다. 제안한 안테나는 중심 주파수에 대하여 40 % 이상의 대역폭과 95 % 이상의 방사 효율을 보이며, 2.6~3 dBi 정도의 높은 이득 특성을 보이므로 향후 단말기 혹은 여러 분야에 적용될 수 있을 것으로 기대된다.

Key words : Self-Impedance Matching Antenna, Capacitive Monopole Element, Inductive Matching Line, Broad Bandwidth Antenna, Wheeler-Cap Method

I. Introduction

The demand for smaller communication devices for personal communication systems has led to a considerable amount of research into methods of reducing the personal devices used for radio communications. Because of the recent trend toward their miniaturization, it is necessary to develop circuits, chips and antennas for mobile devices. Especially, miniaturization is very much required for antenna devices, since they occupy a

large space in mobile handy terminals. However, the wavelength does not decrease with the same speed as the size of the mobile phones due to the higher frequency bands used^[1]. Even a quarter wavelength antenna, such as the planar monopole antenna, tends to become too large, thus creating a demand to decrease the size of the antenna.

Size reduction can be accomplished simply by shortening the antenna or using high permittivity dielectric substrates, etc.^{[2],[3]}. However, at lengths shorter than the

한국해양대학교 전파공학과 (Department of Radio Sciences and Engineering, Korea Maritime University)

· 논문 번호 : 20061220-05S

· 수정완료일자 : 2007년 7월 2일

resonant length, the radiation resistance changes, and the impedance at the terminals of the antenna become reactive. The latter can be compensated for by the self-impedance matching structure which is proposed in this research. The self-impedance matching structure is employed for the cancellation of the capacitance, thus it improves the impedance matching and the efficiency of the antenna^[1]. In this research, we designed an antenna for the W-LAN band. Therefore, we assumed that the proposed antenna operates according to IEEE 802.11b (2.4~2.484 GHz) and it satisfies the IEEE 802.11b frequency band with a VSWR of less than 2. We expect the antenna to show omni-directional radiation patterns in all frequency bands.

In recent years, almost mobile devices designed for W-LAN employ $\lambda/4$ antennas^[4]. However it is necessary to considerably reduce the antenna size due to the recent trend toward mobile devices with a smaller size. Thus, we propose a planar monopole antenna with a length of $\lambda/8$ in this research. Not only did we attempt to reduce the size of the antenna, but we also investigated the possibility of reducing the size of the ground plane for practical usage. We assumed that the proposed monopole antenna has a ground plane with a width smaller than $\lambda/4$ for its adoption in mobile devices. In this research, an FR4 ($\epsilon_r=4.4$, thickness=1 mm) dielectric substrate is used for the antenna design

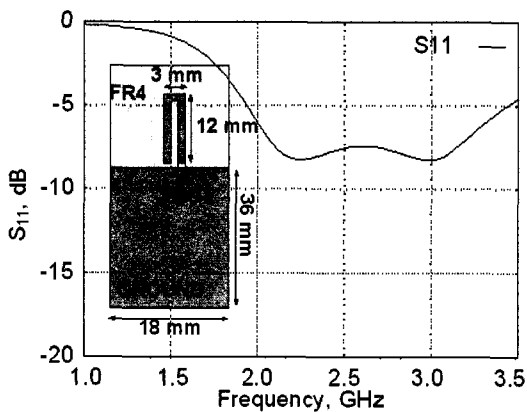

Fig. 1. A typical $\lambda/8$ wavelength folded monopole antenna and its return loss.

due to its low price and reasonable permittivity constant.

II. Antenna Design Process

Fig. 1 shows the folded monopole antenna with a length of $\lambda/8$. The total length of the folded monopole antenna is about $\lambda/4$, and it shows the resonant phenomenon at around 2~3 GHz. However, as shown in Fig. 2, the impedance of the antenna shows highly capacitive characteristics at the design frequency. Thus, we need to compensate for these capacitive characteristics by using some impedance matching methods. Therefore, we introduce a novel method of achieving effective impedance matching at the terminal of the antenna. As is well known, in general, the input impedance of small antennas smaller than $\lambda/4$ is very capacitive, so we must find an effective matching method for the compensation of the capacitive reactance on the antenna structure.

The antenna used in this research shows highly capacitive characteristics(Figs. 1 and 2), thus an inductive matching method is employed, as shown in the equivalent circuit in Fig. 3(b). Fig. 4 shows the antenna structure with the inductive line for impedance matching and its impedance characteristic. Through the effect of the inductive line on the top of the antenna, the capa-

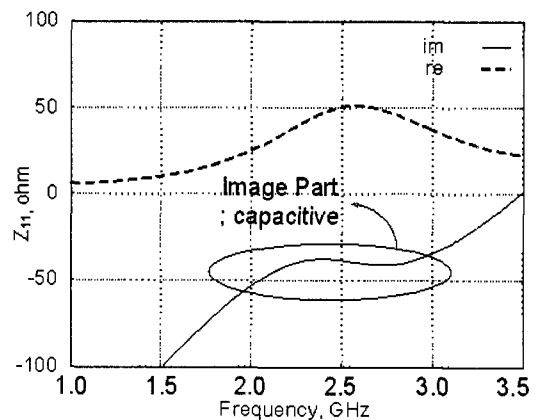
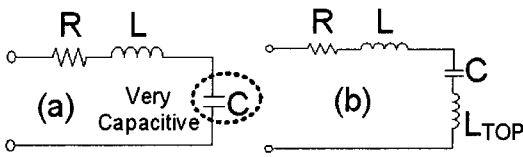

Fig. 2. The impedance characteristic of the typical $\lambda/8$ wavelength folded monopole antenna.



(a) A general equivalent circuit for small antennas
(b) The equivalent circuit of the small antenna proposed in this paper.

Fig. 3. Equivalent circuits of the small antennas.

citive imaginary part of the antenna impedance is considerably reduced. However, the antenna still shows capacitive characteristics, so it is necessary to reduce the capacitive imaginary part of the antenna impedance. For better impedance matching, as an application of the structure shown in Fig. 4, the symmetrical inductive meander line on the top of the folded monopole structure in Fig. 5 is considered. Fig. 5 shows the proposed symmetrical antenna structure designed to improve the impedance matching. Figs. 6 and 7 show the return loss and impedance characteristic of the proposed antenna structure, respectively. Table 1 shows the optimized parameters of the proposed antenna.

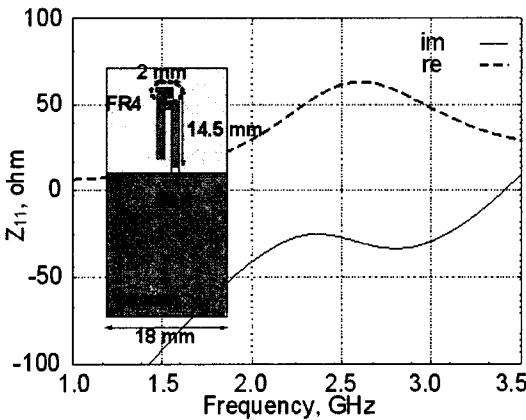
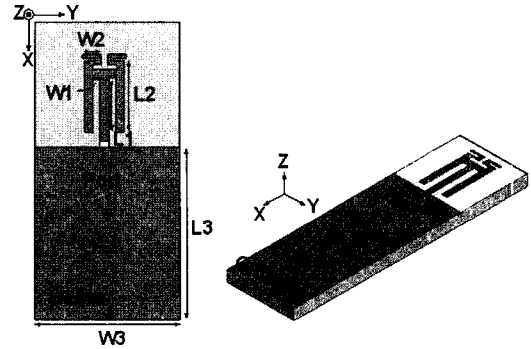

Fig. 4. The $\lambda/8$ wavelength folded monopole antenna with inductive matching line and its impedance characteristic.

Table 1. Parameters for the proposed antenna structure(Fig. 5)(unit: mm).

L_1	L_2	L_3	W_1	W_2	W_3
11.5	12	36	1	2	18



(a) Top view (b) 3D view

Fig. 5. The configuration of the proposed $\lambda/8$ symmetrical folded monopole antenna with inductive matching lines.

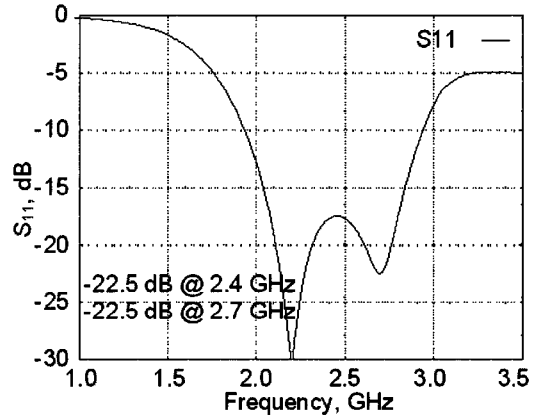

Fig. 6. The return loss of the proposed $\lambda/8$ symmetrical folded monopole antenna with inductive matching lines.

As shown in Fig. 6, the antenna return loss shows dual resonances at 2.4 GHz and 3 GHz, respectively. These two resonance frequencies are close to each other, so the antenna return loss shows broad bandwidth characteristics from 2 GHz to 3.25 GHz at a VSWR of less than 2. The bandwidth of the antenna is more than 47 % about the center frequency under the design conditions(2.4~2.484 GHz). The broad bandwidth characteristic of the proposed antenna is based on the antenna structure, and is explained in Fig. 8.

In Fig. 8, the reason for the dual resonance can be clearly seen. According to the current paths at each frequency, the inductive lines on the top of the antenna

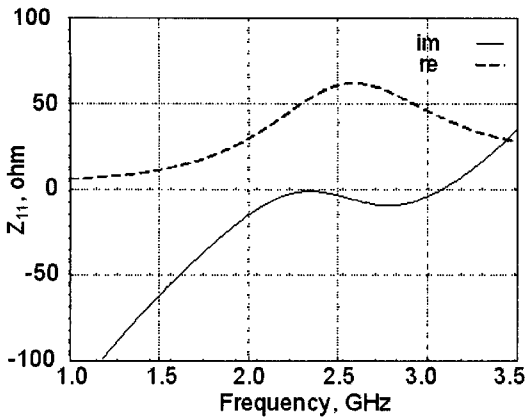

Fig. 7. The impedance characteristic of the proposed $\lambda/8$ symmetrical folded monopole antenna with inductive matching lines.

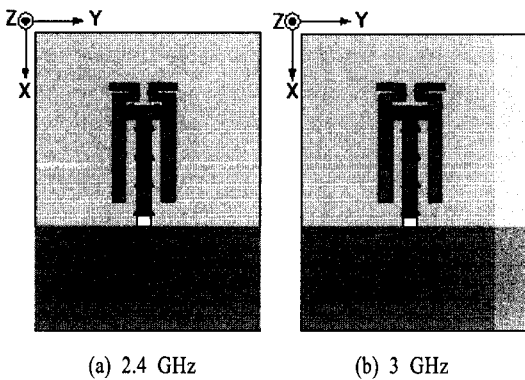

Fig. 8. Current paths for each resonance frequency of the proposed $\lambda/8$ symmetrical folded monopole antenna with inductive matching lines.

operate as the impedance matching structure for both low and high resonance frequencies and, as shown in Fig. 8, the antenna structure is constructed for dual resonance. Thus, the impedance matching structure successfully matches the antenna impedance for both low and high resonance frequencies; therefore the performance of the proposed antenna is very good for broad bandwidth operation.

Fig. 9 shows the radiation patterns of the proposed antenna at each resonance frequency. The E-plane and H-plane of the antenna radiation patterns are similar to the typical monopole antenna radiation patterns, even though the antenna structure is remarkably smaller than

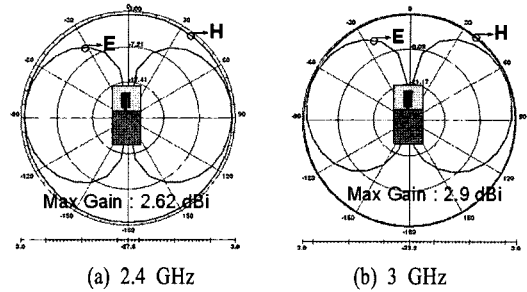

Fig. 9. Radiation patterns of the proposed $\lambda/8$ symmetrical folded monopole antenna with inductive matching lines at the resonance frequencies.

that of a typical monopole antenna. The calculated antenna gains at 2.4 GHz and 2.7 GHz are 2.62 dBi and 2.9 dBi, respectively, which is reasonable results compared with the typical $\lambda/4$ monopole antenna gain. These reasonable radiation patterns and antenna gains are realized by the good impedance matching with the inductive lines on the top of the antenna.

III. Experimental Results

In this paper, a $\lambda/8$ wavelength folded monopole antenna with a self-impedance matching structure is presented. We suggested a novel method of developing an antenna impedance matching structure using the inductive lines on the top of the antenna; it allows for the effective compensation of the capacitive characteristics of the antenna.

Figs. 10 and 11 show the measured return loss and antenna radiation patterns of the fabricated antenna. Although the measured return loss is slightly different from the simulated one, the measurement and fabrication errors, these two values show reasonable agreement. The measured radiation patterns of the fabricated antenna correspond to those of a typical dipole antenna and the measured antenna gain is $-0.3 \sim 1$ dBi in the resonance frequency bands. The antenna radiation efficiency was examined by using the Wheeler-Cap method^[6], and was about 95~99 % in the 2~3 GHz bands(Fig. 12).

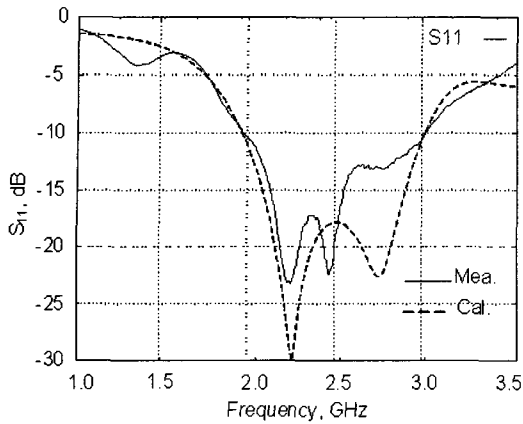

Fig. 10. Measured return loss of the fabricated antenna proposed in this research.

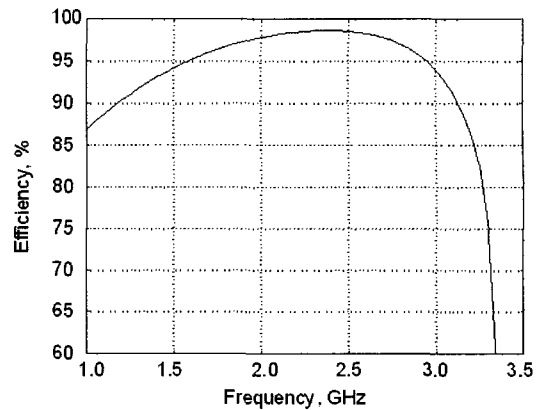

Fig. 12. Measured antenna radiation efficiency of the fabricated antenna proposed in this research obtained using the Wheeler-Cap method.

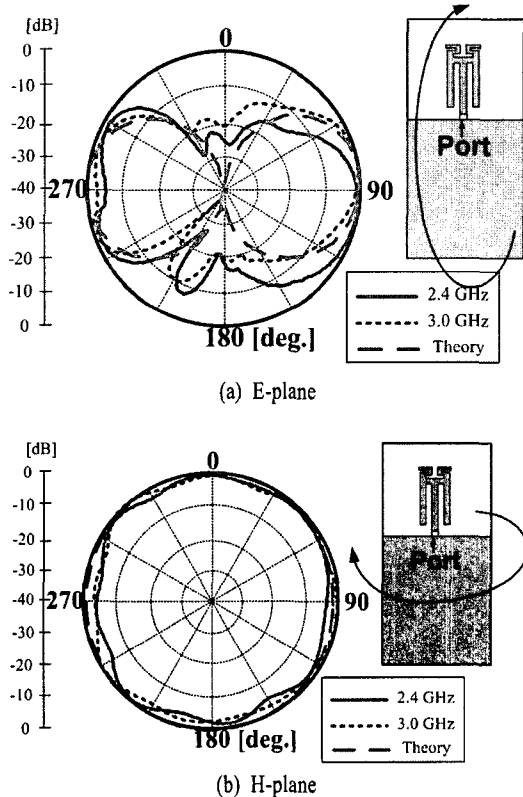

Fig. 11. Measured antenna radiation patterns of the fabricated antenna proposed in this research.

IV. Conclusion

The proposed antenna shows good performance for the W-LAN band and it can operate well above the

W-LAN band, due to its dual resonance characteristic afforded by the antenna structure. The radiation patterns and gain of the antenna show reasonable results, in spite of its remarkably small structure. Although the proposed antenna has a size of $\lambda/8$, it shows omni-directional radiation patterns and high gain of about 2.6~3 dBi in the 2~3 GHz frequency band. This antenna with novel structure shows the broadband width of above 40 % and the antenna radiation efficiency of above 95 %. Due to its small size and good performance, we expect that the proposed antenna will be applied to mobile handy terminals such as PDA and laptop computers.

References

- [1] Jesper Thaysen, Kay B. Jakobsen, "A size reduction technique for mobile phone PIFA antennas using lumped inductors", *Microwave Journal*, Jul. 2005.
- [2] Hiroyuki Arai, "Small antennas: Downsizing techniques and its index factor", *IEICE Transaction on Communications*, vol. E88. no. 5, pp. 1801-1808, May 2005.
- [3] T. K. Lo, C. Ho, Y. Hwang, E. Lam, and B. Lee, "Miniature aperture-coupled microstrip antenna of very high permittivity", *Electron. Letter*, vol. 33, no. 1, pp. 9-10, 1997.
- [4] G. S. Chae, Youngmin Moon, and J. S. Lim, "Small

printed antennas with folded shorted-strip for dual-band WLAN", *ISAP Proceeding*, vol. 1, pp. 133-136, Aug. 2005.

[5] Constantine A. Balanis, *Antenna Theory: Analysis and Design*, John Wiley & Sons, Inc., 1982.

[6] Darioush Agahi, William Domino, "Efficiency measurements of portable-handset antennas using the wheeler cap", *Applied Microwave and Wireless*, vol. 12, no. 6, pp. 34-42, Jun. 2000.

김 동 진



안테나

2005년 2월: 한국해양대학교 전파 공학과 (공학사)

2007년 2월: 한국해양대학교 전파 공학과 (공학석사)

2007년 3월~현재: 삼성종합기술원 연구원

[주 관심분야] MIMO 안테나, 소형

민 경 식



1989년 2월: 한국해양대학교 전자통신공학과 (공학사)

1991년 2월: 한국해양대학교 전자통신공학과 (공학석사)

1996년 2월: 일본동경공업대학교 전기전자공학과 (공학박사)

1997년 3월~현재: 한국해양대학교

전파공학과 부교수

[주 관심분야] RFID, MIMO 안테나, 슬롯 어레이 도파관 안테나, 초고주파 회로 및 안테나 설계용 프로그램 개발 등