

JPE 8-2-4

Fuzzy Pre-Compensated PI Control of Active Filters

Bhim Singh[†] and Varun Singhal^{*}

^{†*}Department of Electrical Engineering, I.I.T. Delhi, New Delhi, India

ABSTRACT

This paper deals with a new and improved control technique for shunt active filters (AF) used for compensating unwanted harmonic currents injected in the mains due to nonlinear varying loads. This work is motivated by the need to find a permanent solution to the rigorous hit and trial method for evaluating system parameters in an indirect control of AF. A fuzzy pre-compensated PI (Proportional-Integral) controller is used to fuzzify the reference DC voltage of AF to the controller input so that the overshoots and undershoots in its DC link voltage are minimized and the settling time is improved. A three-phase diode rectifier with R-L (Resistive-Inductive) load is used as a non-linear load to study the effectiveness of the proposed controller of the AF. Robustness to filter parameter variations, insensitivity to controller parameter variations, and transient response has been taken as performance evaluation parameters. The results are shown through simulations in Matlab using power system block sets to demonstrate the capability of the proposed controller of the AF.

Keywords: Active filters, Harmonic Compensation, Power Factor Correction, Fuzzy Pre-compensation

1. Introduction

Solid-state control of the AC power using power converters is in extensive use in a number of applications such as adjustable speed drives, furnaces, and computer power supplies. These power converters behave as non-linear loads to the AC supply system and cause harmonic injection and low power-factor problems. Moreover, these loads suffer continuous perturbations depending upon the time of operation and peak load time. These perturbations cause a dip or a swell in the load current requirements that directly affect the systems.

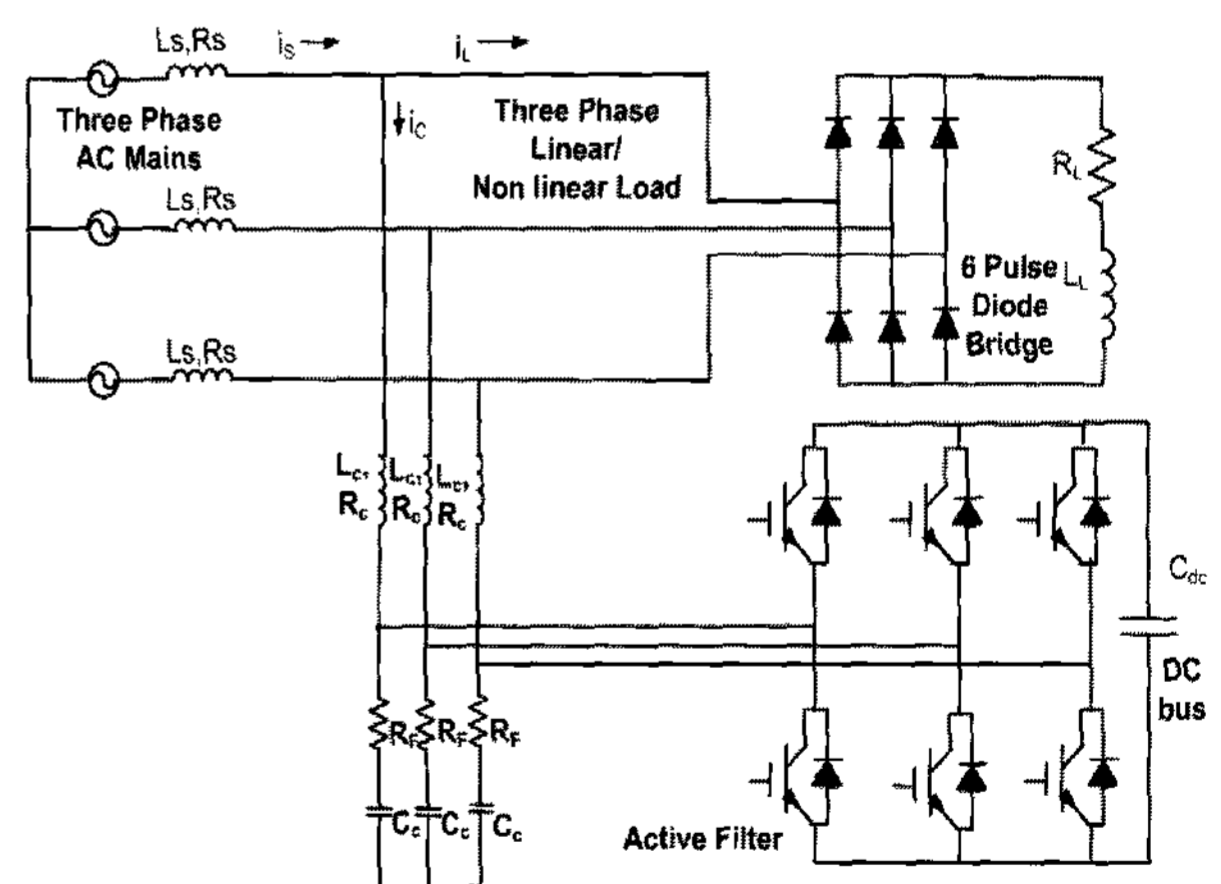

Fig. 1 Fundamental building block of active filter

Manuscript received Dec. 10, 2007; revised Jan. 23, 2008

[†] Corresponding Author: bsingh@ee.iitd.ac.in

Tel: +91-11-2659-1045, I. I.T. Delhi New Delhi, India

^{*}Dept. of Electrical Eng., I. I.T. Delhi, New Delhi, India

Active filters have appeared to be a promising solution [1-8] to compensate these effects.

Several control schemes for active filters can be found

in the literature, including instantaneous reactive power theory [1], direct control [2], sliding mode control [3], and genetic algorithm [4-5], to name a few. However, as reported in [6], most of these control algorithms need a number of transformations and are difficult to implement. The improved control algorithm proposed in [6] takes care of all the problems encountered in previous algorithms. However, this algorithm faces the problem of rigorous hit and trial analysis to evaluate the controller parameters of the system. Once the DC bus is stable and the load is

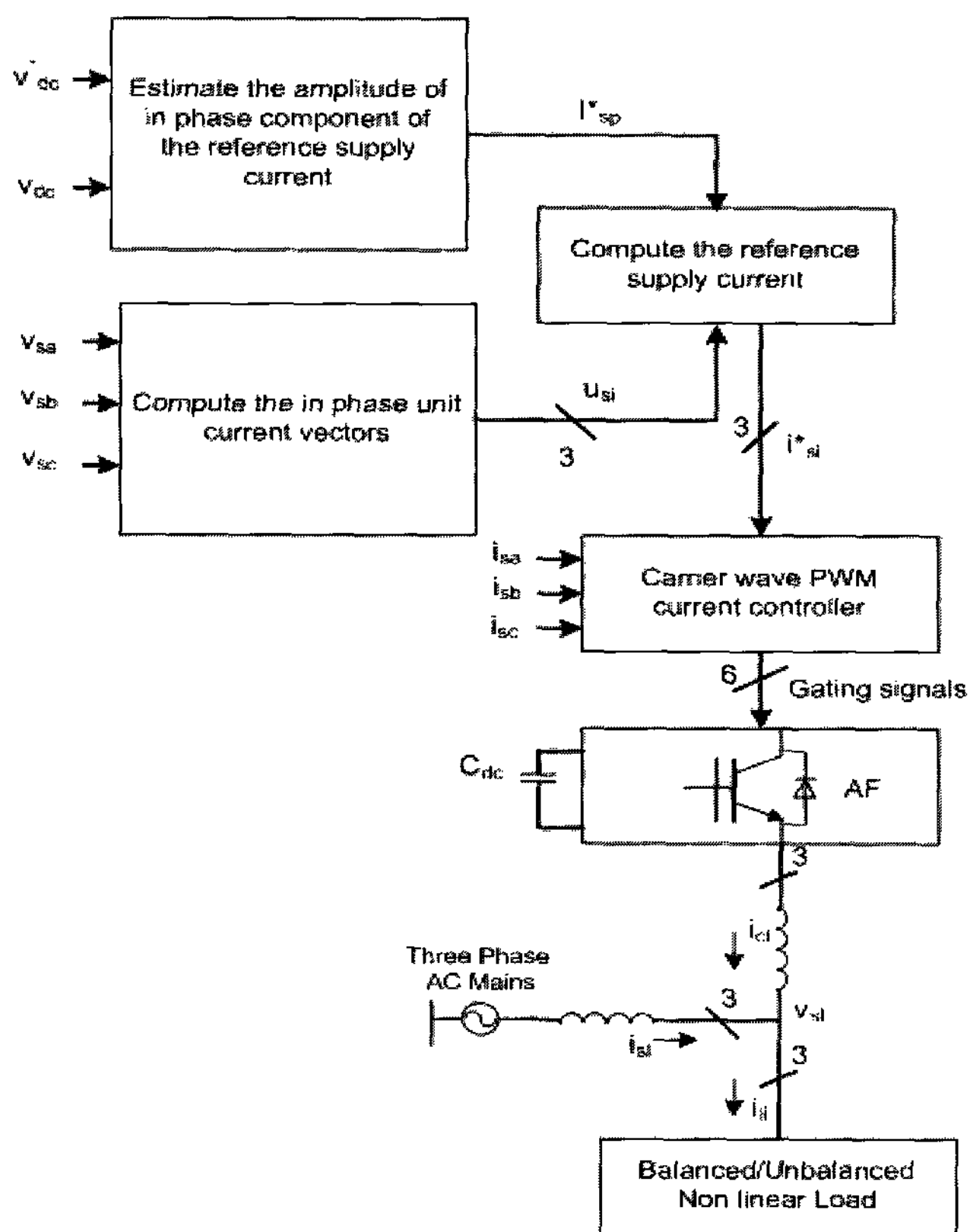

Fig. 2 Control Scheme for Indirect Control of active filter

perturbed, depending on the kind of load perturbation, a swell or dip in the DC link voltage is observed. These directly affects the settling time, the peak overshoot and undershoot of the DC link voltage.

A fuzzy pre-compensated controller [7-8] is emerging as an effective control method to fuzzify the reference to any PI (Proportional -Integral) controller in order to reduce the overshoots and undershoots. A fuzzy pre-compensated PI controller hence is incepted to give optimal performance for active filters. The complete design of the proposed

fuzzy pre-compensated PI controller for active filters is given and the results are shown to corroborate its effectiveness.

2. Indirect Current Control

Fig. 2 shows the control scheme of the active filter. The band pass filtered voltages (v_{sa} , v_{sb} , v_{sc}) from point of common coupling are used to evaluate unit current vectors in phase with supply voltages as (1).

$$u_{sa} = v_{sa}/V_{sp}; u_{sb} = v_{sb}/V_{sp} \text{ and } u_{sc} = v_{sc}/V_{sp} \quad (1)$$

where, V_{sp} is the amplitude of supply voltage computed as:

$$V_{sp} = \left\{ (2/3)(v_{sa}^2 + v_{sb}^2 + v_{sc}^2) \right\}^{1/2} \quad (2)$$

The self-supporting DC bus of the AF is realized using a PI controller over the sensed (v_{dc}) and reference (v_{dc}^*) values of the DC bus voltage of the AF. The PI voltage controller on the DC bus voltage of the AF provides the amplitude (i_{sp}^*) of the in-phase components of reference supply currents obtained by multiplying the amplitude with unit current vectors (1).

This reference source current is compared with the sensed source current and is fed to a 15 kHz PWM current controller to generate the gating signals of the six IGBT's (Insulated Gate Bipolar Transistors) used in the VSI (Voltage Source Inverter) bridge working as an AF. The input to the PI controller is fuzzified in order to decrease the peak overshoots and undershoots. The design and principle of the fuzzy pre-compensated PI controller for the active filter is discussed in detail now.

3. Fuzzy Pre-Compensated PI Controller for Active Filter

Fig. 3 shows the basic control structure of a fuzzy pre-compensated PI controller [7]. The input to the PI controller is the error e' given by $(v_{dc}' - v_{dc_filter})$ where, v_{dc}' is the fuzzy output and v_{dc_filter} is the DC link voltage passed through a low pass filter tuned at 11 Hz (to filter the high frequency perturbations). v_{dc}' is essentially

the sum of v_{dc}^* , the reference DC voltage and γ , the actual fuzzified output from the fuzzy block. The governing equations of the controller are given as (3)-(6). The map F is the actual fuzzy implementation on $e(k)$ and $\Delta e(k)$.

$$e(k) = v_{dc}^*(k) - v_{dc}(k) \quad (3)$$

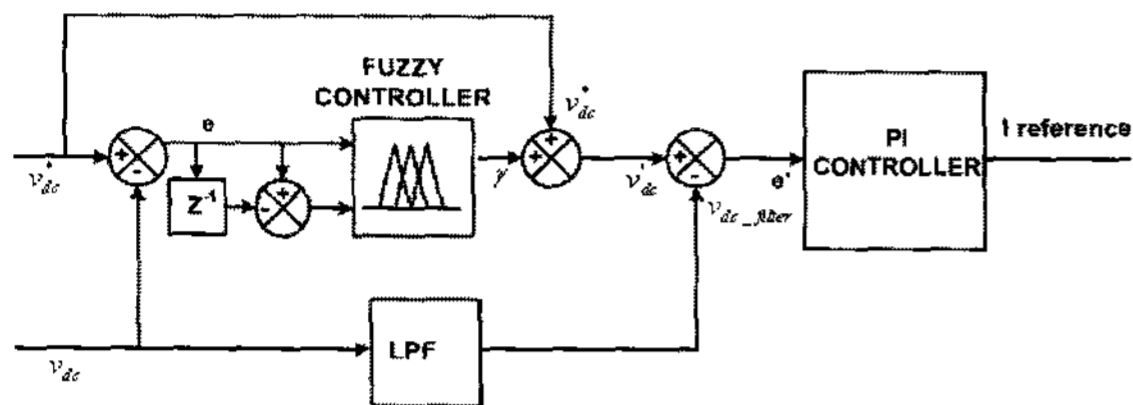

Fig. 3 Basic control scheme of fuzzy pre-compensated controller

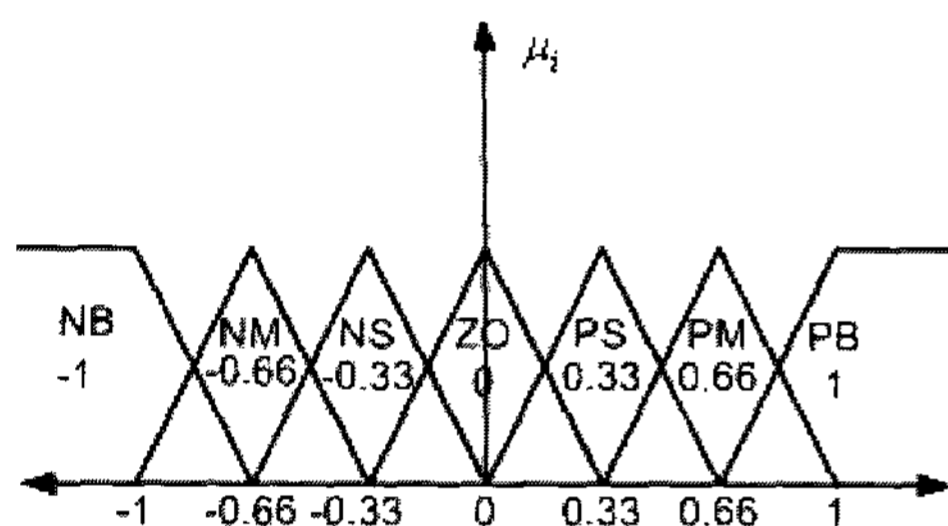

Fig. 4 Membership function for linguistic variables of L

$$\Delta e(k) = e(k) - e(k-1) \quad (4)$$

$$\gamma(k) = F[e(k), \Delta e(k)] \quad (5)$$

$$v_{dc}'(k) = v_{dc}^*(k) + \gamma(k) \quad (6)$$

For any such map F, there are seven linguistic variables (7) that are associated to them. These linguistic variables define the term set for the input and the output variables of F. The linguistic variables derive their notations from their mnemonics, i.e. 'NB' stands for Negative Big, 'PS' stands for Positive Small, and 'ZO' stands for Zero. Similarly for others, these mnemonics are defined.

$$L = \{NB, NM, NS, ZO, PS, PM, PB\} \quad (7)$$

Now associated with each of these linguistic variables is a collection of membership function (8) that maps from the real line to the interval $[0, 1]$ as shown in Fig. 4. This interval is called a fuzzy interval.

$$\mu = \{\mu_{NB}, \mu_{NM}, \mu_{NS}, \mu_{ZO}, \mu_{PS}, \mu_{PM}, \mu_{PB}\} \quad (8)$$

The realization process of $\gamma(k) = F[e(k), \Delta e(k)]$ is divided into three stages:

3.1 Fuzzification

This step is used to convert the errors and change in errors into fuzzy variables defined by L. For both errors and change in errors, numbers $n_e(l)$ and $n_{\Delta e}(l)$ is assigned given by (9) and (10). Here $C_{e(k)}$ and $C_{\Delta e(k)}$ are the scaling factors to bring down the errors and change in errors within the range $(-1, 1)$ respectively. These numbers will be used in the computation described later.

$$n_e(l) = \mu_l(C_e e(k)) \quad (9)$$

$$n_{\Delta e}(l) = \mu_l(C_{\Delta e} \Delta e(k)) \quad (10)$$

3.2 Decision Making

The decision making process is associated with a set of fuzzy logic rules. In accordance with the linguistic rules

Table 1 Logic Rules for Fuzzy Controller

$\Delta e(k)$ $e(k)$	NB	NM	NS	ZO	PS	PM	PB
NB	NB	NB	NM	NM	NS	NS	ZO
NM	NB	NM	NM	NS	NS	ZO	PS
NS	NB	NM	NS	NS	ZO	PS	PS
ZO	NM	NS	NS	ZO	PS	PS	PM
PS	NM	NS	ZO	PS	PS	PM	PM
PM	NS	ZO	PS	PS	PM	PM	PB
PB	NS	ZO	PS	PM	PM	PB	PB

and the linguistic values of the input of the fuzzifier, the linguistic values of the output are computed. As shown in Table 1, the first two linguistic values are associated with the input variables $e(k)$ and $\Delta e(k)$, while the third linguistic value is for the output. The linguistic value of the output corresponding to each set of inputs depends on the system. To decide each output value corresponding to every set of input, rigorous analysis is done with different combinations until the optimal table is obtained. Fig. 5 shows the realization of Table 1 as a surface map based on the linguistic variable definitions given in Fig. 4. The

surface map provides a qualitative idea of the behavior of the output for a different set of input conditions.

3.3 Defuzzification

The defuzzification process maps the result of the fuzzy logic rule stage to a real number output $\gamma(k) = F[e(k), \Delta e(k)]$. The height defuzzification method is used where, for each of the linguistic variable characterized by its membership function, the location of its peak defines a variable 'p'. Hence, $p(\text{NB}) = -1$, $p(\text{NM}) = -0.66$, $p(\text{NS}) = -0.33$, $p(\text{ZO}) = 0$, $p(\text{PS}) = 0.33$, $p(\text{PM}) = 0.66$, and $p(\text{PB}) = 1$ respectively. For each pair of linguistic variables shown in Table 1, another variable β_i is defined as in equation (11).

where, \wedge is the minimum operator. Then the final output of the defuzzification process is given as (12).

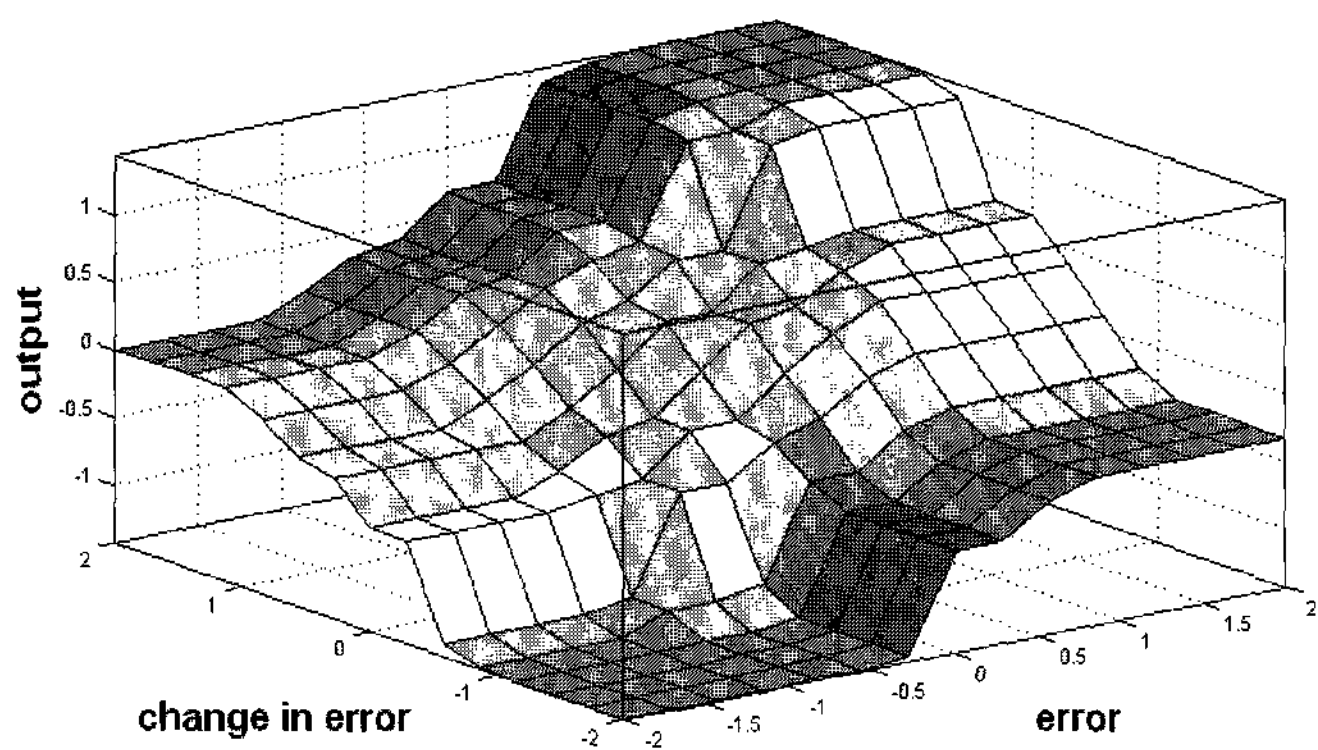

Fig. 5 Surface map of F

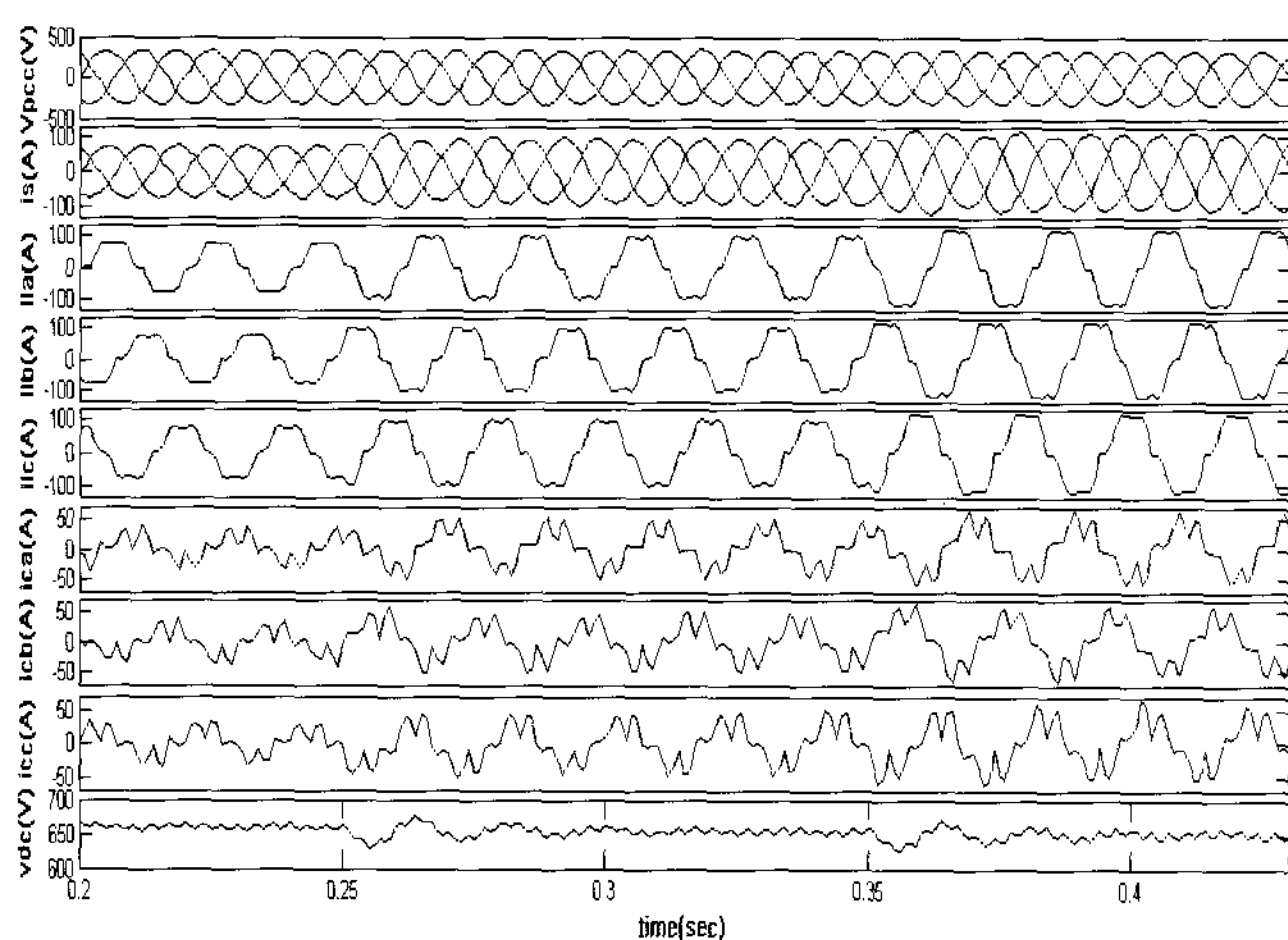

Fig. 6 Transient Performance of the system for simple PI controller for load changes from 10Ω to 6Ω and then to 5.12Ω at 0.25 sec and 0.35 sec respectively

$$\beta_i = \mu_1(C_e e(k)) \wedge \mu_1(C_{\Delta e} \Delta e(k)) \quad (11)$$

$$\gamma(k) = F[e(k), \Delta e(k)] = C_F \frac{\sum_{i=1}^{27} p(l_i) \beta_i}{\sum_{i=1}^{27} \beta_i} \quad (12)$$

where, $p(l_i)$ is the degree of belonging, β_i is the output of fuzzy subset, and C_F is the scaling factor.

4. Simulation Results

A three phase three wire system is modeled in the Matlab Simulink environment using Power Block Sets. A three wire system (as shown Fig. 1) is made up of standard three phase IGBT based VSI bridge with the input AC inductors, R-C filter and a DC bus capacitor to obtain a self supporting DC bus for an effective current control. The load is a 6-pulse diode rectifier fed R-L load. The system parameters are given in the Appendix.

4.1 Dynamic Performance of AF

The dynamic performance of AF is evaluated based on different factors:

4.1.1 Transient Response to Load Change

To get a measure of transient response, the system load is changed from 10Ω to 6Ω , then to 5.12Ω . Fig. 6 shows the variation of the DC link voltage V_{dc} for the PI controller alone and Fig. 7 shows the same variation using the fuzzy pre-compensated PI controller (FPC-PI). The values of K_p and K_i are set as 4 and 3.5 respectively.

It can be clearly seen from Figs. 6 and 7 that for the same load perturbations, the response of the AF system with the fuzzy pre-compensated PI controller settles very quickly. Moreover, it can be clearly noticed that due to time taken by the DC link voltage to settle in a simple PI controller case, the source current suffers unbalancing for a short duration, which is not present in the FPC-PI controller case. Table 2 shows a comparison between the peak overshoots and undershoots for the two systems and their settling times. The table infers that the AF system with the

Table 2 Dynamic Performance of APF for load change

System Controller	% Peak overshoot	% Peak undershoot	Settling time (cycles)
FPC-PI	0	3.08	0.5
PI	3.69	4.62	2.5

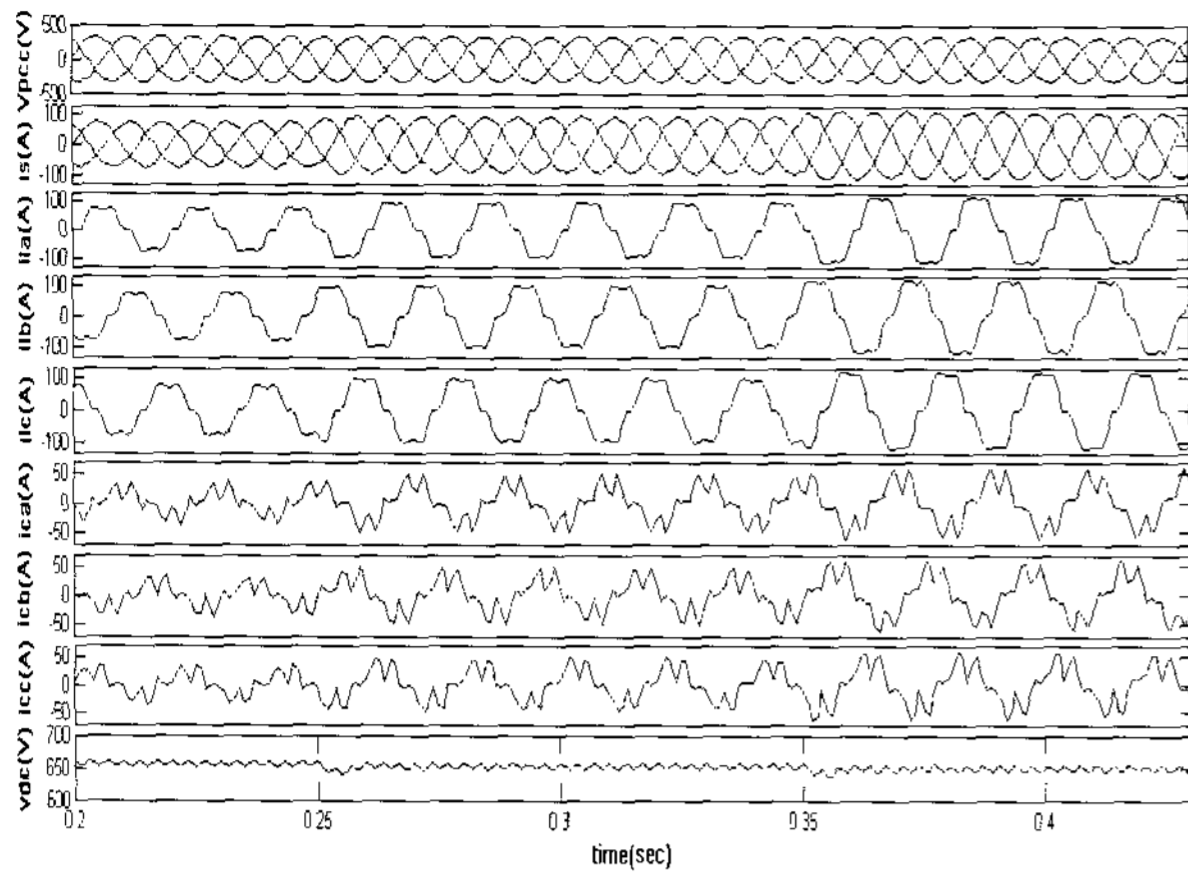

Fig. 7 Transient Performance of the system for fuzzy pre-compensated PI controller (FPC-PI) for load changes from 10Ω to 6Ω and then to 5.12Ω at 0.25 sec and 0.35 sec

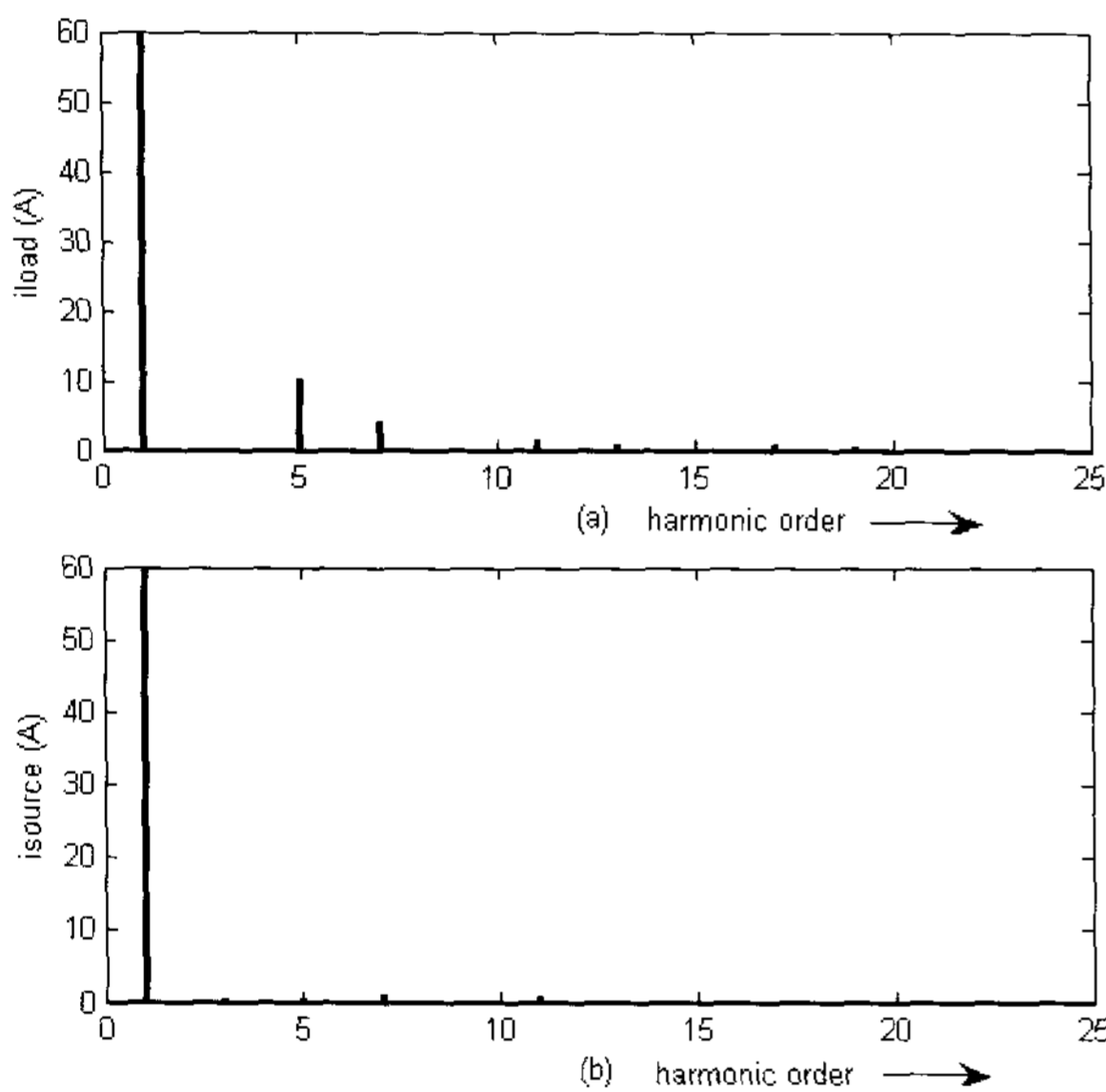

Fig. 8 Harmonic Spectrum of (a) Load Current (b) Source Current for a non-linear RL load using FPC-PI controller

FPC-PI controller does not have peak overshoot with the peak undershoot also less than a simple PI controller. Moreover, the settling time of the AF system with FPC-PI controller is less than the simple PI controller.

Fig. 8 shows the harmonic spectrum of the load current and the source current with the FPC-PI controller. The load current contains harmonics to the extent of 19.2 % whereas the source current harmonics are contained well within IEEE-519 limits to 2.55%.

4.1.2 Robustness to filter parameter variations

The filter parameters and the DC link voltage are the essential components that dictate the transient response to load perturbations. None of these components are ideal and suffer a variation in their values based on certain tolerance limits. The given FPC-PI controller is studied to these filter parameter variations as follows:

a) Coupling Inductance, L_c

Table 3 shows the variation of the THD and the settling time of the system for variations in coupling inductance from its set value of 2 mH. It can be clearly observed that the THD level for the entire extreme considered variations remains within IEEE – 519 recommended limits.

Table 3 Performance of Controller for variation in filter inductance

L_c (mH)	THD (%)	Settling time (cycles)
1.2	3.77	0.5
2	2.55	0.5
3.1	4.63	0.5

b) Filter Capacitance, C_c and Resistance, R_F

The capacitive filter C_c along with the resistance R_F is provided for improving the voltage profile at point of common coupling. As can be seen from Tables 4-5, the variations in these parameters have no substantial effect on AF performance.

Table 4 Performance of Controller for variation in filter capacitance

C_c (μF)	THD (%)	Settling time (cycles)
2	2.69	0.5
3.4	2.55	0.5
4.5	2.45	0.5

Table 5 Performance of Controller for variation in filter resistance

R_F (Ω)	THD (%)	Settling time (cycles)
2.1	3.37	0.5
3.5	2.55	0.5
5.2	2.18	0.5

c) Dc link Capacitor, C_{dc}

The DC link capacitor of the system is varied from 1500 μF to observe its performance. Table 6 shows the variation of THD and settling time with C_{dc} . It can be observed that, at as low of a value as 1000 μF , the DC link voltage settles down to stable value. However, the peak-to-peak amplitude of 6th Harmonic ripples in the DC link voltage increases by a factor of 2.

Table 6 Performance of Controller for variation in DC link Capacitor

C_{dc} (μF)	THD (%)	Settling time (cycles)
1000	2.59	0.5
1500	2.55	0.5
2000	2.22	0.5

4.1.3 Insensitivity to controller parameter variations

As it has been discussed earlier, the simple PI controller faces the problem of a rigorous hit and trial method to reach an optimal set of controller parameters. However, the FPC-PI controller is free of this drawback because of its insensitivity to controller parameter variations.

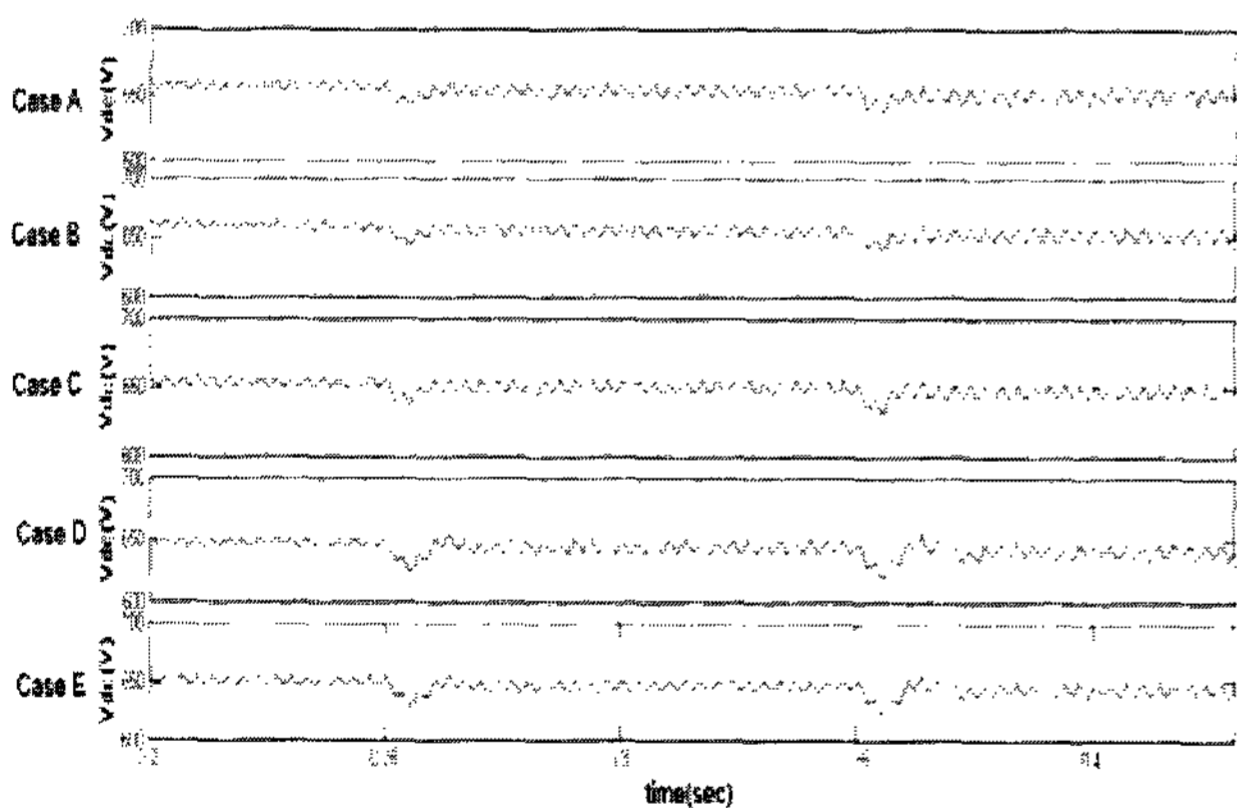

Fig. 9 Comparison of V_{dc} for FPC-PI controller with five different set of K_p and K_i as shown in Table 7

Table 7 shows the performance of the system for five sets of K_p and K_i chosen randomly near the set value. Fig. 9 shows the performance of the DC link voltage for these five sets. It can be inferred from the figure that the performance of the system has no effect due to controller parameter variations within limits. Only the settling time is increased to 1 cycle for some sets but that is even

acceptable. Hence, once the set of K_p and K_i are known at which the system settles for a simple PI controller, the FPC-PI controller makes it immune to any set of K_p and K_i near its vicinity. This eliminates the problem of rigorous tuning of the controller parameters.

Table 7 Comparison of performance of controller for variation in controller parameters

Case	K_p	K_i	Settling time (cycles)
A	4	3.5	0.5
B	4	4	0.5
C	3.5	3	0.5
D	3.5	3	1
E	3.5	3.5	1

4.2 Unity Power Factor Operation

Fig. 10 shows the variation of source current and voltage in phase A on the same axis to emphasize the unity power factor operation of the system during its steady state operation.

5. Conclusion

A technique has been proposed for the control of active filters using fuzzy pre-compensation of the reference DC link voltage of the AF. The complete design principles have been stated along with the parametric values used. Finally, the performance of the three-phase AF system is evaluated based on three factors: transient response to the load change, robustness to filter parameter variations, and insensitivity to controller parameters. The FPC-PI controller for the AF system has been found to show excellent performance in terms of stress on the DC link capacitor voltage and settling time. The FPC-PI controller for the AF system has been proven to eliminate the need for a rigorous hit and trial method to calculate controller parameters of the simple PI controller.

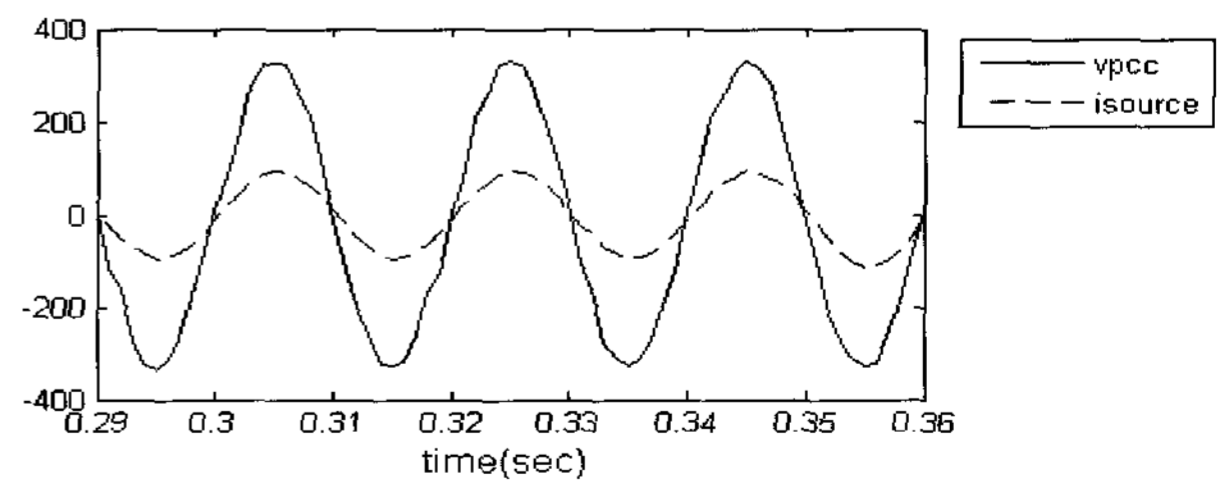

Fig. 10 Source current I_{sa} and voltage v_{sa} vs. time

Appendix

$V_s = 415$ V (line to line rms); $R_s = 0.1 \Omega$; $L_s = 0.2$ mH;
 $R_c = 0.1 \Omega$; $L_c = 2$ mH, $C_c = 3.4 \mu$ F; $R_f = 3.5 \Omega$;
 $C_{dc} = 1500 \mu$ F; $R_L = 5 \Omega$; $L_L = 15$ mH; $V_{dc}(\text{ref}) = 650$ V
 Switching frequency: 15 kHz, $C_{e(k)} = 0.1$, $C_{\Delta e(k)} = 0.1$,
 and $C_F = 2$

References

- [1] H. Akagi, Y. Kanazawa, and A. Nabae, "Instantaneous reactive power compensators comprising switching devices without energy storage components," *IEEE Trans. Ind. Applicat.*, Vol. IA-20, pp. 625–630, May/June 1984.
- [2] B. Singh, K. Al-Haddad, and A. Chandra, "A new control approach to three phase active filter for harmonics and reactive power compensation," *IEEE Trans. Power Syst.* Vol. 13, pp. 133-138, Feb. 1998.
- [3] B. Singh, K. Al-Haddad, and A. Chandra, "Active power filter with sliding mode control", in *Proc. of Inst. Elect. Eng., Generation, Transm., Distrib.*, Vol. 144, pp. 564–568, Nov. 1997.
- [4] M El-Habrouk and M.K. Darwish, "A new control technique for active power filters using a combined genetic algorithm/conventional analysis", *IEEE Trans on Industrial Electronics*, Vol. 49, No. 1, Feb. 2002.
- [5] M. Marinelli and A. Dell'Aquila, "Improved current control of active power filters using genetic algorithms"; in *Proc. of IEEE International Symposium on Ind. Elec.* 2004, Vol. 2, pp. 1447-1451, May 2004.
- [6] A. Chandra, B. Singh, B.N. Singh, and Kamal Al-Haddad, "An Improved Control Algorithm of Shunt Active Filter for Voltage Regulation, Harmonic Elimination, Power Factor Correction, and Balancing of Nonlinear Loads", *IEEE Trans on Power Elec.* Vol. 15, No. 3, May 2000.
- [7] Jong-Hwan Kim, Seon-Woo Lee and Kwang-Choon Kim, "Fuzzy Precompensation of PID controllers"; in *Proc. of IEEE Conf. On Control Applications*, Vol. 1, pp. 183-188, Sept. 1993.
- [8] Bhim Singh, B.P. Singh and Sanjeet Dwivedi; "DSP based implementation of fuzzy PI speed controller for vector controlled PMSM drive"; in *Proc. of 1st IEEE conf. On Industrial Electronics and Applications*, pp 1-6, May 2006.



Bhim Singh (SM'99) was born in Rahamapur, India in 1956. He received his B.E. electrical degree from the University of Roorkee, Roorkee, India in 1977, and his M.Tech. and Ph.D. degrees from the Indian Institute of Technology (IIT), New Delhi, India in 1979 and 1983, respectively. In 1983, he joined the Department of Electrical Engineering, University of Roorkee, as a Lecturer. He became a Reader there in 1988. In 1990, he joined the Department of Electrical Engineering, IIT, as an Assistant Professor. He became an Associate Professor in 1994 and Professor in 1997. His fields of interest include power electronics, electrical machines and drives, active filters, static var compensators, analysis, and digital control of electrical machines. Dr. Singh is a Fellow of the Indian National Academy of Engineering (INAE), Institution of Engineers (India), and Institution of Electronics and Telecommunication Engineers (IETE). He is also a Life Member of the Indian Society for Technical Education (ISTE), System Society of India (SSI), and the National Institution of Quality and Reliability (NIQR).



Varun Singhal was born in Sangroor, India in 1986. He has received his B. Tech degree in electrical engineering in power from Indian Institute of Technology (IIT), New Delhi, India in 2007. His fields of interest include power electronics, active filters, and control of electrical machines.