

# APPLICATION OF SEVERE ACCIDENT MANAGEMENT GUIDANCE IN THE MANAGEMENT OF AN SGTR ACCIDENT AT THE WOLSONG PLANTS

YOUNGHO JIN\*, SOO-YONG PARK and YONG-MANN SONG

Korea Atomic Energy Research Institute

1045 Deokdaero, Yuseong-Gu, Daejeon 305-353 KOREA

\*Corresponding author. E-mail : yhjin@kaeri.re.kr

*Received January 30, 2008*

*Accepted for Publication September 1, 2008*

---

A steam generator tube rupture (SGTR) accident, which is a partial reactor building bypass scenario, has a low probability and high consequences. SAMG has been used to manage the progression of severe accidents and the release of fission products induced by an SGTR at the Wolsong plants. Four of the six SAGs in the SAMG are used to manage the progression of a severe accident induced by an SGTR at the Wolsong plants. The results of the ISAAC code calculation have shown that the proper use of the SAMG can stop a severe accident from progressing and keep the reactor building intact during a severe accident. These results confirm that the SAMG is an effective means of managing the progression of severe accidents initiated by an SGTR at the Wolsong plants.

---

**KEYWORDS** : Severe Accident, Severe Accident Management, CANDU, Steam Generator Tube Rupture, SGTR

## 1. INTRODUCTION

A severe accident is an accident that exceeds design-based accidents and results in core damage. It is a rare event. The frequency of severe accidents is usually below  $10^{-4}$ /ry. If proper operator actions are not taken after the initiation of a severe accident in pressurized heavy water reactors, many fuel channels melt and relocate downward and the core is eventually disassembled. The core of such reactors consists of hundreds of horizontal fuel channels. Severe accidents may cause fission products to be released to the environment. Hence, it is important that the progression of a severe accident be managed properly and that the release of fission products into the environment be controlled effectively.

Severe accident management guidance (SAMG) for the CANDU 6 type of reactor was developed by KAERI [1]. This SAMG has a diagnostic flow chart (DFC) and six severe accident guidelines (SAGs). The DFC can be used to help select the most appropriate SAG for the current state of the plant. SAGs describe operator actions that may mitigate or terminate the progression of a severe accident and the release of fission products out of the reactor building. The six SAGs are as follows: (1) injection of water into the primary heat transport system (PHTS); (2) injection of water into the calandria vessel; (3) injection of water into the calandria vault; (4) reduction of a fission product release; (5) control of the reactor building condition;

and (6) reduction of the reactor building hydrogen concentration. Figure 1 shows the DFC and the six SAGs for the Wolsong plant, which is a CANDU 6 plant.

This paper demonstrates the effectiveness of the SAMG during the progression of a severe accident initiated by a steam generator tube rupture (SGTR) accident in the Wolsong plants. The frequency of severe core damage for an SGTR accident is very low: namely  $5 \times 10^{-9}$ /ry for the Wolsong 2 Station [2]. In this report, severe core damage is defined as the collapse of fuel channels within the calandria vessel. An SGTR accident is a partial reactor building bypass scenario. From ruptured steam generator tubes, fission products may be released directly into the environment instead of inside the reactor building until the calandria vessel fails, even though the reactor building is intact. This behavior is why an SGTR accident was selected to demonstrate the SAMG effectiveness, in spite of the low frequency of this type of accident.

The accident progression, including the operator actions, is evaluated using ISAAC (Integrated Severe Accident Analysis Code for a CANDU6 plant) computer code [3].

## 2. PLANT MODELING

ISAAC simulates an accident progression from normal full-power conditions to the failure of the reactor building. The code has models for the following: a reactor trip, an

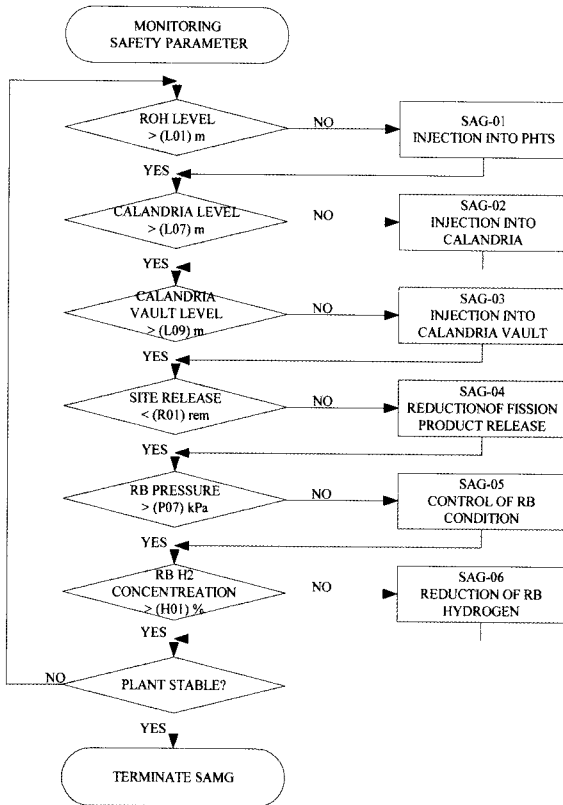

Fig. 1. Diagnostic Flow Chart of the Generic SAMG of the Wolsong Plants (Part of the DFC)

inventory blow-down or boil off, a core heat up, cladding oxidation, fuel melting and a fuel channel failure, a calandria vessel failure, a calandria vault failure due to core-concrete

interaction, and a reactor building failure. The code can also model the hydrogen distribution and combustion, and the fission products release and transport in the reactor building.

### 2.1 PHTS Nodalization

The PHTS is represented by two symmetric loops and the flow through each loop follows a figure eight configuration. The two loops, which are connected through a pressurizer, are isolated when the motor-operated valves are closed; the valves are on each line that connects a loop and a pressurizer.

As shown in Fig. 2, each loop consists of two SGs, two PHTS pumps, two reactor inlet headers, two reactor outlet headers (ROHs), two pump discharge lines, and two pump suction lines.

A CANDU 6 core has 380 horizontal fuel channels arranged in 22 rows and 22 columns. ISAAC can divide the 380 channels into a maximum of 74 nodes by considering the channel elevation and power distribution. In this analysis, the 22 fuel channel rows were divided into six vertical nodes and the 22 columns of a fuel channel were divided into two PHTS loops, which were symmetrical about a vertical mid-core plane. The 12 fuel bundles in a CANDU fuel channel were modeled as 12 axial channel nodes. In a fuel channel, the calandria tube and the pressure tube are modeled as two concentric rings. The 37 fuel elements of the fuel bundle are modeled as seven concentric rings. Thus, nine rings represent a CANDU 6 fuel channel.

### 2.2 Reactor Building Nodalization

ISAAC has a generalized reactor building model that resembles the MAAP4 code. The reactor building volume

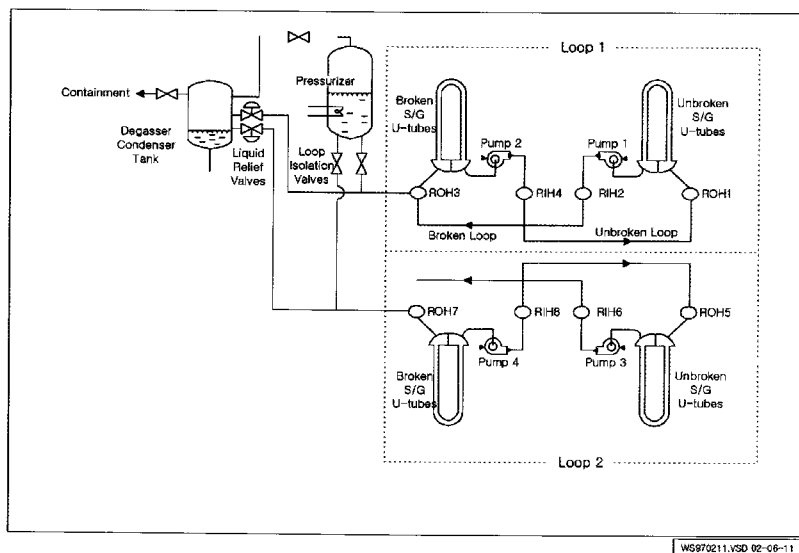

Fig. 2. ISAAC Modeling for the PHTS

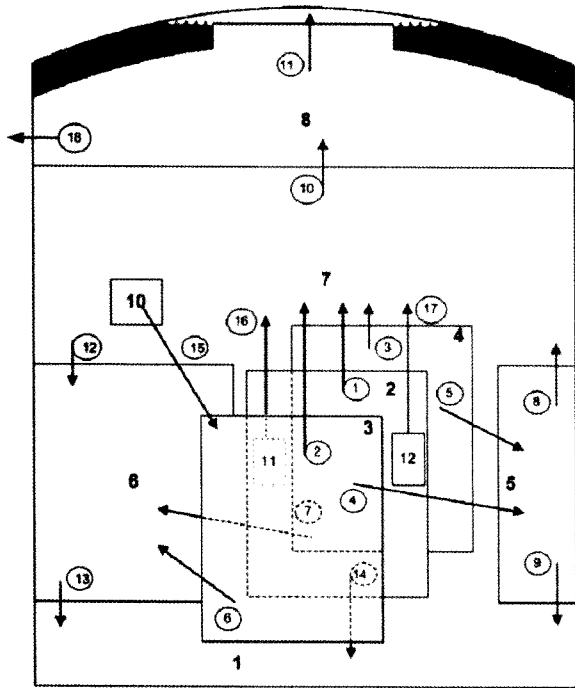

Fig. 3. ISAAC Modeling of the Reactor Building

is represented by the following 12 nodes: a basement (1), a calandria vault (2), two fuel machine rooms (3 and 4), a moderator room (5), an access area (6), a steam generator room (7), an upper dome (8), a dousing tank (9), a degasser condenser tank (10), and two end shields (11 and 12). The node numbers are expressed in bold type in Figure 3. These nodes are connected by 18 flow junctions. The junction numbers are denoted as circles. Figure 3 shows a schema of the reactor building nodalization used in this analysis.

### 3. ANALYSIS OF AN ACCIDENT PROGRESSION

#### 3.1 Base Case

##### 3.1.1 Analysis Assumptions

The results of an accident analysis depend on the assumptions used in the analysis because a severe accident analysis code has models for very complex physical and chemical phenomena. For these phenomena, best estimate assumptions are used except when data for certain processes are not available.

The assumptions regarding the availability of systems are as follows:

- The initiating event is an SGTR event. Ten tubes are assumed to experience guillotine breaks, and the corresponding break area is 0.0029 m<sup>2</sup>. The break location is set at the top of the SG tubesheet in PHTS loop 1.

- The reactor is shutdown when the PHTS pressure is less than 8.7 MPa.
- The emergency core cooling systems (ECCSs) are not available.
- The moderator cooling system is not available.
- The end shield cooling system is not available.
- The shutdown cooling system is not available.
- The main and auxiliary feedwater systems are not available.
- The crash cooldown system is available; the main steam safety valves (MSSVs) are opened 30 seconds after a signal for a loss of coolant accident (LOCA).
- Two PHTS loops are isolated 20 seconds after a signal for a loop isolation.
- Atmospheric steam discharge valves and condenser steam discharge valves are not modeled because they are located downstream after the main steam isolation valves, which are closed.
- The reactor building dousing spray system is available.
- The local air coolers (LACs) and reactor building ventilation systems are not available.
- The hydrogen igniters are available.
- The reactor building ruptures if the reactor building pressure exceeds 520 kPa.
- All operator interventions are not credited.

##### 3.1.2 Results and Discussion

The major events which occurred are summarized in Table 1.

The pressure in the PHTS and SG pressures are shown in Figures 4 and 5, respectively. The PHTS pressure decreases as a result of a loss of coolant through the ruptured SG tubes and reaches the set pressure of a reactor trip at 58 seconds. The pressure of loop 1 decreases continuously due to a loss of coolant through the ruptured steam

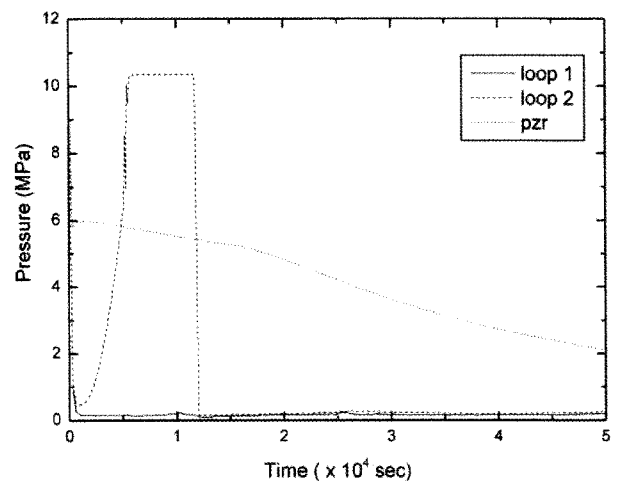

Fig. 4. Pressure in the PHTS Loops and the Pressurizer

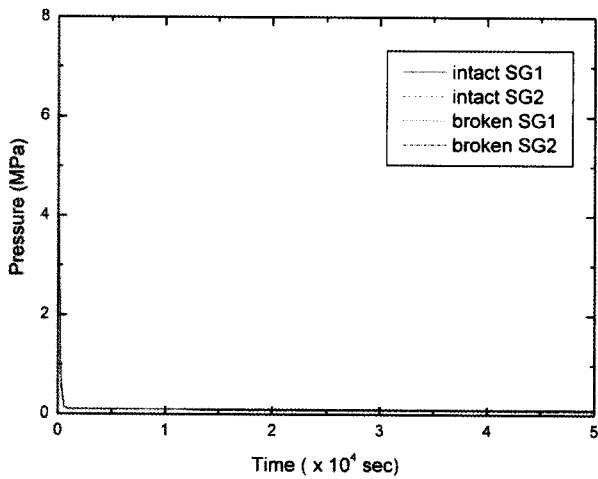

Fig. 5. Pressure of the Secondary Side of the Four SGs in the Two Loops

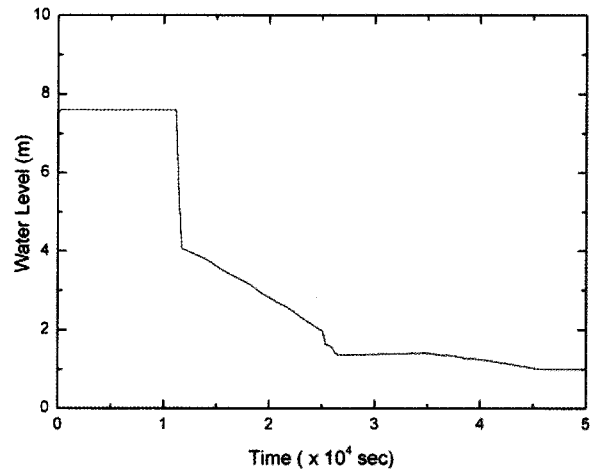

Fig. 6. The Collapsed Water Level in the Calandria Vessel

generator tubes and a low pressure of the loop 1 generates a LOCA signal at 152 seconds. A loop isolation signal is generated at the same time, and it isolates two loops from a pressurizer. The crash cooldown starts 30 seconds after a LOCA signal is generated. As the secondary side SG pressure decreases rapidly, as shown in Figure 5, the pressure of loop 1 also decreases rapidly and remains the same as the SG pressure. The pressure of loop 2 shows the same behavior as the pressure of loop 1 until the SGs dry out. After a dry out of the unbroken loop steam generators, the pressure of loop 2 increases and reaches the opening pressure of the liquid relief valves; it then oscillates until the pressure tubes rupture. After the pressure tubes are ruptured by a creep at 11,795 seconds, the pressure decreases rapidly and remains the same as the pressure of the calandria. The pressurizer is isolated from the loops after a loop isolation signal is generated. Thus, the pressure behavior of the pressurizer is different from that of the loops. The pressure of the pressurizer decreases gradually after the loop isolation.

The pressures of the four SGs are shown in Figure 5. Given the assumption that an auxiliary feedwater system is unavailable, no water is delivered to the SGs after a reactor trip. A LOCA signal requests a crash cooldown operation and all the MSSVs are opened. As a result, the pressure of the SGs decreases rapidly and remains close to atmospheric pressure.

The moderator temperature and pressure in the calandria vessel increase as a result of a heat transfer from the core and a loss of moderator cooling following the initiating event. When the pressure difference between the inside of the calandria vessel and the reactor building reaches the rupture disk set point, the rupture disks burst. Just after the rupture disks burst, the moderator discharges into the reactor building through the relief ducts. This results in a rapid decrease of the moderator level in the calandria

vessel, as shown in Figure 6. After that, the moderator level falls slowly due to a boil-off into the reactor building.

Figure 7 shows the water level in the calandria vault during the progression of the accident. The water temperature in the calandria vault increases gradually after the initiating event, due to a loss of end shield cooling and moderator cooling, which are initially assumed. This increase in water temperature results in an increase of the water level and the calandria vault becomes solid at 36,971 seconds. When the calandria vault becomes solid, the calandria vault rupture disks burst. After the rupture disks burst, the water boils off and the water level decreases. When the water level falls below the debris level inside the calandria vessel, the calandria vessel wall heats up and fails due to a creep at 138,603 seconds.

Figure 8 shows the pressure history of the reactor

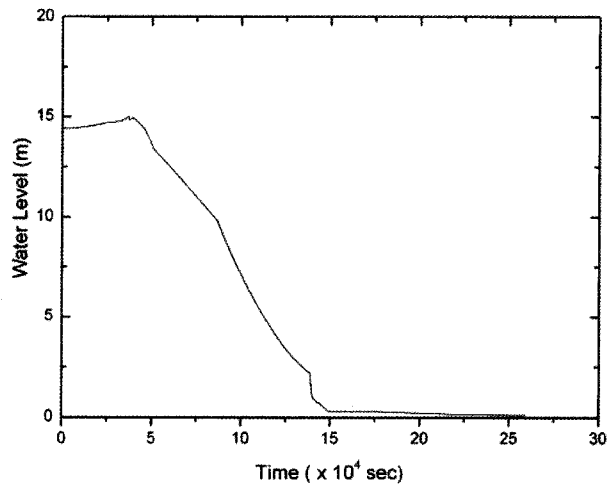

Fig. 7. The Collapsed Water Level in the Calandria Vault

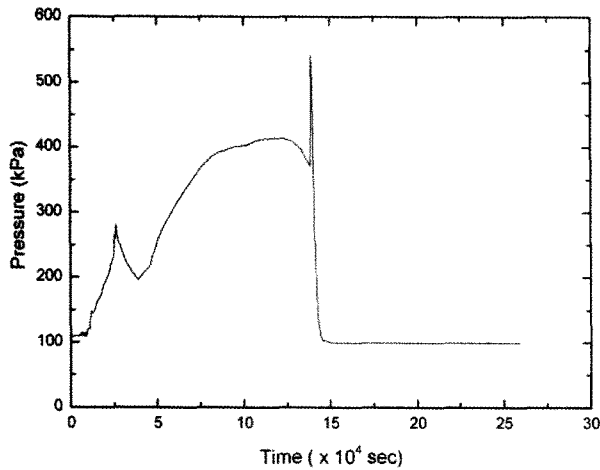

Fig. 8. The Reactor Building Pressure

building. After the failure of the rupture disks in the calandria vessel, the reactor building pressure increases. The steam generated in the calandria vault is released to the reactor building atmosphere through the rupture disks. The reactor building pressure increases until the calandria vessel dries out. After the calandria vessel has dried out, no steam is added to the reactor building atmosphere. As a result, the reactor building pressure decreases smoothly. After the burst of the rupture disks in the calandria vault, the reactor building pressure increases again until the water level falls below the top level of the corium in the calandria vessel. After that, the reactor building pressure decreases gradually until the water level falls below the bottom of the calandria vessel. As the calandria vessel is uncovered and fails, the corium falls into the calandria

vault. The falling hot corium makes contact with water in the vault and generates steams rapidly, causing a spike in the reactor building pressure. The reactor building then fails due to the high reactor building pressure.

Figure 9 shows the fraction of the noble gases and CsI released to the environment for the base case. Fission products are released out of the reactor building, even though the reactor building is intact. The opened MSSVs are the main route. About 40% of the noble gases is released out of the reactor building before the core collapse. After the core collapse, an additional 12% of the noble gases is released; furthermore, when the reactor building has failed, the remaining noble gases are released.

About 11% of CsI is released until the core collapses. The additional release of CsI after the collapse of the core is negligible.

### 3.2 Plant Responses with Mitigation Actions

The entry conditions to the SAMG are reached at 11,507 seconds. So the technical support center staff order operators to terminate the use of emergency operating procedures and start to use the SAMG.

Thus far, four plant safety parameters (the ROH level, the calandria level, the site release, and the reactor building pressure) have exceeded the set point prescribed in the DFC. As mentioned above, fission products are released through the opened MSSVs.

The first operator action is the following:

**Operator action 1: Close the MSSV 30 minutes after an SAMG entry (13,307 seconds).**

As the dose at the site boundary exceeds its set value, SAG-04 is selected by the DFC. The operator action is described in SAG-04.

Figure 10 shows the release of fission products into the environment with this operator action. The closure of the

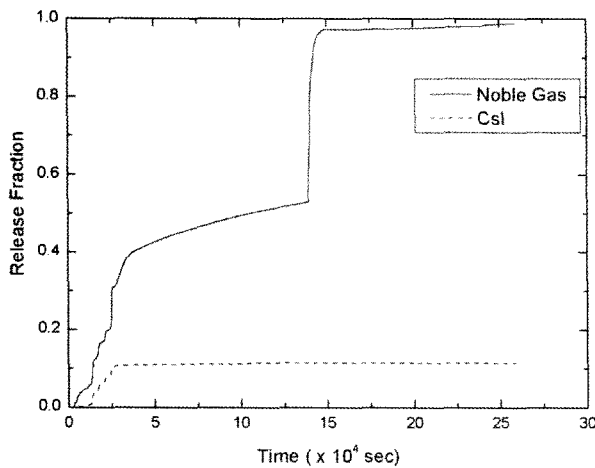

Fig. 9. The Fraction of Noble Gases and CsI Released to the Environment for the Base Case

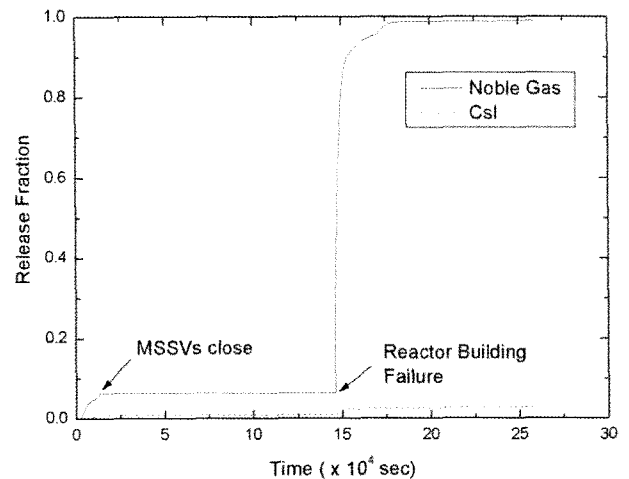

Fig. 10. The Fraction of Noble Gases and CsI Released into the Environment with Operator Action 1

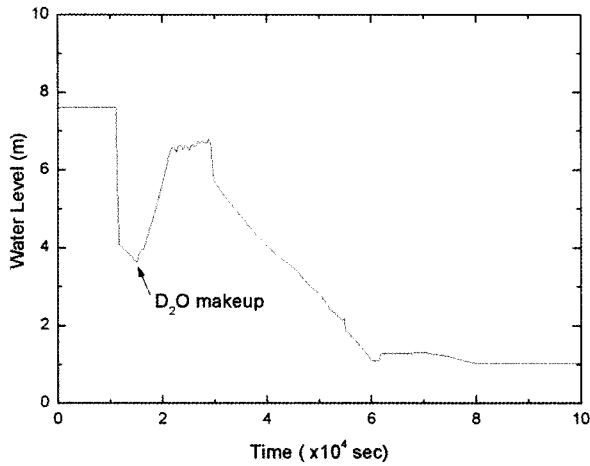

Fig. 11. The Collapsed Water Level in the Calandria Vessel with Operator Actions 1 and 2

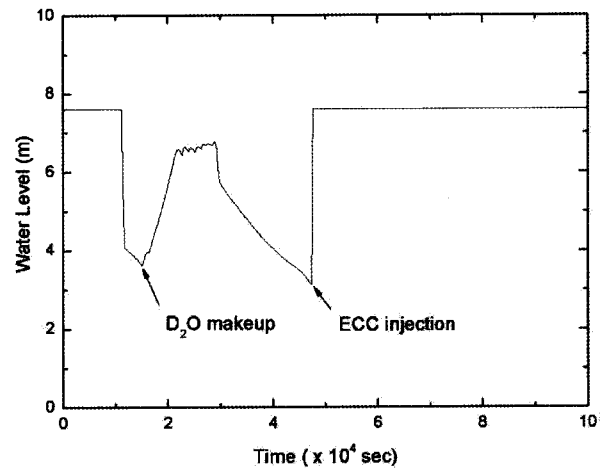

Fig. 13. The Collapsed Water Level in the Calandria Vessel with Operator Actions 1, 2 and 3

MSSVs terminates the release of fission products through the MSSVs. The secondary pressure cannot reach the opening set pressure of the MSSVs because there is no water in the secondary side of the SGs at this time.

The second operator action is the operation of the D<sub>2</sub>O supply pump. This action enables a supply of water into the calandria vessel.

**Operator action 2: Supply D<sub>2</sub>O from the D<sub>2</sub>O storage tank to the calandria vessel by using the D<sub>2</sub>O supply pump 1 hour after a SAMG entry (15,107 seconds).**

As the moderator level falls below its set value, SAG-02 is selected by the DFC. The D<sub>2</sub>O supply pump is assumed to be available at this time.

As the D<sub>2</sub>O is supplied to the calandria vessel, the water level increases in the calandria vessel, as shown in

Figure 11. After the depletion of the D<sub>2</sub>O supply tank, the water level starts to drop. As the moderator level decreases below the fuel channels, the temperature of the uncovered fuel channel increases. If an additional recovery action is not taken, the core will melt down and the core will collapse in loop 1 and loop 2 at 54,573 seconds and 61,546 seconds, respectively.

The water level in the calandria vault shows similar behavior to the base case, as shown in Figure 12. After a core collapse, the heat generated in the corium is transferred to the water in the calandria vault through the calandria vessel wall. This transfer of heat causes the water level in the calandria vault to fall.

As shown in Figures 11 and 12 an additional operator action is required to terminate a severe accident progression

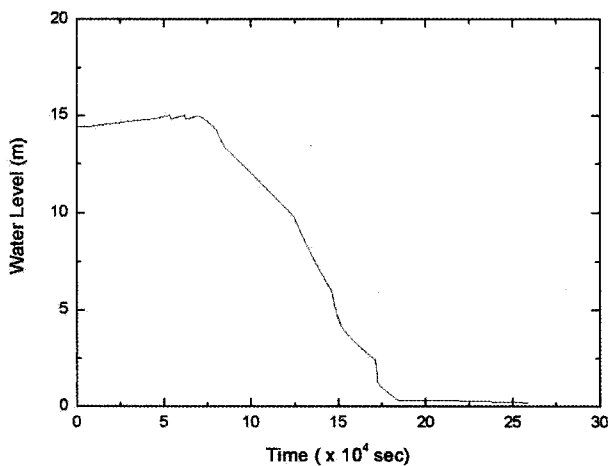

Fig. 12. The Collapsed Water Level in the Calandria Vault with Operator Actions 1 and 2

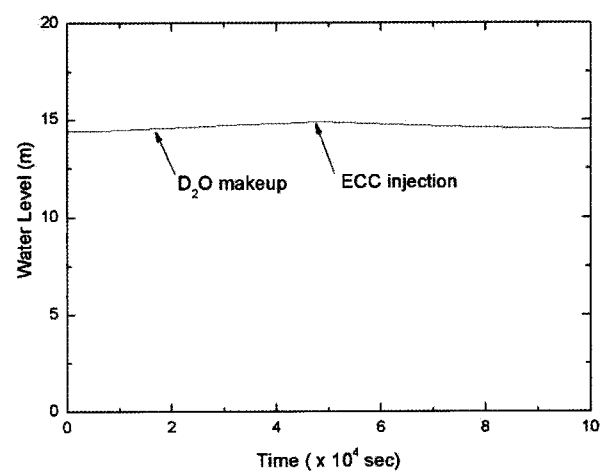

Fig. 14. The Collapsed Water Level in the Calandria Vault with Operator Actions 1, 2 and 3

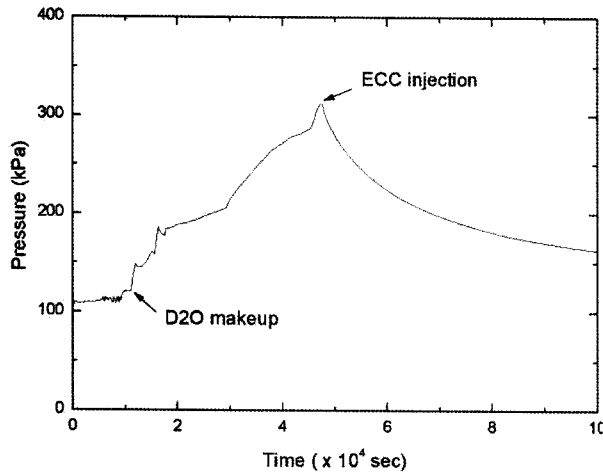

Fig. 15. The Pressure in the Reactor Building Dome with Operator Actions 1, 2 and 3

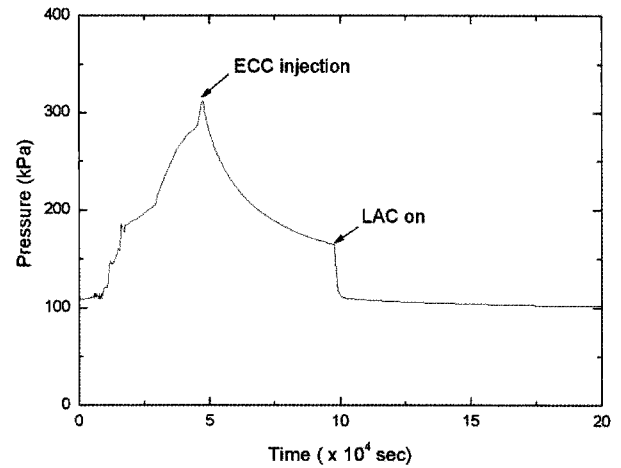

Fig. 16. The Pressure in the Reactor Building Dome with Operator Actions 1, 2, 3 and 4

and to make the plant stable. Hence, it is assumed that the ECCS is recovered 10 hours after a SAMG entry.

**Operator action 3: The ECCS is recovered 10 hours after an SAMG entry (47,507 seconds)**

As the ROH water level falls below its set value, SAG-01 is selected by the DFC. The ECCSs are assumed to become available at this time.

As the ECCS operates, the water level increases and the calandria vessel becomes filled with water, as shown in Figure 13. The core is cooled and the heat transfer from the calandria vessel to the calandria vault is reduced. As a result, the water temperature in the vault decreases and the water level decreases, as shown in Figure 14.

As the water level in the calandria vault decreases due to a subcooling of the water, the flow from the vault to the reactor building atmosphere stops. Hence, the reactor building pressure starts to decrease after the start of the ECCS, as shown in Figure 15.

The operation of the ECCS helps reduce the reactor building pressure and prevents a reactor building failure due to overpressurization. However, the operation of the ECCS cannot cause the reactor building pressure to drop below the set point of a reactor building isolation. Hence, there is a need for an operator action that can adequately reduce the reactor building pressure.

**Operator action 4: LACs in the fuel machining room are recovered at 24 hours after an SAMG entry (97,907 seconds).**

As the pressure in the reactor building exceeds its set value, SAG-05 is selected by the DFC. It is assumed that the LACs are recovered at this time.

The reactor building pressure decreases sharply just after the operation of the LACs. After an initial pressure drop, the reactor building pressure decreases smoothly and finally falls below the set point of a reactor building isolation.

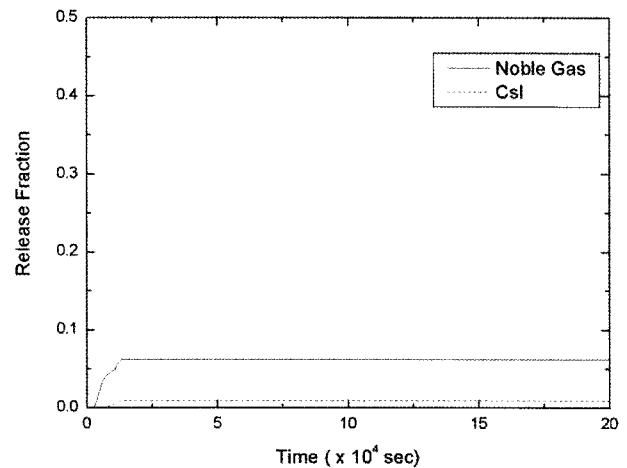

Fig. 17. The Fraction of Noble Gases and CsI Released into the Environment with Operator Actions 1, 2, 3 and 4

However, fission products are released before an operator action is taken. After the operator closes the MSSVs (operator action 1), no more fission products are released out of the reactor building, as shown in Figure 17.

As the important plant parameters (the water level in the calandria, the reactor building pressure, and the fission products release rate) become lower than the prescribed values, the plant is considered to be in a stable, controllable state.

**4. CONCLUSION**

The SAMG was used to manage a severe accident progression induced by an SGTR at the Wolsong plants.

**Table 1.** The Times of the Major Events, with and without Severe Accident Management

	Base Case (seconds)	With SAMG (seconds)
Reactor scram	58	58
LOCA signal generated	152	152
Core uncover (loop 1)	1,652	1,652
SG dry (loop 2)	2,496	2,496
Dousing spray starts	5,862	5,862
Core uncover (loop 2)	8,090	8,090
Dousing tank deleted for spray	9,157	9,157
CTK rupture valve open	11,398	11,398
<b>SAMG entry condition</b>	<b>11,507</b>	<b>11,507</b>
Pressure tube rupture (loop 2)	11,795	11,795
<b>SG MSSV Close<sup>1)</sup></b>	-	<b>13,307</b>
Pressure tube rupture (loop 1)	13,340	13,337
Corium relocation start (loop 1)	13,441	13,409
Corium relocation start (loop 2)	14,115	14,139
<b>D2O make up<sup>2)</sup></b>	-	<b>15,107</b>
Core collapsed (loop 1)	24,812	-
Core collapsed (loop 2)	26,000	-
No water in CTK	26,942	-
<b>ECC on<sup>3)</sup></b>	-	<b>47,507</b>
<b>LAC turn on<sup>4)</sup></b>	-	<b>97,907</b>
Calandria vessel failed	138,603	-
R/B failure	139,149	-
End of calculation	259,200	259,200

<sup>1)</sup>Operator action described in SAG-04

<sup>2)</sup>Operator action described in SAG-02

<sup>3)</sup>Operator action described in SAG-01

<sup>4)</sup>Operator action described in SAG-05

ISAAC was used to evaluate the plant responses during the progression of a severe accident.

Four of six SAGs in the SAMG were used to manage a severe accident progression induced by an SGTR at the Wolsong plants. The result of the ISAAC calculation shows that proper use of the SAMG can terminate a severe accident progression, keep the reactor building intact during a severe accident, and reduce the amount of fission products released into the environment. Thus, the SAMG is an effective means of managing a severe accident progression initiated by an SGTR at the Wolsong plants.

The emergency operation procedure requests an early crash cooldown of the primary system for an SGTR accident. The closure of the MSSVs after the initiation of a severe accident can significantly reduce the amount of fission products released out of the reactor building during

an SGTR accident. Thus, an additional operator action that closes the MSSVs is recommended in the **emergency operating procedures** if the ECCS is not available.

## ACKNOWLEDGEMENTS

This study was undertaken as part of the nuclear R&D program of the Korean Ministry of Science and Technology.

## REFERENCES

- [ 1 ] "Severe Accident Management Guidance for Pressurized Heavy Water Reactors," KAERI/TR-3284/2006, 2006
- [ 2 ] "Probabilistic safety Assessment for Wolsong Units 2,3,4," Korea Hydro & Nuclear Co., Ltd, 2007
- [ 3 ] "ISSAC Computer Code User's Manual," KAERI/TR-3645/2008, 2008