

# Generation and Expression in Plants of a Single-Chain Variable Fragment Antibody Against the Immunodominant Membrane Protein of *Candidatus Phytoplasma Aurantifolia*

F. Shahryari<sup>1,2</sup>, M.R. Safarnejad<sup>2,3</sup>, M. Shams-Bakhsh<sup>1</sup>, S. Schillberg<sup>4\*</sup>, and G. Nölke<sup>4</sup>

<sup>1</sup>Department of Plant Pathology, Faculty of Agriculture, Tarbiat Modares University, Tehran, Iran

<sup>2</sup>Department of Microbial Biotechnology and Biosafety, Agricultural Biotechnology Research Institute, Karaj, Iran

<sup>3</sup>Department of Plant Viruses, Iranian Research Institute of Plant Protection, Tehran, Iran

<sup>4</sup>Fraunhofer Institute for Molecular Biology and Applied Ecology (IME), 52074 Aachen, Germany

Received: January 21, 2013

Revised: March 21, 2013

Accepted: March 22, 2013

First published online  
June 3, 2013

\*Corresponding author

Phone: +49-241-6085-11050;

Fax: +49-241-6085-10000;

E-mail: stefan.schill-

berg@ime.fraunhofer.de

pISSN 1017-7825, eISSN 1738-8872

Copyright© 2013 by  
The Korean Society for Microbiology  
and Biotechnology

Witches' broom of lime is a disease caused by *Candidatus Phytoplasma aurantifolia*, which represents the most significant global threat to the production of lime trees (*Citrus aurantifolia*). Conventional disease management strategies have shown little success, and new approaches based on genetic engineering need to be considered. The expression of recombinant antibodies and fragments thereof in plant cells is a powerful approach that can be used to suppress plant pathogens. We have developed a single-chain variable fragment antibody (scFvIMP6) against the immunodominant membrane protein (IMP) of witches' broom phytoplasma and expressed it in different plant cell compartments. We isolated scFvIMP6 from a naïve scFv phage display library and expressed it in bacteria to demonstrate its binding activity against both recombinant IMP and intact phytoplasma cells. The expression of scFvIMP6 in plants was evaluated by transferring the scFvIMP6 cDNA to plant expression vectors featuring constitutive or phloem specific promoters in cassettes with or without secretion signals, therefore causing the protein to accumulate either in the cytosol or apoplast. All constructs were transiently expressed in *Nicotiana benthamiana* by agroinfiltration, and antibodies of the anticipated size were detected by immunoblotting. Plant-derived scFvIMP6 was purified by affinity chromatography, and specific binding to recombinant IMP was demonstrated by enzyme-linked immunosorbent assay. Our results indicate that scFvIMP6 binds with high activity and can be used for the detection of *Ca. Phytoplasma aurantifolia* and is also a suitable candidate for stable expression in lime trees to suppress witches' broom of lime.

**Keywords:** Lime, phage display, recombinant antibody, transient expression, witches' broom of lime

## Introduction

Lime (*Citrus aurantifolia*) is an important agricultural crop in many countries surrounding the Persian Gulf, but major losses are caused by diseases such as witches' broom of lime. The symptoms include small chlorotic leaves, rapidly proliferating shoots, and short internodes, causing the plant to die within 3–4 years. Witches' broom of lime is caused by *Candidatus Phytoplasma aurantifolia*, which is

naturally transmitted by the leafhopper *Hishimonus phycitis* Distant [26]. Phytoplasmas are wall-less, phloem-restricted bacterial pathogens of the class Mollicutes that persistently colonize their plant hosts [31]. Witches' broom of lime was first found in Oman in 1975 [2] and more than 98% of lime trees in the region became infected over the next four decades [3]. The disease was also reported in the Iranian provinces of Sistan and Baluchestan in 1997, destroying approximately 30% of the local Mexican lime trees over the

next 15 years and significantly impacting on lime production [13].

There are no natural sources of resistance against witches' broom of lime, and traditional methods such as the eradication of infected trees and the control of insect vectors have not been successful. Alternative approaches including genetic engineering should therefore be considered. Resistance induced by the expression of recombinant antibodies can be used to suppress several viral, bacterial, and fungal plant pathogens [10, 15, 18, 23–25, 30, 33], so this could also be considered as potential strategy to tackle *Ca. Phytoplasma aurantifolia*.

Single-chain variable fragments (scFvs) comprise the variable domains of the heavy and light chains of a parental monoclonal antibody connected by a short linker peptide [1, 4]. This is the smallest immunologically active molecule that can replicate the binding specificity of its parent. These fragments can be functionally expressed in plants and directed to any compartment of the plant cell, including the cytosol [5].

The efficient control of plant pathogens using recombinant antibodies requires the targeting of antibody fragments to any plant cell compartment in which the pathogen exposes a vulnerable and accessible surface protein that can be used for neutralization. Phytoplasma display cell-surface immunodominant membrane proteins (IMPs) that are in direct contact with the host cell environment [14] and which play important roles in pathogenicity in host plants and insect vectors [7]. IMPs are therefore excellent targets for the antibody-mediated resistance approach. We have generated scFvs that target *Ca. Phytoplasma aurantifolia* IMPs and expressed them in model plants as a first step towards an antibody-mediated resistance strategy for deployment in lime trees.

## Materials and Methods

### Plasmid DNA, Bacteria, and Plants

The IMP gene was previously isolated from the total DNA of lime witches' broom infected Mexican lime plants and cloned in the bacterial expression vector pET-28a [29]. We used this pET28-IMP construct to express recombinant IMP in *Escherichia coli*. The scFv constructs isolated from the phage display library were inserted into the expression vector pTRA [21] and introduced into *Agrobacterium tumefaciens* strain GV3101 (pMP90RK, Gm<sup>R</sup>, Km<sup>R</sup>, Rif<sup>R</sup>) [8] for transient expression in *Nicotiana benthamiana* plants.

Phytoplasma from an infected lime plant (kindly provided by Dr. Mohsen Mardi, ABRIL, Karaj, Iran) was maintained by serial graft transmission from infected to healthy lime plants. All plants were maintained in an insect-proof greenhouse.

### Screening Phage Display scFv Libraries

Phytoplasma-specific scFvs were isolated by using a purified recombinant IMP expressed in *E. coli* [29] to screen the Tomlinson I and J scFv phage display libraries, as previously described [27]. Recombinant IMP (50 µg/ml) was immobilized onto immunotubes (Nunc-Maxisorp, Denmark), blocked with 2% (w/v) skimmed milk, and incubated with the phage suspension (10<sup>13</sup> CFU). Phage particles eluted from the tubes by addition of 100 µmol triethylamine were amplified in exponentially growing *E. coli* TG1 cells for three rounds of panning, and individual clones randomly selected following the third round were tested for binding specificity by enzyme-linked immunosorbent assay (ELISA) against recombinant IMP using scFv-expressing phages or soluble scFv fragments. The soluble scFv fragments were expressed in *E. coli* strain HB2151, after induction with 1 mM isopropyl-β-D-thiogalactopyranoside (IPTG) at 30°C overnight. Soluble scFv was recovered by centrifugation and the supernatant was used for serological analysis. The binding activity of each scFv against IMP was tested by ELISA and immunoblotting, as previously described [22].

### Expression Construct Design

The scFvIMP6 cDNA was introduced into plant expression vector pTRA using the *Nco*I and *Not*I restriction sites, creating an expression cassette featuring the doubled enhanced *Cauliflower mosaic virus* (CaMV) 35S promoter, the 5' untranslated region (UTR) from the *Petroselinum hortense* chalcone synthase gene, and the leader peptide sequence from the murine antibody 24 heavy chain (mAb24 LPH) [32]. The final vector was named pTRA-35S-LPH:scFvIMP6 and was used to express scFvIMP6 in the apoplast of *N. benthamiana* leaves (Fig. 1A).

To express scFvIMP6 in the phloem, the CaMV 35S promoter was replaced with the phloem-specific *Coconut foliar decay virus* (CFDV) promoter [20] from the pTRA-CFDV:scFvLR3cp-1 vector [17]. The CFDV promoter-cDNA was inserted using the *Asc*I and *Eco*RI restriction sites, to create vector pTRA-CFDV-LPH:scFvIMP6 (Fig. 1B).

An additional construct was generated for cytosolic accumulation under the control of the phloem-specific CFDV promoter. The scFvIMP6-tag54/His<sub>6</sub> tag sequence was inserted into the pTRA-pat-CFDV vector using the *Nco*I and *Xba*I restriction sites. The complete cassette was then excised using *Asc*I and *Bam*HI and inserted into the corresponding sites of pTRAKt-GFPperox. The final construct (pTRA-CFDV-Ω:scFvIMP6) contained the phloem-specific CFDV promoter and the *Tobacco mosaic virus* (TMV) 5' untranslated region (Ω leader), but no leader peptide sequence (Fig. 1C).

A tag54 [19] and His<sub>6</sub> tag was included at the C-terminus of all constructs to facilitate protein detection and purification.

### Transient Expression in Plants

The expression constructs described above were introduced into *Agrobacterium tumefaciens* strain GV3101 by electroporation (25 µF, 2.5 kV, 200 Ω), using a Multiporator system (Eppendorf, Germany). Recombinant agrobacteria were identified by PCR

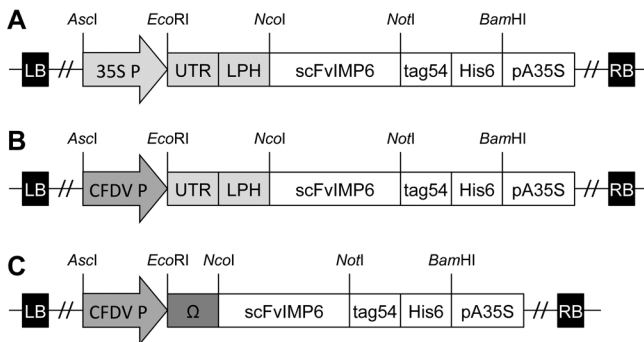

**Fig. 1.** Schematic presentation of the pTRAKT constructs used for scFvIMP6 expression in plants, with the restriction sites shown. (A) pTRA-35S-LPH:scFvIMP6 containing the CaMV35S promoter and the LPH targeting signal sequence for constitutive expression in the apoplast. (B) pTRA-CFDV-LPH:scFvIMP6 containing the CFDV promoter and the LPH targeting signal sequence for phloem-specific expression in the apoplast. (C) pTRA-CFDV-Ω:scFvIMP6 containing the CFDV promoter for phloem-specific expression in the cytosol. 35SP: *Cauliflower mosaic virus* 35S promoter; CFDV P: phloem-specific *Coconut foliar decay virus* promoter; UTR: 5' untranslated region from *Petroselinum hortense* chalcone synthase gene; Ω leader: TMV 5' untranslated region; LPH: targeting signal sequence from the murine mAb24 heavy chain [32]; pA35: *Cauliflower mosaic virus* 35S polyadenylation signal; tag54 and His<sub>6</sub>: detection and purification tags. Not drawn to scale.

using primers pSS5 (5'-ATC CTT CGC AAG ACC CTT CCT CT-3') and pSS3' (5'-AGA GAG AGA TAG ATT TGT AGA GA-3') under the following conditions: initial denaturation at 94°C for 10 min, followed by 25 cycles of denaturing at 94°C for 30 sec, annealing at 55°C for 30 sec, and extension at 72°C for 2 min, and a final extension at 72°C for 10 min.

Positive clones were transferred to YEB medium and cultivated for 48 h at 28°C with shaking at 160 rpm. Each culture was diluted with 2× infiltration medium (20 g/l sucrose, 1 g/l Fertyl 2 mega, 4 g/l glucose; pH 5.6) to an optical density (OD<sub>600</sub>) of 1.0 and supplemented with 200 mM acetosyringone. Recombinant bacteria expressing the p19 silencing suppressor [9] were added to the suspension, which was incubated at room temperature for 2–3 h before infiltration. Recombinant protein accumulation was evaluated by transient expression assay. The first fully developed apical leaves of *N. benthamiana* plants were agroinfiltrated using a 1 ml syringe without a needle. The leaves were superficially wounded with a needle to improve infiltration. The plants were then maintained at 25°C with a 16 h photoperiod for 4 days.

#### Protein Extraction, Purification, and Functional Analysis

Plant leaves were ground to a fine powder under liquid nitrogen and extracted in two volumes of phosphate-buffered saline (PBS; pH 8.0) containing 10 mM sodium disulfide and a protease inhibitor cocktail (complete ULTRA Tablets; Roche, Germany). The extract was centrifuged at 40,000 ×g for 10 min at 4°C, supplemented with NaCl to a final concentration of 500 mM, adjusted to pH 8.0, and

placed on ice for 30 min. The sample was centrifuged as above and the supernatant was filter-sterilized (0.45 μm) and stored on ice. Affinity chromatography was carried out using nickel-iminodiacetic acid resin (Macherey-Nagel, Germany). The integrity and purity of the isolated proteins were determined by sodium dodecyl sulfate polyacrylamide gel electrophoresis (SDS-PAGE) and immunoblotting, as previously described [34]. The partially purified scFvs were quantified by immunoblotting using AIDA software and known concentrations of a plant-produced and affinity-purified scFv as a standard.

#### Enzyme-Linked Immunosorbent Assay (ELISA)

Binding between the bacteria-produced scFv and intact phytoplasma cells was determined by indirect ELISA [17]. Maxisorp 96-well microtiter plates (Nunc-Immuno, Denmark) were coated with an anti-IMP polyclonal antibody diluted 1:500 in PBS, and incubated at 37°C for 2 h [28]. Extracts from healthy and infected lime plants, or purified recombinant IMP, were added to the plate and incubated overnight at 4°C. We then added 100 μl of the scFv preparation, and binding was detected using 0.5 μg/ml of the primary mouse anti-Myc monoclonal antibody 9E10 (Abcam, USA) and a secondary goat-anti mouse IgG alkaline phosphatase conjugate (0.16 μg/ml). ELISA readings (OD<sub>405</sub>) were taken after a 30 min incubation with para-nitrophenyl phosphate (pNPP) at 37°C.

The binding of the plant-produced and affinity-purified scFv to the recombinant IMP was determined by testing serial concentrations of purified scFvs (30–0.03 μg/ml) by indirect ELISA, using the primary mouse monoclonal antibody 54 (mAb54) recognizing the tag54 epitope (1:1,000) [19] and a goat-anti mouse IgG horseradish peroxidase conjugate (1:5,000, 0.8 mg/ml) (Jackson Immuno Research Laboratories), followed by signal detection using 2,2'-azino-bis (3-ethylbenzothiazoline-6-sulfonic acid) substrate (ABTS).

#### Immunoblot Analysis

Purified scFvs from *N. benthamiana* leaves were separated by SDS-PAGE and transferred to a 0.45 μm nitrocellulose membrane. This was blocked with 3% (w/v) skimmed milk powder in PBS, and the immobilized proteins were detected with anti-mAb54 (1:1,000) and a secondary goat-anti mouse IgG alkaline phosphatase conjugate (1:5,000, 0.6 mg/ml) (Jackson Immuno Research Laboratories), followed by staining with nitroblue tetrazolium/5-bromo-4-chloro-3-indolyl phosphate (NBT/BCIP; Bio-Rad). IMP produced in bacteria was detected using specific scFvs also produced in bacteria, and the bound scFvs were detected using monoclonal antibody mAb54 and a secondary goat-anti mouse IgG alkaline phosphatase conjugate, followed by staining with NBT/BCIP.

## Results

#### Selection of IMP-Specific scFv Antibodies

Phytoplasma-specific scFv antibodies were isolated from the human single-fold scFv libraries Tomlinson I + J

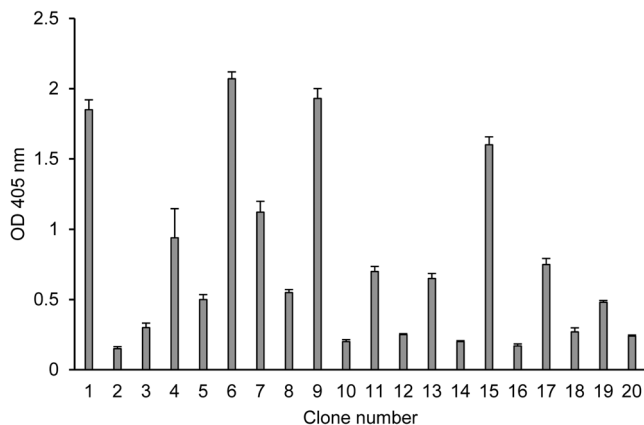

**Fig. 2.** Binding of scFv antibodies, determined by indirect ELISA against recombinant IMP.

Recombinant IMP (10 µg/ml) was directly coated onto the microtiter plates. Each bacteria-produced scFv was detected using the Myc-specific primary antibody 9E10 and a secondary goat anti-mouse polyclonal antibody conjugated to horseradish peroxidase. ELISA readings ( $OD_{405}$ ) were collected after a 30 min incubation with ABTS substrate at 37°C. Error bars represent the mean  $\pm$  standard deviations of two biological replicates.

(Source Bioscience, UK) by screening with recombinant IMP, which had been produced in bacteria and purified by immobilized metal-ion affinity chromatography (IMAC) *via* the His<sub>6</sub> tag. We carried out three rounds of panning with 10<sup>13</sup> recombinant phage, resulting in a 10-fold enrichment of scFv-displaying phages per round. After each round, the integrity of full-size scFv fragments was verified by PCR amplification using vector-specific primers, followed by *Bst*NI fingerprinting to visualize the diversity of the library (data not shown). After the third round, 96 individual bacterial colonies were randomly selected and their ability to produce soluble scFv was determined by dot blotting. We found that approximately 50% of the clones selected from the Tomlinson I library produced detectable scFvs, and these were screened for IMP binders by indirect ELISA. We identified six individual clones (scFvIMP1, 4, 6, 7, 9, and 15) producing IMP-specific scFvs that did not bind to the negative control, bovine serum albumin (BSA; Fig. 2). The presence of the full-size fragments and the diversity of the positive clones were evaluated by PCR and *Bst*NI fingerprinting, which showed that all clones contained ~1 kb inserts with a single band pattern (data not shown).

### Sequencing the Selected scFv Genes

DNA from five of the selected scFv clones produced strong and specific signals in ELISA (Fig. 2, scFvIMP1, 6, 7,

9, and 15) and these were sequenced using primers specific for the pHEN vector. This revealed the presence of two unique scFvs, scFvIMP6 and scFvIMP7, with minor differences in the complementarity-determining regions (Fig. 3). Alignment with sequences from the IMGT database ([http://imgt.cines.fr/IMGT\\_vquest](http://imgt.cines.fr/IMGT_vquest)) showed that the VH domains could be assigned to subgroup IGHV3 and the VL domains could be assigned to subgroup IGKV1.

### Characterization of the Selected scFvIMPs

Immunoblot analysis confirmed the specific binding of scFvIMP6 against the affinity-purified 19 kDa recombinant IMP (Fig. 4). The upper band detected in the immunoblot obviously indicated binding to the IMP dimer. The scFvIMP7 showed similar bindings patterns to the recombinant IMP in the immunoblot analysis (data not shown).

We further studied if the IMP-specific scFvs were able to bind to the phytoplasma-infected plant material by indirect ELISA. As shown in Fig. 5, there was a 3- to 4-fold higher binding of the scFvIMP6 to the recombinant IMP and to the phytoplasma-infected plant material, compared with healthy plant. The scFvIMP7 had a lower reactivity to the intact phytoplasma than scFvIMP6. Taken together, these results confirm that the selected scFvs are able to bind phytoplasma cells in infected plants and not to background material coming from the plant.

### Transient Expression of Functional scFvs in *N. benthamiana*

The scFvIMP6 was selected for transient expression in *N. benthamiana* plants because of its higher IMP-binding affinity, and so we designed a series of expression cassettes directing the recombinant protein to accumulate in the cytosol (pTRA-CFDV-Ω:scFvIMP6) or apoplast (pTRA-35S-LPH:scFvIMP6 and pTRA-CFDV-LPH:scFvIMP6). The CaMV35S promoter was used for constitutive expression (pTRA-35S-LPH:scFvIMP6) and the CFDV promoter was used for phloem-specific expression (pTRA-CFDV-LPH:scFvIMP6 and pTRA-CFDV-Ω:scFvIMP6).

The leaves were removed 4 days after agroinfiltration, total soluble proteins were extracted, and the recombinant antibody fragments were partially purified by IMAC. The proteins were analyzed by SDS-PAGE, followed by staining with Coomassie brilliant blue (data not shown) and immunoblotting, revealing a single band with the anticipated size of 32 kDa (Fig. 6). Comparative analysis showed varying amounts of non-purified and partially purified protein accessed from different expression states. The amount of partially purified scFvs was determined by immunoblot analysis using a control scFv of known concentration, indicating

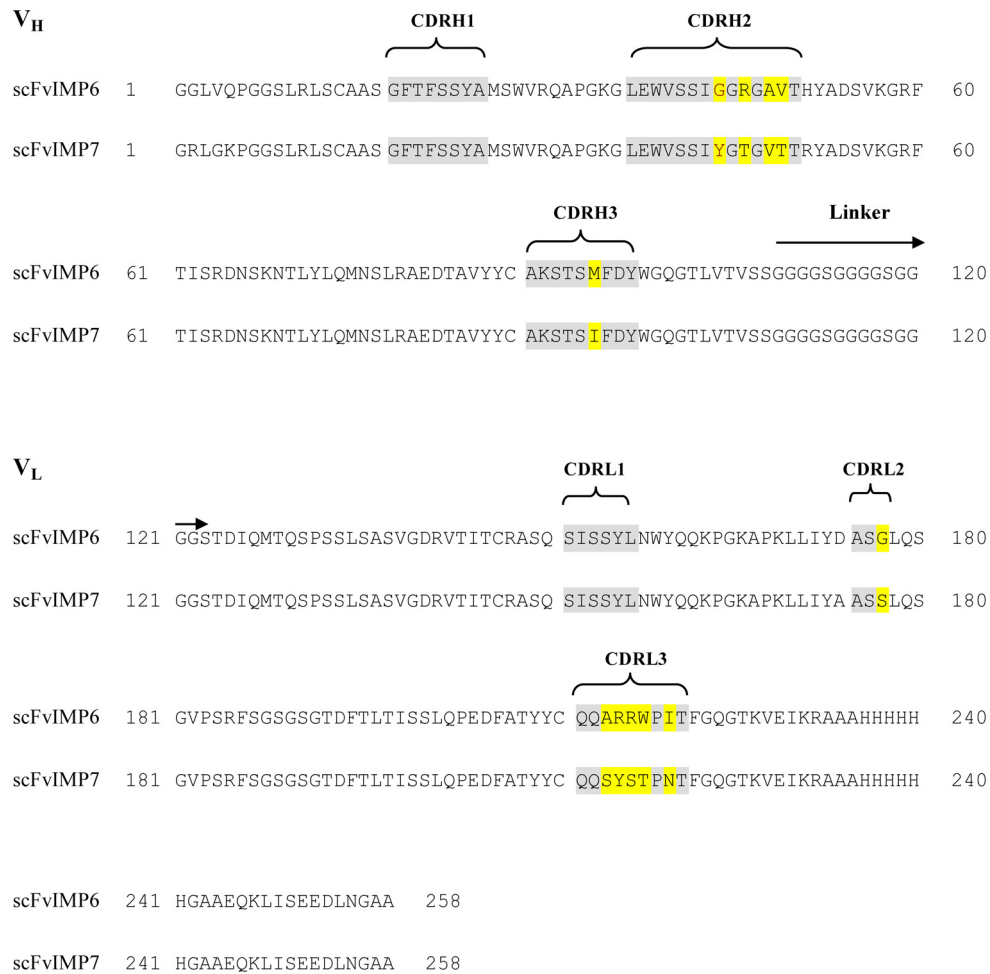

**Fig. 3.** Multiple amino acid sequence alignments of IMP-specific scFvIMP6 and scFvIMP7, isolated from the Tomlinson I phage display library.

The complementarity-determining regions (CDRs) of the variable domains are indicated in gray, and dissimilar residues are highlighted in yellow. The V<sub>H</sub> and V<sub>L</sub> fragments are linked with a (G<sub>4</sub>S)<sub>3</sub> linker.

that by applying constitutive apoplast-targeted expression, the highest yields of at least 40–50 µg/g fresh weight were achieved. Phloem-specific cytosolic expression achieved yields of ~26 µg/g fresh weight, and phloem-specific apoplast targeting achieved the lowest yields of 10 µg/g fresh weight.

#### Functionality of scFvs Extracted from Plants

The binding of plant-produced and affinity-purified scFvIMP6 was evaluated by indirect ELISA using high-binding microtiter plates coated with recombinant IMP produced in bacteria (Fig. 7). We applied several different concentrations of the antibody (30–0.03 µg/ml), and this showed that plant-produced scFvIMP6 binds strongly to recombinant IMP, confirming that it folds correctly and is

functionally in both the cytosol and the apoplast of plant cells regardless of whether a constitutive or phloem-specific promoter is used for expression.

## Discussion

Recombinant antibodies expressed in plants can confer resistance against several plant pathogens [10, 15, 18, 23, 25, 30, 33]. The scFv is the smallest immunologically active molecule that can replicate the binding specificity of parental monoclonal antibody, and such antibody fragments can be directed to accumulate in any compartment of the plant cell [5].

We selected two scFvs (scFvIMP6 and scFvIMP7) from naïve phage display libraries by exploiting their high

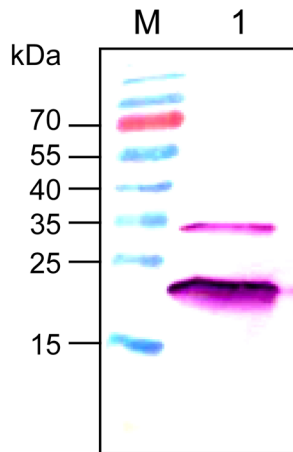

**Fig. 4.** Immunoblot analysis of scFvIMP6 against recombinant IMP.

The bacteria-produced and affinity-purified recombinant IMP was blotted onto a nitrocellulose membrane and detected using scFvs (~1 µg/ml) derived from bacteria, which were in turn detected using monoclonal antibody 9E10 and goat anti-mouse antibody conjugated to alkaline phosphatase, followed by staining with NBT/BCIP. M: protein marker; lane 1: IMP.

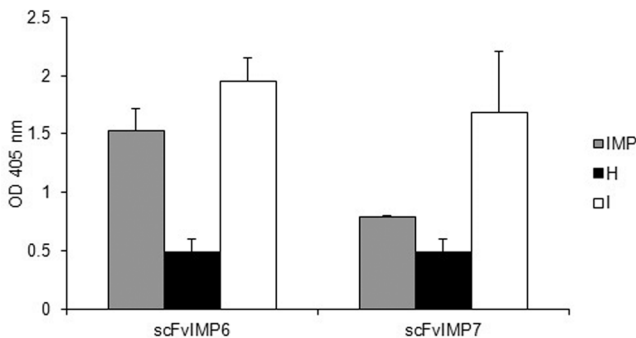

**Fig. 5.** The use of bacteria-produced scFvs to detect infected plants by ELISA.

Recombinant IMP (10 µg/ml) was captured by anti-IMP polyclonal antibodies, which were directly coated onto the microtiter plates. Bound scFvs were detected using the anti-Myc monoclonal antibody 9E10 and goat anti-mouse polyclonal antibody alkaline phosphatase conjugate followed by the addition of pNPP substrate. I: infected sample; H: healthy lime plant; IMP: recombinant IMP. Each value represents the mean of three replicates. Error bars represent the mean ± standard deviations of three biological replicates.

affinity for recombinant IMP. Because scFvIMP6 had a higher affinity than scFvIMP7, the scFvIMP6 cDNA was transiently expressed in *N. benthamiana* leaves using constructs designed for constitutive or phloem-specific expression and for accumulation in the cytosol or apoplast. Successful

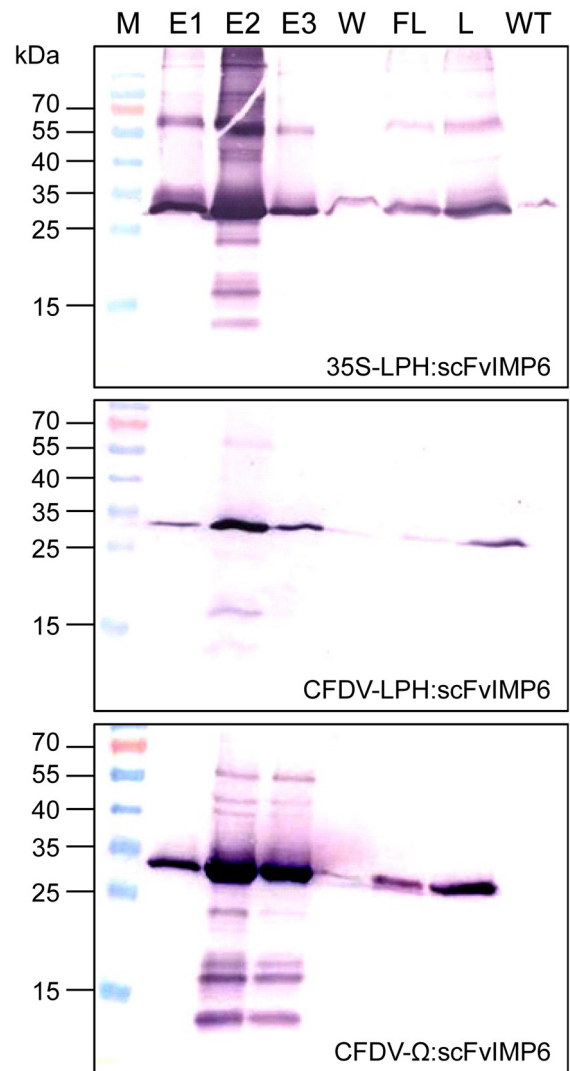

**Fig. 6.** Immunoblot analysis of scFvIMP6 transiently produced in *N. benthamiana* and purified by IMAC.

The constructs used for expression are indicated. The scFvs were detected using the primary murine mAb54 and goat anti-mouse secondary antibody alkaline phosphatase conjugate. M: protein marker; E: elution fractions; W: washing; FL: flow fraction; L: load (plant extract containing total soluble proteins); WT: wild-type extract control.

expression was achieved with all three constructs, such that scFvIMP6 accumulated at detectable levels in both the cytosol and the apoplast, regardless of which promoter was used (Fig. 6). We found that scFvIMP6 accumulated to high levels in the reducing environment of the cytosol under the control of the phloem-specific CFDV promoter, as previously reported for a scFv recognizing the coat protein of *Grapevine leafroll-associated virus 3* (GLRaV-3) [17]. Generally, scFvs are unstable and nonfunctional without disulfide bridges

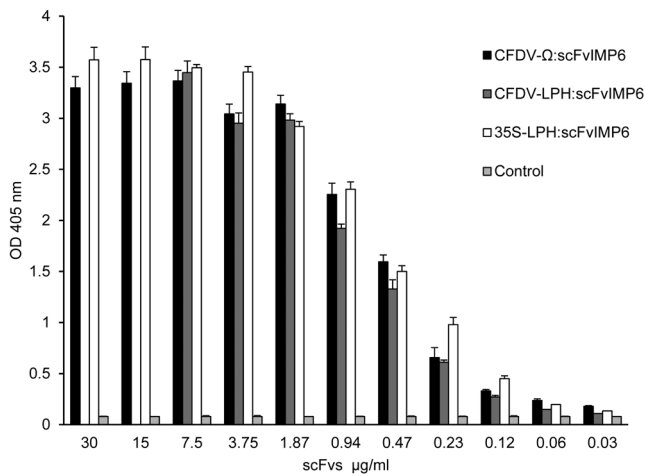

**Fig. 7.** Binding of cytosolic and apoplast scFvIMP6 transiently expressed in *N. benthamiana* to recombinant IMP, as determined by ELISA.

Cytosolic and apoplast scFvIMP6 was transiently expressed in *N. benthamiana* leaves under the control of the CaMV 35S or CFDV promoters. Purified scFvIMP6 was serially diluted in PBS and added to a microtiter plate coated with recombinant IMP. Bound scFv fragments were detected with mAb54 and a polyclonal goat anti-mouse antibody horseradish peroxidase conjugate, followed by ABTS substrate. Error bars represent the mean  $\pm$  standard deviations of two biological replicates.

[6]. Nevertheless, some antibody scaffolds can tolerate the absence of disulfide bridges and maintain their stability and functionality, even in a reducing environment such as the cytosol [16, 30].

We compared the expression of scFvIMP6 using the constitutive CaMV 35S promoter and the phloem-specific CFDV promoter, finding that the constitutive promoter was more efficient. However, the lower yields achieved with the phloem-specific promoter may still be sufficient to induce phytoplasma resistance in transgenic plants, because the pathogen accumulates specifically in this tissue and it may be beneficial to concentrate the antibody therein [11].

A comparative study of cytosolic and apoplast accumulation has also been carried out with an anti-stolbur phytoplasma scFv expressed in transgenic tobacco shoots that were grafted onto infected rootstock in the greenhouse and field. The scFv accumulated to high levels when secreted to the apoplast and delayed the onset of disease symptoms by approximately 2 weeks, also reducing the severity of the disease. However, cytosolic expression of scFv led to no detectable amount of protein and the transgenic plants did not show any resistance to the disease [12].

The accumulation of functional scFvIMP6 in the cytosol and apoplast of infiltrated *N. benthamiana* plants and the ability of purified scFvIMP6 to detect recombinant IMP provided further evidence for correct protein folding and confirmed that the antibody binds its cognate antigen with high affinity. The only previous report of a recombinant antibody generated against phytoplasma used hybridoma technology [10]; therefore, we are the first to report the use of scFv phage display libraries for this purpose. The selective pressure applied during the panning of phage display libraries favors the selection of more soluble recombinant antibodies, and the functionality and stability observed during transient expression in plants suggests that scFvIMP6 is a suitable candidate for stable expression in transgenic plants for the suppression of witches' broom of lime.

## References

- Bird RE, Hardman KD, Jacobson JW, Johnson S, Kaufman BM, Lee SM, *et al.* 1988. Single chain antigen-binding proteins. *Science* **242**: 423-426.
- Bove JM. 1986. Witches' broom disease of lime. *FAO Plant Prot. Bull.* **34**: 217-218.
- Chung KR, Khan IA, Brlansky RH. 2006. Citrus diseases exotic to Florida: Witches' Broom Disease of Lime (WBDL). *Fact Sheet*, PP-228. UF/IFAS EDIS (Electronic Data Information Systems) Database.
- Clackson T, Hoogenboom HR, Griffiths AD, Winter G. 1991. Making antibody fragments using phage display libraries. *Nature* **352**: 624-628
- Firek S, Draper J, Owen M, Ganfecha A, Cockburn B, Whitelam G. 1993. Secretion of a functional single-chain Fv protein in transgenic tobacco plants and cell suspension cultures. *Plant Mol. Biol.* **23**: 861-870.
- Glockshuber R, Schmidt T, Pluckthun A. 1992. The disulfide bonds in antibody variable domains effects on stability, folding *in vitro*, and functional expression in *Escherichia coli*. *Biochemistry* **31**: 1270-1279.
- Hogenhout SA, Oshima K, Ammar ELD, Kakizawa S, Kingdom HN, Namba S. 2008. Phytoplasmas: Bacteria that manipulate plants and insects. *Mol. Plant Pathol.* **9**: 403-423.
- Konz C, Schell J. 1986. The promoter of TL-DNA gene 5 controls the tissue-specific expression of chimaeric genes carried by a novel type of *Agrobacterium* binary vector. *Mol. Gen. Genet.* **204**: 382-396.
- Lakatos L, Szittyta G, Silhavy D, Burgyan J. 2004. Molecular mechanism of RNA silencing suppression mediated by p19 protein of tombusviruses. *EMBO J.* **23**: 876-884.
- Le Gall F, Bove JM, Garnier M. 1998. Engineering of a single-chain variable-fragment (scFv) antibody specific for the stolbur phytoplasma (Mollicute) and its expression in

- Escherichia coli* and tobacco plants. *Appl. Environ. Microbiol.* **64**: 4566-4572.
11. Lepka P, Stitt M, Moll E, Seemüller E. 1999. Effect of phytoplasmal infection on concentration and translocation of carbohydrates and amino acids in periwinkle and tobacco. *Physiol. Mol. Plant Pathol.* **55**: 59-68.
  12. Malembic-Maher S, Le Gall F, Danet JL, Borne FD, Bove JM, Garnier-Semancik M. 2005. Transformation of tobacco plants for single-chain antibody expression *via* apoplastic and symplasmic routes, and analysis of their susceptibility to stolbur phytoplasma infection. *Plant Sci.* **168**: 349-358.
  13. Mardi M, KhayamNekouei SM, KarimiFarsad L, Ehya F, Shabani M, Shafiee M, et al. 2011. Witches' broom disease of Mexican lime trees: Disaster to be addressed before it will be too late. *Bull. Insectology* **64(Supplement)**: S205-S206.
  14. Milne RG, Ramasso E, Lenzi R, Masenga V, Sarindu N, Clark MF. 1995. Pre- and post-embedding immunogold labeling and electron microscopy in plant host tissues of 3 intigenically unrelated MLOs Primula yellows, tomato big bud and bermudagrass white leaf. *Eur. J. Plant Pathol.* **101**: 57-67.
  15. Nölke G, Cobanov P, Uhde-Holzem K, Reustle G, Fischer R, Schillberg S. 2009. *Grapevine fanleaf virus* (GFLV)-specific antibodies confer GFLV and *Arabidopsis mosaic virus* (ArMV) resistance in *Nicotiana benthamiana*. *Mol. Plant Pathol.* **10**: 41-49.
  16. Nölke G, Schneider B, Fischer R, Schillberg S. 2005. Immunomodulation of polyamine biosynthesis in tobacco plants has a significant impact on polyamine levels and generates a dwarf phenotype. *Plant Biotechnol. J.* **3**: 237-247.
  17. Orecchia M, Nölke G, Saldarelli P, Dell'Orco M, Uhde-Holzem K, Sack M, et al. 2008. Generation and characterization of a recombinant antibody fragment that binds to the coat protein of *Grapevine leafroll-associated virus 3*. *Arch. Virol.* **153**: 1075-1084.
  18. Prins M, Lohuis D, Schots A, Goldbach R. 2005. Phage display-selected single-chain antibodies confer high levels of resistance against *Tomato spotted wilt virus*. *J. Gen. Virol.* **86**: 2107-2113.
  19. Rasche S, Martin A, Holzem A, Fischer R, Schinkel H, Schillberg S. 2011. One-step protein purification use of a novel epitope tag for highly efficient detection and purification of recombinant proteins. *Open Biotechnol. J.* **511**: 1-6.
  20. Rohde W, Becker D, Randles JW. 1995. The promoter of coconut foliar decay-associated circular single-stranded DNA directs phloem-specific reporter gene expression in transgenic tobacco. *Plant Mol. Biol.* **27**: 623-628.
  21. Sack M, Paetz A, Kunert R, Bomble M, Hesse F, Stiegler G, et al. 2007. Functional analysis of the broadly neutralizing human anti-HIV-1 antibody 2F5 produced in transgenic BY-2 suspension cultures. *FASEB J.* **21**: 1655-1664.
  22. Safarnejad MR, Fischer R, Commandeur U. 2008. Generation and characterization of functional recombinant antibody fragments against *Tomato yellow leaf curl virus* replication-associated protein. *Commun. Agric. Appl. Biol. Sci.* **73**: 311-321.
  23. Safarnejad MR, Fischer R, Commandeur U. 2009. Recombinant-antibody-mediated resistance against *Tomato yellow leaf curl virus* in *Nicotiana benthamiana*. *Arch. Virol.* **154**: 457-467.
  24. Safarnejad MR, SalehiJouzani GR, Tabatabaie M, Twyman RM, Schillberg S. 2011. Antibody-mediated resistance against plant pathogens. *Biotechnol. Adv.* **29**: 961-971.
  25. Schillberg S, Zimmermann S, Findlay K, Fischer R. 2001. Plasma membrane display of anti-viral single chain Fv fragments confers resistance to *Tobacco mosaic virus*. *Mol. Breed.* **6**: 317-326.
  26. Shabani M, Mardi M, Sarafrazi A, Naraghi SM, Rahimian H, Shojaee M. 2011. Isolation and characterization of novel microsatellite marker from the leafhopper *Hishimonus phycitis* Distant. (Hemiptera: Cicadellidae). *Conserv. Genet. Resour.* **3**: 493-495.
  27. Shahryari F, Safarnejad MR, Shams-bakhsh M. 2011. Generation of a specific monoclonal recombinant antibody against '*Candidatus* phytoplasma aurantifolia' using phage display technology. *Bull. Insectol.* **64**: S75-S76.
  28. Shahryari F, Shams-Bakhsh M, Safarnejad MR, Safaie N, Ataei Kachoeie S. 2013. Preparation of antibody against immunodominant membrane protein (IMP) of *Candidatus* Phytoplasma aurantifolia. *Iran. J. Biotech.* **11**: 34-41.
  29. Shahryari F, Safarnejad MR, Shams-Bakhsh M, Salehi-Jouzani GR. 2010. Toward immunomodulation of witches broom disease of lime (WBDL) by targeting immunodominant membrane protein (IMP) of *Candidatus* Phytoplasma aurantifolia. *Commun. Agric. Appl. Biol. Sci.* **75**: 789-795.
  30. Tavladoraki P, Girotti A, Donini M, Arias FJ, Mancini C, Morea V, et al. 1999. A single-chain antibody fragment is functionally expressed in the cytoplasm of both *Escherichia coli* and transgenic plants. *Eur. J. Biochem.* **262**: 617-624.
  31. Weisburg WG, Tully JG, Rose DL, Petze JP, Oyazu H, Yan D, et al. 1989. A phylogenetic analysis of the mycoplasmas: Basis for their classification. *J. Bacteriol.* **171**: 6455-6467.
  32. Voss A, Niersbach M, Hain R, Hirsch H, Liao YC, Kreuzaler F, et al. 1995. Reduced virus infectivity in *N. tabacum* secreting a TMV-specific full-size antibody. *Mol. Breed.* **1**: 39-50.
  33. Yajima W, Verma SS, Shah S, Rahman MH, Liang Y, Kav NN. 2010. Expression of anti-sclerotinia scFv in transgenic *Brassica napus* enhances tolerance against stem rot. *N. Biotechnol.* **27**: 816-821.
  34. Zimmermann S, Schillberg S, Liao YC, Fischer R. 1998. Intracellular expression of TMV-specific single-chain Fv fragments leads to improved virus resistance in *Nicotiana tabacum*. *Mol. Breed.* **4**: 369-379.