

Study on EMTP Simulation Applying Dual Reactor for Prevention of the Ferro-resonance and VT Burnout in Substation System

Seok-kon Kim†, Yong-ho An, Byung-tae Jang, Jong-kee Choi, Nam-ho Lee, Jung-yeol Han, You-jin Lee

KEPCO Research institute, Korea Electric Power Corporation, 105 Munji-Ro, Yuseong-Gu, Daejeon 34056, Korea

† blade@kepco.co.kr

Abstract

When the line and switchgear of the substation system are disconnected, ferro-resonance can occur. This happens even if the capacitive reactance and inductive reactance are not equal, which are not common resonance conditions. Resonance conditions vary depending on the busbar configuration environment. Although the damping resistance method applying the existing saturable reactor to cope with ferro-resonance has been successfully applied on site, there can be loss of normal function during long-term operation. The reason is because the rise in the operating frequency of saturable reactors means the saturation number is increased. Therefore, it can no longer function as saturable reactor since the resistor having inadequate capacity is burned out. To address this problem, in this paper, an EMTP-based simulation test was performed by designing and applying a dual reactor method, which adds an extended divergence reactor to the 1st side of the VT. The test result confirms that when the divergence reactor is inserted, the voltage and current values obtained at the 1st side and 2nd side of the VT as well as current values of divergence reactor part were stabilized from the transient phenomena and return to normal values. When compared with existing measures, although this method is similar in adding having a reactor added to a system regarding ferro-resonance, it has the advantage of being able to prevent ferro-resonance in advance since the reactor is added before the system is saturated. In addition, because it does not use damping resistance, it can extend the equipment life and stabilize its operation. Therefore, there are a lot of differences in terms of its operating characteristics and achievement of goal between the conventional method and new divergence reactor method.

Keywords: Ferro-resonance, Saturable Reactor, Damping Resistance, Voltage Transformer, Dual Reactor

I. INTRODUCTION

A. Ferro-resonance Phenomenon in Substation System

Ferro-resonance phenomenon occurs primarily in substation facilities due to reactance changes in substation system such as opening and closing of breakers and line disconnection. It is a non-linear continuous oscillation phenomenon appearing between the inductances with saturation characteristics, which are connected in series with a capacitor in a circuit in which Sine wave AC power is applied. Therefore, it affects not only T/L (Transmission Line) and D/L (Distribution Line) divergence transformers of substations adopting GIS (Gas Insulated Switchgear) but also the operation of the substation facilities such as PT (Potential Transformer) of a busbar.

In order to reduce TRV (Transient Recovery Voltage), a circuit breaker over 50 kA is mounted to a grading capacitor having constant capacitance between the poles, and a compact wound-type PT is installed in the busbar to sense voltage from the busbar. In addition, there exists capacitance in the space between the busbar and earth due to by the insulation gap of GIS. At the time when opening the CB (Circuit Breaker) on T/L side or busbar Tie CB, the VT (Voltage Transformer) is saturated by LC resonance. Since overcurrent and PT coil burnout occur after this, these causes power outages and equipment failures.

Recently, CB has been produced with grading capacitors being removed to reduce TRV. However, in spite of removing grading capacitors, the resonance cannot be prevented in any case due to the nature of the busbar. To avoid ferro-resonance area, an effective method is to design a circuit in the way that capacitance

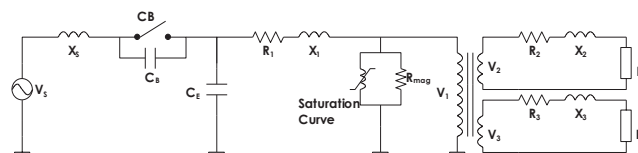

Fig. 1. Equivalent circuit configuration of busbar ferro-resonance generation

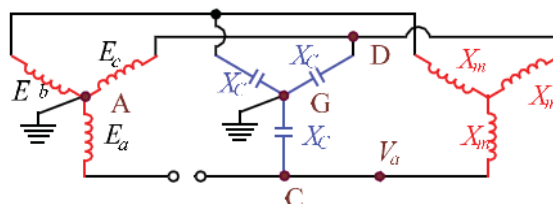

Fig. 2. Three-phase system single-line configuration

is increased in typical busbar on site [1].

Therefore, since increased value of C means reduction of capacitive reactance, it is necessary to relatively reduce capacitive reactance to effectively prevent resonance. In addition, other measures can be taken by relatively increasing the inductive reactance.

B. Other Resonance Environment on Substation System

It is necessary to note that ferro-resonance of busbar occurs not only when capacitive reactance and inductive reactance have the same resonance conditions but also when resonance

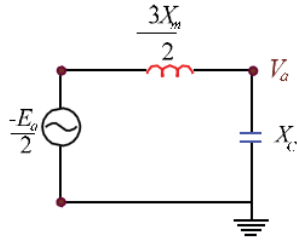

Fig. 3. A phase voltage reference equivalent circuit

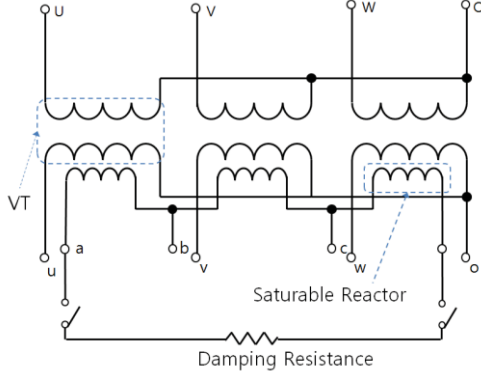

Fig. 4. Application structure of saturable reactor and Damping resistance

conditions are not zero (that is, the value of reactance is not zero). If the CB is operated or if one line of three-phase, power supply is disconnected as shown in Fig. 2, the equivalent circuit becomes as shown in Fig. 3.

In Fig. 3, the value of V_a regarding the equivalent circuit for A-phase potential can be represented with the formula below.

$$V_a = \frac{X_c/X_m}{3-2(X_c/X_m)} E_a$$

In the above formula, if the condition of $\frac{X_c}{X_m} = \frac{3}{2}$ becomes it represents a condition in which the resonance can occur. Therefore, if the capacitive reactance value becomes 1.5 times of the inductive reactance value of transformers by reducing the capacitance value relative to the inductance, the resonance occurs; thus, it is necessary to take precaution in this aspect [2]. As a result, a safe way to prevent resonance through improvement of the circuit can be achieved by either increasing capacitance or relatively increasing inductive reactance within the appropriate limit compared to capacitive reactance.

C. Existing Application Technologies to cope with Ferro-resonance

To prevent accidents in case resonance occurs in VT equipment on site, existing methods rely on suppressing constant saturation by inducing core-loss (current) in the resistance section. This is done by additionally installing resistors in series after installing reactor, which has less saturation characteristics than that of VT being located the latter part of 2nd VT circuit, before rapid saturation occurs when VT become close to non-linear saturation [3]. In other words, the saturable reactor causes ferro-resonance to be stopped. By changing the reactance value while inducing loss through damping resistance, the current

is induced to flow due to self saturation right after the system line and VT are saturated.

The saturable reactor as such not only performs the switching function which closes or opens current flowing through the resistance circuit but also utilizes the damping resistance method that induces resistor unit to flow current by enabling closing function during saturation.

D. Technical problems of Existing Ferro-resonance Suppression Methods.

The existing ferro-resonance suppression technologies using saturable reactor and damping resistance have the following problems:

First, when the number of saturations within the system increases, it loses the function of saturable reactor and damping resistance; thus, it cannot prevent system resonance. Too low damping resistance can provoke over-current [4]. Therefore, when saturable lose its inherency over-current can cause a damage of resistance in reverse.

Conventional damping resistance methods can be operated safely during the initial period when of the operation of saturable reactor is not much. However, if the saturable reactor inserted to control damping function is getting close to the resonant environment on the busbar or when magnetic flux or current of VT 1st side increase abnormally, it may become saturated earlier than reactor of 1st side and play a role of a switch that turns on and off the current flowing into resistive elements. When the number of such saturation increases, the reactor loses its unique characteristics. As a result, dielectric breakdown is caused by increased admittance. Also impedance of damping resistance arrive at a damage through a rapid decrease with occurrence of over-current and finally come out at open status [5]. At this time, the reactor loses the function of a normal saturated reactor

Second, the input voltage change in the voltage measuring module can cause the measurement value error as well as abnormal protection and control phenomenon. When the damping resistance is operating and the reactor is saturated in the 2nd side or 3rd side of VT, it causes the admittance value to rise due to temporary increase of VT load current value during saturation. In this case, it can adversely affect the normal function of protective relay units for system operation since the measurement values are changed when the measured voltage value is reduced. The changes in the reactance value caused by increased admittance value can degrade the reliability of the measurement value as a result of increased loss value if the short status between reactor coils continues.

When considering an example of a mathematical analysis that may result in malfunction and occurrence of loss due to loss of damping resistance function, no loss is observed in the 2nd side of VT during normal operation. However, when the damping resistance is operated, the loss can increase by hundreds of thousands times as the reactance value of reactor becomes closer to zero. Therefore, if the damping resistance has become burned out, the value cannot be ignored regarding the protection and control of the system from operational perspective. The operation method applying saturable reactor and damping resistance prevents the busbar unit of the VT 1st side from turning into full resonant state; however, since this structure operates after approaching close to the environment $X_e \cong X_l$ similar to resonance, it has a disadvantage of being an operating structure that does not fully prevent busbar resonance. Therefore, if the

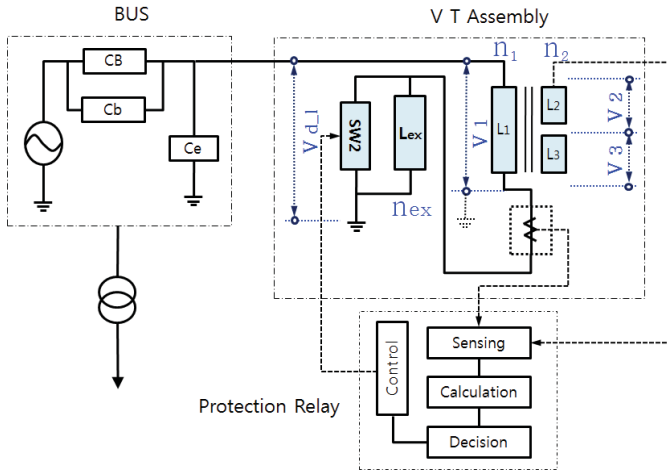

Fig. 5. Configuration of the extended divergence dual reactor system

saturable reactor loses normal function, the saturation of the 1st reactor can no longer be prevented when resonance occurs at the 1st side busbar. At this time, the generation of mis-information of low frequency with VT burnout may cause operation of UFR and lead to a power outage of the corresponding line.

II. SYSTEM DESIGN AND EXPERIMENT

The technical feasibility of this method will be investigated by performing an EMTP simulation and designing a circuit according to the operation method of dual reactors. Under the assumption that the existing ferro-resonance prevention technologies make stable mid to long term operation of the above introductory part difficult, a divergence reactor which is extended in series from conventional VT 1st side reactor is added in order to address this issue. However, with respect to the dual reactor operation approach described in this paper, it should be noted that although in real systems the divergence reactor is inserted prior to ferro-resonance generation, in this test, in order to directly confirm the effect of ferro-resonance removal, the divergence reactor is inserted after generating ferro-resonance and transient phenomenon was observed.

A. Application Test using an Extended Dual Divergence Reactor

The purposes of applying an extended divergence reactor which can continuously stabilize the reactance characteristics of VT 1st and 2nd side by early blocking substation facilities ferro-resonance which occurs at PT, TR etc. include the followings : 1. to fundamentally block (prevent) PT burnout which happens when ferro-resonance occurs. 2. to fundamentally block potential measurement errors which can be generated during the measurement of VT 2nd side, while taking conventional saturable reactor measures with damping resistance. 3. to find ways to fundamentally cut off saturation and failure possibilities occurring in the VT during ferro-resonance when the blocking switching function is lost due to saturable reactor burnout as a result of increased operation of damping resistance when applying damping resistance which utilizes saturable reactor, a conventional measure to address ferro-resonance.

As its attainment method, the conventional method will be used during normal operation. When approaching the high

likelihood of VT resonance in substation system, by recognizing this phenomenon in advance, we will use the dual reactor operation method in which an extended divergence reactor is added. Therefore, we can fundamentally preclude the possibility of resonance by increasing the inductive reactance.

B. Configuration of Dual Reactor Application System

The configuration of the system is as shown in Fig for the EMTP simulation of dual reactor application system to prevent ferro-resonance and VT burnout in the substation system. The addition of extended divergence reactor (L_{ex}) forms a dual reactor system and the ON/OFF of the divergence reactor is controlled in IED or protective relays which set the value of VT saturation characteristics. Meanwhile, the protective relay unit will continue to monitor the magnetic flux value of the VT by detecting the current of VT 1st side by the sensing unit.

Regarding the dual reactor application structure to prevent ferro-resonance in the substation system as shown in Fig. 5, the description of main parts and related symbols are as follows:

- n_1 : the number of windings at VT 1st side
- n_2 : the number of windings at VT 2nd side
- n_{ex} : the number of reactor lines for 1st side divergence
- V_1 : VT 1st side voltage
- V_2 : VT 2nd side voltage
- V_3 : VT 3rd side voltage
- V_{d-1} : Synthetic voltage of L_1 and L_{ex} when SW2 is opened.
- C_b : Grading Capacitance of CB between two plates
- C_e : Capacitance between Busbar (Bus) and Earth
- L_1 : VT 1st side reactor
- L_2 : VT 2nd side reactor
- L_3 : VT 3rd side reactor
- L_{ex} : 1st side extended divergence reactor
- V_s : Source Voltage
- V_{input} : protective relay measuring input voltage
- CB : Circuit Breaker
- SW2 : On/Off switch (MCCB, Solid State Relay)

Functions and operating methods of respective major equipment sectors relating to control method of extended divergence reactor (L_{ex}) for dual reactor operation will be described in detail in the following section.

C. Settings of VT inductance saturation point and reactor operating method

The manufacturer's supplied values or the experimental values of real systems can be used for inflection point-related magnetic flux value. It is a factor to determine time to introduce a divergence dual reactor in order to prevent the magnetic saturation of the VT during system operation.

The definitions of each symbol to define the inductance saturation point are as follows:

- Φ_{kp} (knee-point) : Magnetic flux in the saturation starting knee point
- Φ_{ukp} (upper knee-point) : Magnetic flux in the fully saturated region exceeding Φ_{kp}
- Φ_{bkp} (beneath knee-point) : Magnetic flux in area with linear characteristic just before reaching Φ_{kp}
- i_1 : Through-current value in the Φ_{bkp}

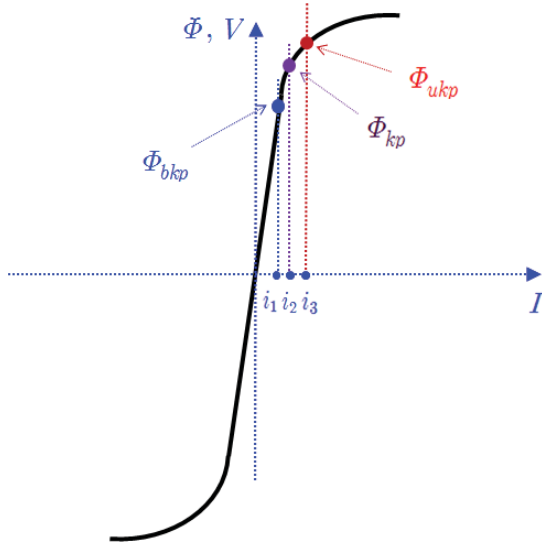

Fig. 6. Definition of saturation point in the Inductance Saturation curve

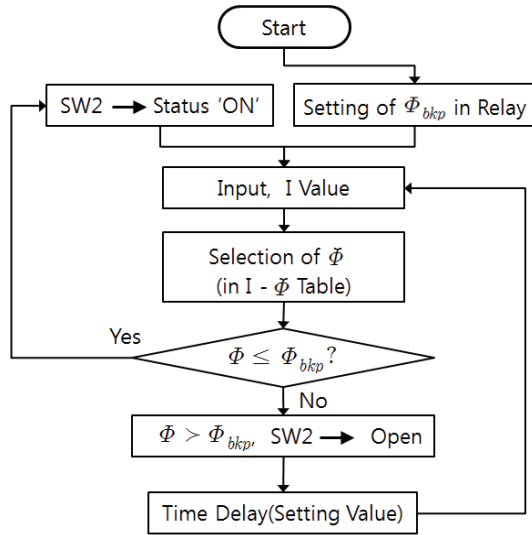

Fig. 7. Setting of Inductance saturation point & algorithm

i_2 : Through-current value in the Φ_{kp}
 i_3 : Through-current value in the Φ_{ukp}

The operating method of divergence reactor as per VT inductance saturation point shall be found out in advance by setting the inductance magnetic saturation characteristic value of the reactor for VT in the protective relay unit, including magnetic flux value (Φ_{bkp}) or its corresponding current value (i_1) in the linear characteristic area, immediately before an inflection point is reached as shown in Fig. 7. If i_1 value of the VT circuit reaches Φ_{bkp} during the actual operation of the system as shown in Fig. 8, the saturation point setting and judging method can be applied. This is to prevent VT from being saturated by introducing the extended divergence reactor by opening the SW2 (divergence reactor control switch).

It is necessary to perform opening (adding divergence reactor) and closing (removing divergence reactor) control of SW2 when the transient presence in the busbar system exceeds or falls below a threshold point of the linear area immediately before reaching an inflection point of magnetic saturation in which the

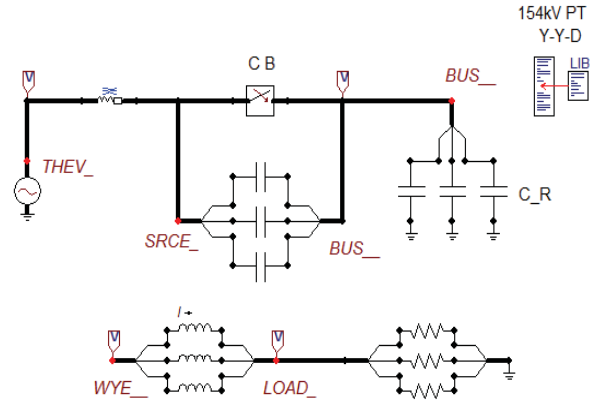

Fig. 8. EMTP/ATPDraw circuits for Ferro-resonance Simulation

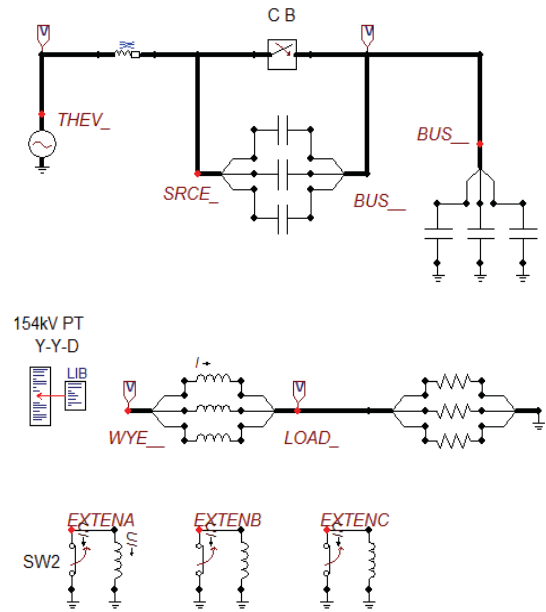

Fig. 9. EMTP / ATPDraw Circuit Diagrams for Divergence reactor method applying Dual reactor

magnetic flux saturation is started by detecting changes in the magnetic flux value in real time through the current measurement of VT.

When the extended divergence reactor is put into a circuit after the divergence control switch is opened, the divergence reactor is added to the 1st side reactor. Therefore, it is possible to operate by calibrating the voltage value in consideration of the expansion ratio of the number of lines (n_{ex}) of 1st side divergence reactor when calculating measurement values by sensing the voltage in the protective relay unit.

D. EMTP simulation circuit implementation

1) EMTP / ATPDraw circuit design for ferro-resonance simulation

Utilizing EMTP/ATPDraw tools, three kinds of simulations were carried out for ferro-resonance simulation test in substation system. First, in order to simulate the ferro-resonance state, the resonant reactance value was set up so that L and C values can resonate. The ferro-resonance simulation EMTP/ATPDraw

Table 1. Main value settings of EMTP simulation in Divergence reactor application method (DAT File)

```

C TRANSFORMER
C REQUESTWORD REF.BUS STEADY I, FLUX BUS R-MAG
  TRANSFORMER .0269 766.30 X 5.6E7
C TRANSFORMER .0007 195.96 X
C 1-16 17-32
C CURRENT FLUX
  5.14E-4 225.4
  2.01E-3 450.8
  6.85E-3 586.0
  1.47E-2 676.1
  0.02690 766.3
  3.67E-2 811.4
  5.14E-2 856.5
  6.12E-2 879.0
  7.83E-2 901.5
  7.83E-1 946.6
~
C CONNECTED ON PT WYE SECONDARY
C 242 ohms= 50 [VA] modeling
C BUS1 BUS2 BUS3 BUS4 OHM OHM UMHO V= 2
  WYE_ALOAD_A 242. 3
  WYE_BLOAD_BWYE_ALOAD_A 3
  WYE_CLOAD_CWYE_ALOAD_A 3
C BUS1 BUS2 BUS3 BUS4 OHM OHM UMHO V = 2
  LOAD_A 1.E-3
  LOAD_B 1.E-3
  LOAD_C 1.E-3
C WYE_ALOAD_A 40.
~
C SWITCH CARDS
C TIME TO TIME TO OR VOLTAGE REQUEST SWITCH-NAME
C BUS1 BUS2 CLOSE OPEN NSTEP WORD BUS5 BUS6
  SRCE_ABUS_A -1. .020 3
  SRCE_BBUS_B -1. .020 3
  SRCE_CBUS_C -1. .020 3
C LOAD_A .040 1.00
C LOAD_B .040 1.00
C LOAD_C .040 1.00
BLANK CARD TERMINATING SWITCH CARDS
C SOURCE CARDSS
C 3-8 11-20 21-30 31-40 41-50 51-60 61-70 71-80
C NODE AMPLITUDE FREQUENCY TO IN SEC AMPL-A1 TIME-T1 T-START T-STOP
C NAME IN HZ DEGR SECONDS SECONDS SECONDS
14THEV_A 125740. 60.0 0. -1.0
14THEV_B 125740. 60.0 240. -1.0
14THEV_C 125740. 60.0 120. -1.0
    
```

circuit diagrams are as shown in Fig. 8. Also, the main parameters and circuit value settings for ferro-resonance circuit configuration are the same as shown in the DAT file of Table 1 below. Other setting values were used a simulated value applying an approximation converting I-Φ characteristic curve to 154 kV substation environment [1][6].

2) EMTP / ATPDraw Circuit Design for Applying Extended Dual Reactor

The main research focus of this paper is to perform simulation to prevent burnout of VTs and ferro-resonance focusing on the PT of 154 kV Substation. By making the dual reactor operate, it was configured so that the resonance of the system can be prevented by introducing an extended divergence

reactor immediately before PT becomes saturated and resonance starts due to transients in the system. In addition, it was set up so that it can achieve non-resonant state by increasing the C value in ferro-resonance simulation circuit diagram of the above a) item to prevent L and C from resonating in order to simulate the normal (non-resonant) state.

This was compared with the simulation results when applying dual reactor method. The reactance value of the extended divergence reactor is set as 2.0~2.5 MΩ which is about 25% of 8~10 MΩ, the common 1st reactance value. The main parameter value settings of the dual reactor application method are as shown in DAT files of Table 1.

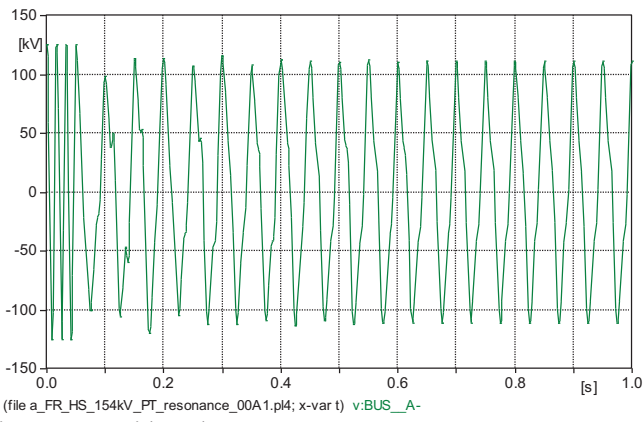

Fig. 10. 1st side voltage on Ferro-resonance state

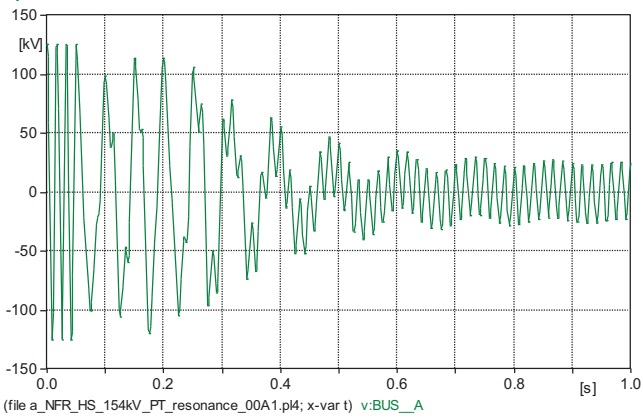

Fig. 11. 1st side voltage on Divergence reactor method

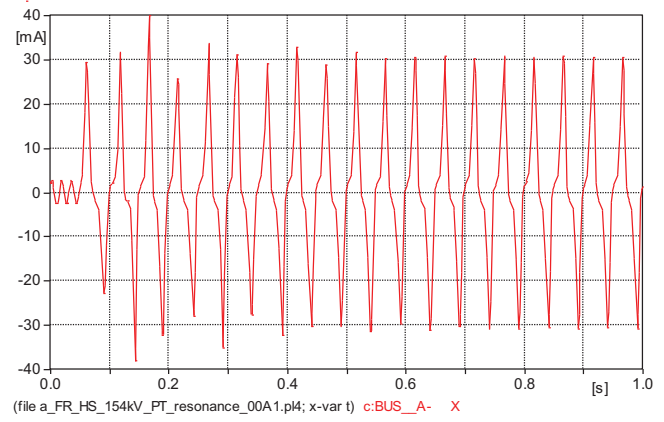

Fig. 12. 1st side current on Ferro-resonance state

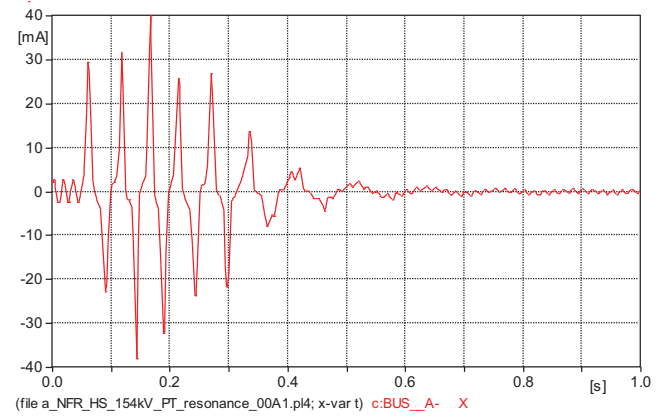

Fig. 13. 1st side current on Divergence reactor application

III. RESULTS ANALYSIS AND DISCUSSION

When applying the divergence reactor to prevent ferro-resonance, the resonance and transient characteristics of the substation system were compared and analyzed in Fig. 8 and Fig. 9 as mentioned in the above section ‘II. System Design and Experiment’. The time to introduce the divergence reactor for the test was set so that SW2 can operate(open) when it reaches the magnetic flux value (Φ_{bkp}) of the linear area immediately before an inflection point of PT saturation starts. Since the divergence reactor is added immediately after SW2 is opened, it is intended to consider simulation results for prevention phenomenon of resonance at this stage.

A. Voltage Variation Analysis at PT 1st side

The ferro-resonance state through EMTP simulation as well as the voltage transition of PT 1st side when inserting the divergence reactor are shown in Fig. 11 and Fig. 12, respectively. The opening of CB has all occurred at 0.05 seconds. It can be seen that the 1st side voltage of ferro-resonance states continue to vibrate at about 110 V without the reduction of 1st side reactor voltage because it resonates after CB is opened.

On the other hand, PT 1st side voltage simulations applying dual reactor are set to open at 0.2 s. As shown in Fig. 10, the results show that the value is vibrating at about 100~110 kV since it resonates until 0.2 s before SW2 is opened and after CD is opened at 0.05 s. It is confirmed that the transient voltage is gradually reduced to less than 20 kV after SW2 is opened at 0.2s.

B. Current Variation Analysis at PT 1st side

Fig. 12 shows the simulation results about 1st side current transition of PT during ferro-resonance. The opening time of CB for the test is set at 0.05 s, It is confirmed that PT 1st side current in the ferro-resonance state continues to vibrate at about 30 mA without reduction of 1st reactor current since it resonates until 0.2 s before SW2 becomes open and after CB is opened at 0.05 s.

When applying the divergence reactor as shown in Fig. 13, the simulation result of 1st side current indicates that the current value stops resonance and is gradually reduced to less than about 1 mA when SW2 is opened again at 0.2 s and after CB is opened at 0.05 s.

C. V, I Variation Analysis at PT 2nd side

When comparing the simulation applying the dual reactor with the existing ferro-resonance simulation, that of the resonance and transient protection circuitry is shown as below. Fig. 14 presents a current trend of 2nd side during ferro-resonance state. CB is set to open at 0.2 s. After the CB is opened, it can be seen that the current continues to resonate at about 1.2 A.

Moreover, in order to simulate the time during insertion of the divergence reactor, SW2 is set to open at -1 s. CB is set to open at 0.2 s which is the same as the above ferro-resonance conditions. Fig. 15 and Fig. 16 show voltage and current transients characteristics of the 2nd side when applying the divergence reactor.

When applying the divergence reactor, the simulation result indicates that the voltage of PT 2nd side gradually decreases from

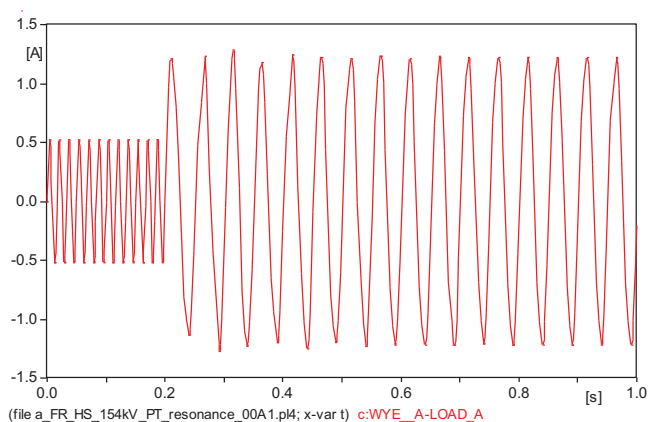

Fig. 14. 2nd side current on Ferro-resonance state

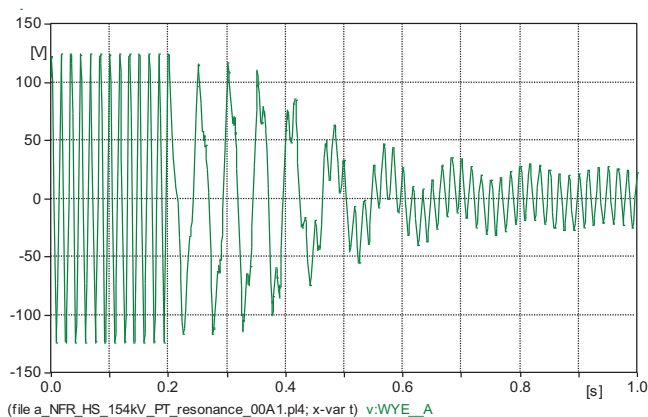

Fig. 15. 2nd's voltage on Divergence Reactor Application

the moment when CB is opened and is reduced to less than 20 V. In addition, it is confirmed that the change in the current value is gradually reduced to less than 0.1 A after generating transient current up to 1.25 A during approximately 0.3 s right after 0.2 s when CB is opened.

D. Current Change of the Extended Divergence Reactor Unit at 1st side

Fig. 17 shows the current simulation result of 1st side extended circuit unit when applying the divergence reactor.

For the test of the extended circuit of 1st side divergence reactor unit, CB is opened at 0.05 s and SW2 is opened at 0.2 s. After that, the divergence reactor is placed.

In this case, the current in the extended divergence reactor unit vibrates with a value of up to 40 mA due to resonance generation after CB is opened at 0.05 s. It can be confirmed that the current value is reduced to a value of almost 0 mA since the resonance phenomenon disappears after the divergence reactor is placed after SW2 is opened at 0.2 s.

E. Results review

In the VT system operated by using the dual reactor method, the extended divergence reactor was added using protective control relay facilities before the saturation starts at VT facilities in an ferro-resonance generation environment at substation system. A simulation test was performed to observe the changing characteristics of voltage and current in VT 1st side and VT 2nd

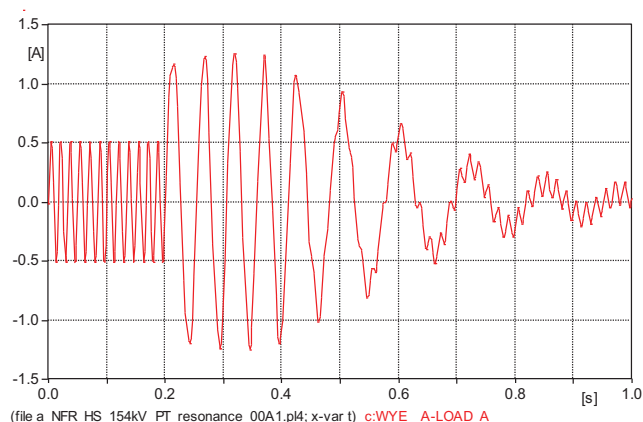

Fig. 16. 2nd's current on Divergence Reactor Application

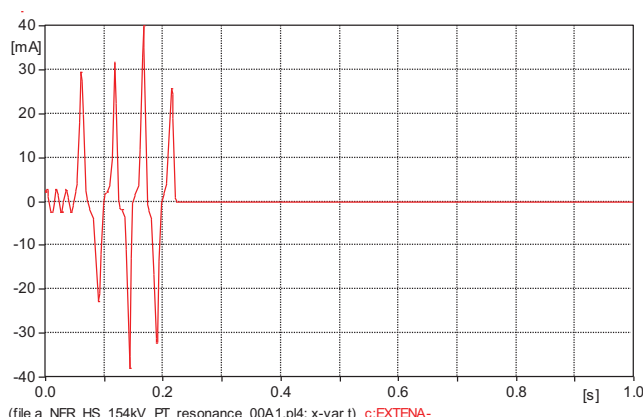

Fig. 17. Current of the extended divergence reactor on 1st side circuit unit

side, respectively. According to the test results, all voltage and current values in the ferro-resonance state continuously generated vibration characteristics. However, after adding the divergence reactor, all voltage and current values were restored to stable and normal values after transients appeared for a short period of time. Therefore, it was confirmed that the ferro-resonance in VT could be prevented in advance.

Finally, when checking and verifying the results of 1st side current in extended divergence reactor unit, it was confirmed that the ferro-resonance transient which started after adding CB completely disappeared within one cycle right after the divergence reactor was inserted. In this test, the ferro-resonance was generated after placing the circuit-breaker. However, the simulation showed that ferro-resonance was blocked after the divergence reactor is inserted. Nevertheless, when it was applied on site, the ferro-resonance was preemptively blocked since the divergence reactor is placed and controlled by the protective control relay unit which automatically determines whether to place the divergence reactor or not before ferro-resonance occurs. Therefore, the reliable operation of the equipment is possible to achieve.

As shown in the above test, the existing damping resistance method and dual reactor method share one common point that the reactor is placed in the system to address ferro-resonance. However, the big differences between the method of applying the saturable reactor in 2nd side of VT and that of applying the divergence reactor in 1st side of VT are in terms of operating characteristics, objective sides, and system stabilization.

First, the saturable reactor method inputs the reactance of saturable reactor in the form of energy consumption through the load resistance in the damping resistance circuit by forming a closed loop in the damping resistance circuit by short action after it is saturated. In this case, the operating reliability of equipment such as protective control can be degraded because the voltage and current ratio between 1st and 2nd sides of VT can be affected by the small voltage drop generated in the damping circuit resistance unit.

On the other hand, since the divergence reactor method is placed before the system is saturated, it prevents the system from being developed into ferro-resonance state. In addition, since the closed circuit through reactor continues to form the open circuit, it prevents equipment unit from being burned out. Therefore, these can allow stable operation of the system, and improve overall system reliability including equipment life etc.

IV. CONCLUSIONS

This paper discussed a simulation test about an operation method applying a dual reactor which prevents the burnout in the substation system, which has a fundamental difference compared to conventional methods in terms of stability and technical aspects.

The advantages of its operational features are described as follows: First, when the substation system is being transformed into ferro-resonance conditions, the magnetic flux within VT increases. At this stage, the ferro-resonance environment is neutralized before reaching the saturation inflection point. Second, when ferro-resonance occurs and significant energy is input from the outside, it does not use the damping resistance like conventional methods since it can cause burnout. During normal operation, the divergence reactor is not put into the system. Even if the system forms a loop after it is placed to control the system, the saturation does not occur. Therefore, the life of a reactor and related equipment are very stable.

Next, regarding the advantage in utilization, first it is significant that first and foremost it increases the safety by preventing system accidents and can secure highly reliable substation operation through a stable power supply. While conventional measures using saturable reactor and damping resistance at the rear of existing 2nd side, the new method proposed in this paper uses an extended divergence reactor in the 1st side. This may seem similar to each other in terms of their application methods using a reactor; however, it has complete technical and conceptual differences in terms of operational methods and conditions as well as the role of the device, etc. In

other words, the basic function of the saturable reactor can enable damping resistance and protect the system only when it is saturated.

Second, while it is initially excluded from the line of the system, the divergence reactor application method play a role of preventing under such conditions becoming resonant and saturated by being directly placed after automatically detecting the condition before the system becomes saturated and resonant. Therefore, the divergence reactor can improve the operational reliability of the equipment since it is not saturated when it is put in and in operation.

In conclusion, when the saturable reactor is frequently operated, it will lose the unique saturation characteristics and, furthermore, it can lead to burnout due to the destruction of insulation, etc. After that, even if transient ferro-resonance occurs, it is no longer possible to interrupt the ferro-resonance. In this case, since it is impossible to suppress saturation, VT will inevitably be burned.

Based on the simulation results up to this point, it is necessary to conduct empirical tests on a laboratory scale in the future. Since the digitalization in recent system facility is accelerating through automation, rather than finding measures after the failure occurs, it would be desirable to stabilize the equipment through pre-emptive research in order to prevent the occurrence of erroneous operation resulted from a variety of internal and external shocks in the system.

REFERENCES

- [1] J.W.Woo, E.B Shim, "A analysis result on the PT ferroresonance at 154kV GIS substation", KIEE, July 19, 1999
- [2] J.E.Lee, "Professional Engineers for Electrical Engineering", www.cspeee.co.kr, 2014
- [3] W.S.Choi, S.K Kim, "Investigation and Countermeasure of P.T Ferroresonance in the 154kV GIS Substation", KIEE, July 10, 2002
- [4] Jae-Gu Choi, Ik-Soo Kim, "Parameter Selection of the Saturable Reactor for Removing Ferroresonance of 362 Kv Gas VT using EMTP", KIEE, Vol. 50C, No. 4, APR, 2001
- [5] S.K.Kim, "An empirical study on a fault phenomenon for the power supply circuit of the network based power IT instrument by a surge transient characteristics", KIEE, April 25, 2014
- [6] EMTP Primer, EPRI EL-4202, Project 2149-1, Final Report, September 1985