

Development of Multi-Purpose Containers for Managing LLW/VLLW from D&D

제염해체 방사성폐기물 관리를 위한 다목적 용기의 개발

Jaesol Lee*, Jeaho Park, Nakhoon Sung, and Gehyung Yang
 KONES Corporation., 5F, 65, Myeongdal-ro, Seocho-gu, Seoul, Republic of Korea

이재설*, 박제호, 성낙훈, 양계형
 (주)코네스코퍼레이션, 서울 서초구 명달로 65, 일흥스포타운 5층

(Received December 18, 2015 / Revised January 25, 2016 / Approved February 24, 2016)

Radioactive waste container designs should comply with the requirements for safety (i.e., transportation, storage, disposal) and other criteria such as economics and technology. These criteria are also applicable to the future management of the large amount of LLW and VLLW to arise from decontamination and decommissioning (D&D) of nuclear power plants, which have different features compared to that of wastes from operation and maintenance (O&M).

This paper proposes to develop a set of standard containers of multi-purpose usage for transportation, storage and disposal. The concepts of the containers were optimized for management of D&D wastes in consideration of national system for radioactive waste management, in particular the Gyeongju Repository and associated infrastructures. A set of prototype containers were designed and built : a soft bag for VLLW, two metallic containers for VLLW/LLW (a standard IP2 container for sea transport and ISO container for road transport). Safety analyses by simulation and tests of these designs show they are in compliance with the regulatory requirements. A further development of a container with concrete is foreseen for 2016.

Keywords: Radioactive waste, LLW and VLLW, Standard ISO containers, D&D waste

* Corresponding Author.

Jaesol Lee, KONES Corporation, E-mail: jaesollee@kones21.com, Tel: +82-10-6800-5095

ORCID

Jaesol Lee <http://orcid.org/0000-0002-9384-2658>
 Nakhoon Sung <http://orcid.org/0000-0001-5252-0647>

Jeaho Park <http://orcid.org/0000-0003-2112-1955>
 Gehyung Yang <http://orcid.org/0000-0001-7405-4341>

방사성폐기물용기의 설계는 용도 (운반, 저장, 처분)의 안전요건에 부합돼야 할 뿐 아니라 경제성과 기술적 기준도 만족해야 한다. 이러한 기준은 장차 원전해체로부터 발생할 다량의 저준위/극저준위 해체폐기물의 관리에도 해당된다. 해체폐기물의 특성은 원전운영에서 발생하는 방사성폐기물과는 매우 다르므로 적합한 용기의 개발이 요구된다.

이 논문은 다목적용도의 표준용기 개발을 제시한다. 이 개념은 경주처분장과 같은 국가 인프라를 고려한 원전해체폐기물의 관리를 최적화하기 위한 용기이다. 이 연구는 일련의 시제품을 설계 또는 제작한 것이다 : 극저준위용 소프트백, 저준위용 금속용기 (해상운반용 표준 IP2 용기 및 도로운반용 ISO 용기), 이들 용기 설계의 안전성 분석을 위한 시뮬레이션 및 시험결과 는 규제요건에 잘 부합되는 것으로 나타났다. 콘크리트 용기의 후속개발은 2016년에 수행예정이다.

중심단어: 방사성 폐기물, 저준위/극저준위, ISO 용기, 원전해체폐기물

1. Introduction

One of the key issues associated D&D of nuclear facilities is rational management of resulting wastes which consist mostly of LLW and VLLW. As the infrastructure and regulatory systems for radioactive waste management had initially been established for O&M wastes, a compatible system optimized for D&D wastes would be needed. A method to optimize the system is to use multi-functional container for packaging, transport and disposal with a view to maximize economics and efficiency and also minimize dose risks. The bulk amount of VLLW from D&D can be packaged in large capacity multi-purpose containers for direct disposal, instead of using the traditional drum-based system for O&M wastes, based on the additional classification of VLLW by IAEA, announced in 2009, applicable to the large amount of wastes arising from D&D [1].

A review of some global trend in packaging D&D wastes are as following:

- Soft bag containers

For practical and economic reasons, soft bags that had been previously used for garbage packaging has been adopted for VLLW management in the US, followed by Europe. The VLLW packaged in large size multi-functional soft bags are transported for landfill disposal. More recently, soft bags are introduced in Asia, in particular for

packaging the soil wastes for temporary storage at such site around Fukushima [2].

- ISO containers

A pioneering example of transition from traditional drums to ISO containers had been the initiative taken by Croft Associate in the nineties in UK [3]. The large capacity ISO standard containers, transportable and disposable, have efficiently been used for managing the large amount of LLW, as highlighted by the Drigg repository. The UK example stimulated wider use of ISO containers for managing LLW and VLLW on global basis.

- Concrete container

Concrete containers have been used for strengthening structure, resistance to radiation and corrosion, compared to the steel container. A technical issue of the concrete containers for multi-purpose usage is transportability, due to the fragile property of concrete materials. This technical problem was alleviated by reinforcement with amorphous steel fibre in such transportable container as Sogefibre which was adopted by ANDRA in France and VUJE in Slovakia [4]. More recently, the Dounreay Site Restoration Ltd (DSRL) in Scotland has also launched a test use of a large concrete container of HHISO standard (14.7 m³) for on-site transport and disposal of LLW, alongside with the standard ISO containers in carbon steel [5]. This implies

the possible direction of future development in concrete container with larger capacity for enhancement of not only of efficiency but also of safety.

Multi-purpose concrete container might emerge from ultra-high performance concrete (UHPC) technology. Albeit not yet been applied to radioactive waste packaging, the UHPC concrete bears potential to be competitive with the existing options [6].

Adopting of large capacity containers will also result in significant saving of disposal space, by dint of more compact packing of the containers in the repository than cylindrical drums in disposal containers.

1.1 Need for D&D Waste Management in Korea

Due to the impacts from Fukushima Accident, public debate on nuclear power has been mounting in Korea and the utility has recently decided no further extension of operational life of Kori #1 which is by consequence to be decommissioned in a decade. On the other hand, the Government has already launched, national plans for R&D, since several years, in technological preparation for the future D&D of NPPs and subsequent waste management. Korean nuclear industry has to prepare for the advent D&D of NPPs in the coming decades, together with suitable systems for management of radioactive wastes arising thereof.

1.1.1 Radioactive Wastes arising from D&D

The amount of radioactive wastes arising from D&D of nuclear power plants is not easy to estimate because of the assumptions made on various factors associated with plant operations. An estimate by KORAD on the cumulative amount of radioactive waste arising from nuclear power plants, both by O&M and D&D, projected to the year 2090 is given as Table 1 [7] :

This amount is based on an assumption for LLW/VLLW arising from D&D for a PWR unit of 900~1,300 MWe, which could be converted to a volume of 13,000 drums of 200 liters, with assumptions on packing densities for

Table 1. Projected amount of radioactive wastes arising from O&M and D&D of NPPs in Korea
(Unit : 200 liter drum)

YEAR	O&M	D&D	TOTAL
2020	112,882	-	112,882
2030	148,872	5,800	202,717
2040	198,602	174,000	433,417
2050	238,562	243,600	557,847
2060	250,122	307,400	640,677
2070	260,452	348,000	699,077
2090	268,952	348,000	715,047

metal 2.3 ton/m³, for concrete 2.3 ton/m³, and for others 0.8 ton/m³ and packing rate 85% in drums.

Availability of waste repository is a prerequisite not only for disposal of radioactive wastes from O&M but also from D&D as well. In this context, the recently inaugurated Gyeongju repository is a critical national asset being operated by KORAD. At this initial phase of the repository operation, however, the system design is optimized for managing O&M wastes for LLW. With the advent need for managing D&D wastes in the longer term, appropriate optimization will be required for overall system design at the repository with special considerations for managing VLLW.

1.1.2 Needs for Optimization

The radioactive wastes arising from D&D of nuclear power plants have different features from those arising from O&M, in terms of form and content. The D&D wastes consist of predominant volume of VLLW, in contrast to O&M wastes which are predominant with LLW. Such difference should be considered in the future development of waste management system which had initially been built for managing O&M wastes.

Now that the national infrastructure for managing radioactive wastes having been built in Gyeongju, a careful consideration is to be given to the optimal plan for the future operation of the existing infrastructure. Considering the large amount of VLLW to arise from D&D, develop-

ment of disposal facility for landfill burial of VLLW will be desirable, in addition to the vault type being planned for LLW disposal. For some D&D waste with shorter half-lives, temporary storage in the existing facility for adequate period of decay time, could be considered for later clearance.

1.2 Review of National Systems for Radioactive Waste Management

As the Gyeongju repository has just been built, as the core facility of national radioactive waste management system, the development of future waste management system will have to address the D&D waste management, as well as the current system which has focused thus far on O&M wastes.

1.2.1 Waste Packages

While there are a variety of waste packaging methods introduced in Korea, the basic method is to use the standard steel drum of 200 or 320 liter capacity which have been commonly used for packaging LLW arising from O&M of NPPs. Considering the difference of D&D wastes from O&M wastes, optimization of waste packages in consideration of both types of wastes will be desired at longer term.

1.2.2 Logistics for Managing D&D Wastes

In consideration of the nuclear power stations located at coastal shores, the infrastructure for O&M waste transportation system was built for sea transport from nuclear power plants to Gyeongju repository. The transport ship (Hanjin Cheonjeongnuri, see Fig. 1) has handling system of waste packages with the capacity limited to a weight of 7.5 MT and with transport container dimensions 3,400 (L) × 1,600 (W) × 1,200 (H) in mm unit. The transport container is made of steel and is loadable with 8 drums of the 200 liter capacity.

The transport container is dedicated only to transportation of the waste packages in drum to the repository, where it is unloaded for reuse (see Fig. 1).



Fig. 1. Radioactive waste transport ship - Hanjin Cheonjeongnuri [7].

Given such infrastructure, the dimension of the new multi-purpose container design for D&D wastes is to fit to the same dimensions and rigging as the existing transport container, in order to be able to use the existing handling systems at the harbor, the ship and the repository. Otherwise, a new design of the infrastructure would be required to be built in order to handle waste package of different designs (i.e. ISO container).

1.2.3 Disposal in the Repository

The design of radioactive waste repository at the Gyeongju site was initiated a decade ago when the current repository site was decided by local referendum. The first phase construction of the Gyeongju repository built is of silo type in tunnel, reflecting the primary concern for safe management of O&M wastes of LLW class. The waste drums transported to the repository is unloaded from the transportation container at the reception facility and upon inspection transferred into a disposal container, made of concrete, which can be loaded with 16 drums.

The possibility of disposal of D&D wastes at the Gyeongju repository can be reviewed for each of the following classes of new classification system:

- ILW

The disposal of ILW wastes, arising both from O&M and D&D of nuclear facilities, is still controversial about

the optimal disposal measures in Korea and abroad. In view of the relatively small amount of ILW, but higher hazard requiring deeper isolation, most of the ILW wastes are in general stored at the source site for future solutions.

- LLW

The LLW packages from O&M are the main stream of radioactive wastes to be disposed of in the Gyeongju repository of silo type. The suitability of disposing D&D wastes of LLW class in this silo is an issue to study, however, due to the high cost of disposal being charged to the O&M wastes. It will also depend on the optimal design of the disposal packages of D&D wastes for which large capacity multi-purpose packages are considered to be more economical. If it proves to be better to dispose of the D&D wastes in larger containers of ISO standard, the current infrastructure of the repository and transport may better be designed for such new system than retrofitting to the existing system.

- VLLW

With the emerging need for managing D&D wastes, a strategy for harmonizing the infrastructure for wastes from different sources is thus called for. One of the key strategy would be the consideration for the large amount of VLLW arising from D&D, with little hazard, compared to O&M wastes.

Having recognized the need for D&D waste management in the future, KORAD has been elaborating a plan for land use at the Gyeongju repository site (Fig. 2). Currently, a plan for developing shallow land disposal in engineered barrier is being implemented for LLW [8].

KORAD has a rough plan for further stages of land-fill disposal for the large amount of VLLW to arise from D&D. In view of the cost optimization, a suitable place adjacent to the existing facilities would need to be secured in the future (In reference to other countries having already disposed of large amount of VLLW, waste packaging in soft bag container disposal in surface burial would be adequate at such site).



Fig. 2. Site plan for Gyeongju repository.

1.3 New Systems for D&D Waste Management

There are two options that can be considered for future transportation of D&D wastes : use the existing infrastructure, or develop a new system additionally to the existing system. In addition to the established infrastructure for radioactive waste transportation, some new system concept for managing D&D waste packages can be developed, if justifiable by consideration of relevant criteria, such as :

- A possibility to come up with a container which is compatible with the existing infrastructure for O&M waste management. This container can be optimized, for future management of D&D wastes.
- An alternative to the existing system by adopting of ISO freight containers which has been widely used in the US and in Europe.

In this study, a steel container design for the former and another for the latter have been proposed, as to be described later part.

1.4 Container Development

Initially developed by the reactor vendors for managing radioactive wastes, steel drums of 200 or 320 liters are widely used around the world as the basic unit for O&M wastes arising from nuclear facilities. Korea was no exception in the global trend adopting the drum as a basis for

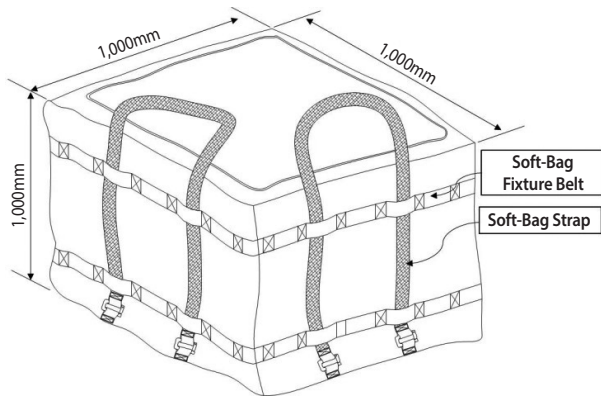

Fig. 3. Soft bag design.

packaging LLW from PWRs. However, the small drums are not efficient for packaging D&D wastes of which radioactivity levels are in general lower while quantities are large.

An important consideration on the concept of container, especially for D&D waste package, is multiple functions of the container. As reviewed previously, the current system is designed for single purpose: dedicated container for transportation and disposal, respectively. If the container is designed to be multi-purpose, the waste package can be directly transported and disposed of in the repository, on the condition of compliance with all the safety requirements, with consequent benefits in economics, efficiency, and dose reduction.

2. Development of Standard Containers

Containers are the basic unit to make waste package and therefore play a critical role as a barrier against release of radioactive substances from the package during storage, transport, and disposal. The waste package should comply with relevant requirements for safety and efficiency set forth for each of the required operations. It's up to the waste operator to come up with the most optimal container in compliance with the relevant requirements of the regulatory authority.

In the context of D&D waste management, the follow-

ing types of multi-purpose containers have been proposed by KONES for the container development project:

- Soft bag
- Carbon steel containers
- Concrete containers

Among the three types of containers, the soft bag and steel containers have been developed during 2014-2015. Based on optimized concepts a set of containers for prototypical demonstration were designed [9].

2.1 Soft bag

Soft bag as a container for VLLW has recently become popular in the global market for D&D waste management, mainly for efficient and cost-effective packaging. Given the large amount of concrete rubbles, and possibly contaminated soils, of VLLW class arising from D&D, soft bags can be widely used for multi-purpose packaging for transport and disposal. While experience with soft bag disposal is limited, recent developments expect its usage for IP2, to be competitive with ISO containers, with the added benefit of not needing grouting [10].

Having noticed such trends, KONES has developed the soft bag for domestic production. The dimensions of the soft bag developed are 1,000×1,000×1,000 in mm and the weight is 1,200 kg (with content). The container is made of synthetic fiber with triple barriers and fixed with belts around the 4 faces and a cover with a couple of zippers (Fig. 3).

- The outer wrap is made of woven fabric of polypropylene outside of which is coated with liquid propylene for anti-moisture.
- The inner barrier is non-woven fabric of PET (polyethylene terephthalate) for dampening of internal impacts inside of which is coated with polyurethane. Upper cover is also fitted with a couple of zippers.
- The inner envelope consists of HDPE vinyl sheets in

double layer, with the inner side reinforced for resistance with contact for wastes. It can completely wrap around the opening of the soft bag (Fig. 4).

2.2 Steel Containers

As previously reviewed, a couple of options can be foreseen for development of logistics for D&D waste management : either use of existing infrastructure built initially for O&M wastes, or develop a new system optimized for D&D wastes. In consideration of these cases, a set of two containers were developed as following:

- An IP2 type steel container which is compatible with the existing transport container for sea transport
- Another ISO type steel container of half-height standard (HHISO) for truck transport on road,

While the former is compatible with the established logistical system, the concept behind the container design is different from the current transport container. The IP2 container is for multi-purpose, and thus is directly disposable in the repository. It is based on the scenario that this kind of D&D waste package would be disposed of in the LLW vault being planned, or in a new VLLW repository to be developed.

The ISO container of the latter case is a new design dedicated for D&D waste management, either for truck transport on road (or sea transport with a new infrastruc-

ture if developed) although there have been some limited usages of ISO container for radioactive waste in Korea. Just as the IP2 container, the proposed ISO container is multi-purpose that is directly disposable in the repository.

Both of the steel containers make use of stillage for handling and fixing wastes in the container. The use of stillage is a technical feature of the container to deal with a variety of different waste forms to be packaged in the container. A variety of stillage designs could be used for handling different kind of waste forms and contents (Fig. 5).

The body and cover of the IP2 and ISO containers are made of carbon steel (SS 400). The container body is structurally reinforced by supportive frame (SPSR 400) and the cover to be bolted on the body is lined on the corners with bumper material of rubber (EPPM).

The specifications of the ISO containers are summarized in Table 2.

The containers have two pockets in the floor of the container frame for handling of the containers by fork lift,



Fig. 4. Soft bag (prototype).

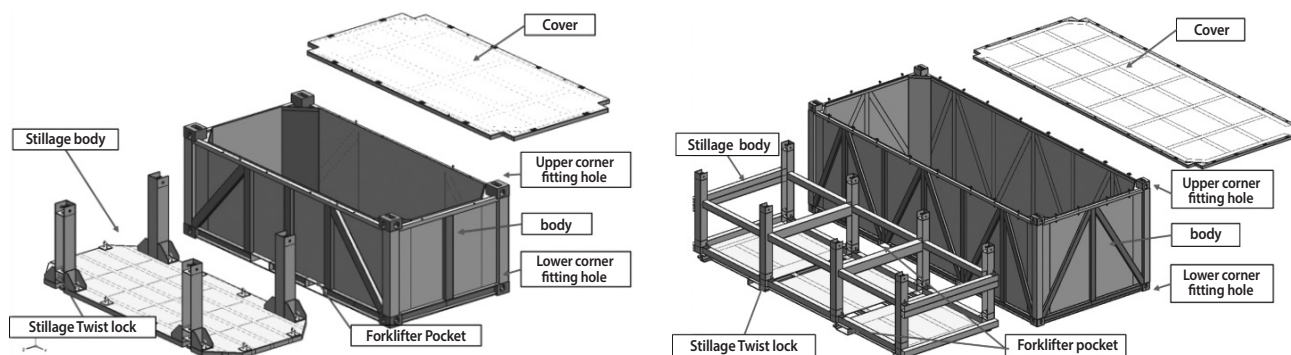

Fig. 5. Designs of IP2 and ISO containers.

Table 2. Specifications of the IP2 and ISO containers

Container	Specification		Remark
	Dimension (Outside, in mm)	Weight (t)	
IP2	3,400 (L)×1,600 (W)×1,200 (H)	7.5 (Empty : 2.28 t)	Same dimension as the current transport container
HHISO	6,000 (L)×2,400 (W)×1,200 (H)	20 (Empty : 6.8 t)	Standard ISO container specification



Fig. 6. Soft bag tests.

For fixing the stillage on the floor or the containers on the truck twist locks are used.

An important issue in the consideration of D&D waste container is adherence to the industrial standards, especially to the ISO standards for freight containers. This is especially the case for Korea considering the need for transportation of the waste packages by ship due to the siting of NPPs at coastal locations. The implications of such international standards to handle and transport D&D waste packages are well known. Aside from the economic advantage of using competitively available commodity at large quantities, the international safety standard on shipping (CSC) can be beneficial feature for system compatibility in marine transportation. It is also quite common to see abroad used ISO containers reused for direct disposal of waste packages.

2.3 Concrete containers

For some D&D waste of higher level radioactivity, shielding of waste packages by the steel containers may not be adequate. In such case, additional shielding with concrete materials may have to be required.

As indicated above, the interesting technology of UHPC could lead to development of multi-purpose con-

crete containers, which will require substantial efforts for engineering and tests.

3. Results of Container Developments

In the second year of project implementation, KONES has focused on the development of two types of containers for the D&D waste management:

- Soft bag
- Metal containers

3.1 Soft Bag

In reference to the UK development in soft bag, the prototype product developed was tested under the applicable safety requirements [11].

A summary of the tests is given below.

- Stacking: Applying 5 times of the loaded weight (i.e., 1.2 t) which is 6 t, the test demonstrates the soft bag resisted up to 7.1 t.
- Drop: The applicable drop height of 1.2 m with loaded (sand) weight of 1.2 t was tested at various angles as required.
- Lifting: A lifting test with 3 time the loaded weight (1.2 t) was conducted successfully for 3.6 t.

In addition to these basic tests, operational tests with various conditions were successfully conducted in compliance with the safety requirements (Fig. 6).

Table 3. Drop test conditions

Package Weight (kg)	Drop (m)
Weight <5,000	1.2
5,000 ≤ Weight < 10,000	0.9
10,000 ≤ Weight < 15,000	0.6
15,000 ≤ Weight	0.3

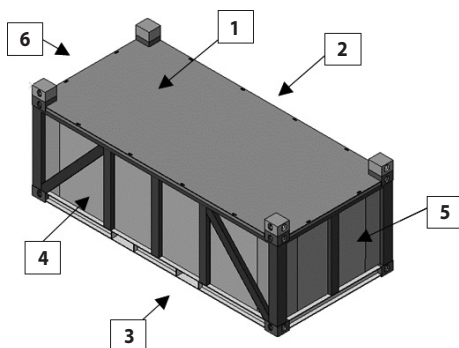

Fig. 7. Identification of impact positions.

3.2 Steel Containers

For the steel containers, the IP2 model was analyzed by simulations to check compliances with safety requirements.

The key requirements applicable to the safety of the container (NSSC Decree No. 2014-50, article 24-2) can be summarized as following:

- Containment of radioactivity (lid opening below 100 % is regarded as no loss of content)
- Shielding of radiation (loss of shielding should not cause more than 20% of dose rate to external surface)
- Structural integrity (drop, stacking, lifting, locking) should be maintained at conditions of test requirements

The analyses were conducted by finite element method (FEM) by use of ABAQUS 6.10. A friction coefficient of 0.2 was assumed for contacts between steel parts, with contact conditions (General Contact) provided by ABAQUS. The dynamic analysis was based on initial velocity and drop

impacts for the IP2 container design (Fig. 7).

Based on the FEM analysis modeling of each part and center of gravity, the results of the analysis by simulations of the IP2 containers can be summarized as the Table 4.

The duration of the stacking test is 24 hours. As to the drop analysis, stress limits were calculated to be the ultimate (or true) stress of physical break point, based on the NSSC Notice No. 2014-50 which requires no loss of content from the container due to the drop (without any numerical specification for IP2 container). As each of the local maximum stress in the Table 4 is not critical to the overall structural safety of the container, respective values in the table have adequate safety margin with respect to the Stress Limits (full report on the analysis in Reference 9).

4. Future Plans

This paper gave the results of the second year of R&D project, as conducted by KONES Corporation, for development of containers for D&D waste management. Future plans for the project are as following.

4.1 Steel Containers

A prototype of IP2 steel container was fabricated for later tests to check compliance with safety requirements. In reference to the simulation results, physical tests are to be conducted for the prototype container.

Simulation of HHISO container is to be conducted in 2016, to be followed by safety tests with prototype fabrication.

Appropriate preparations are undergoing for later tests of these steel containers.

4.2 Concrete Containers

Concrete containers have been in development for optimal design and tests. A review of the past development of concrete containers was conducted, with special focus

Table 4. Results of the stress analysis by simulations for design of the IP2 container

ANALYSIS (see legend on Fig. 7)		Maximum Stress [MPa]								
		Body Plate	Cover Plate	Body Frame & Support	Cover Support Frame	Fork Lift Pocket	Bottom Corner Fitting	Top Corner Fitting	Cover Bolt	RESULTS
Stacking Analysis		8.2	0.1	84.7	0.1	1.1	50.9	25.9	0.1	OK
Drop	Bottom Side (3)	245.4	230.9	294.2	259.0	296.0	219.3	304.2	549.9	OK
	Top Side (1)	237.2	237.4	300.9	297.3	213.1	322.0	286.0	640.7	OK
	Larger Sidewall (4)	403.1	239.7	417.7	273.1	163.7	397.3	411.3	724.4	OK
	Smaller Sidewall (5)	297.9	238.0	435.8	255.4	159.4	311.6	402.5	510.1	OK
	Top Longer Edge (1-5)	391.5	234.9	460.9	289.3	290.0	524.2	463.8	580.1	OK
	Top Shorter Edge (1-4)	297.6	230.4	405.6	297.9	261.9	483.8	410.8	561.6	OK
	Top Corner Fitting (1-4-5)	467.1	413.1	485.9	406.9	304.1	574.1	544.1	630.3	OK
	Bottom Side Shorter Edge (3-5)	387.6	192.9	417.7	198.1	216.1	318.2	500.6	365.5	OK
	Bottom Side Longer Edge (3-4)	443.2	280.1	478.2	231.2	233.1	431.9	574.2	354.3	OK
	Bottom Corner Fitting* (3-4-5)	477.6	201.3	490.2	241.5	288.5	482.3	575.1	552.7	OK
Requirements/ Criteria (Stress Limits)		484.0		492.0			576.0		914.2	-

* Some other sources use such terminology as “casting”, instead of Fitting (ex. www.containerhandbuch.de)

on multi-functional applications, such as the use of Sogefibre product and possible development of Ductal type UHPC container in France [12]. It was revealed from the review that the recent development of UHPC also in Korea might provide a new way to develop multi-purpose concrete containers that could be competitive to other type of materials such as steel [13].

A prototype of UHPC container is in plan for development in 2016, in a step behind to the developmental activities of steel containers. The result of this development is due to the 2015-2016 time frame.

5. Conclusion

The study revealed that radioactive wastes arising from D&D of nuclear facilities bear very different features from those arising from O&M. It is therefore desirable to de-

velop containers that are optimized for rational management of D&D wastes, for which KONES conducted a R&D project for container development.

The category of radioactive wastes arising from D&D of nuclear facilities could be packaged in containers of the following type:

- Majority of VLLW and some lower level of LLW of D&D wastes can be packaged in soft bags for transport and disposal (ample examples in the US and Europe).
- In pursuit of compatibility with the existing system for radioactive waste management, however, a multi-purpose steel IP2 container which is compatible with the current system for radioactive waste management of Gyeongju repository is developed, and an alternative design with ISO standards for road transport was developed
- Multi-purpose containers with concrete materials can be developed based on the recent development

of ultra-high performance concrete which could be competitive to steel containers

The use of large capacity containers, in lieu of small capacity drums, can maximize system O&M efficiency and consequently reduce dose to workers, as well as the significant savings in the repository volume by reduction of idle space between drums in the disposal container.

Regarding the need for standardization, adoption of ISO standard is the recommended option for the following rationales:

- The advantages of ISO containers in compliance with the industrial standards can be adopted for the multi-purpose packaging for transport, storage and disposal. On the other hand, ISO container of reusable type has the versatility to load with untreated and treated wastes
- Strategy for future market in compliance with national and international industrial requirements for freight transactions

Several container models for D&D waste management is being conceived for development, based on these rationales in the framework of this development by KONES Corporation.

Acknowledgements

This study was supported by Korea Energy Technology Evaluation Program (KETEP) managed by the Ministry of Commerce, Industry and Energy (MCIE). As the beneficiary of the of the KETEP fund, KONES express its gratitude for the financial support provided by KETEP.

REFERENCES

- [1] International Atomic Energy Agency, "Classification of Radioactive Waste", General Safety Guide, IAEA Safety Standards Series No. GSG-1, Vienna (2009).
- [2] M. Sanchez and P. A. Miskimin, "Soft-sided Packaging for Low-Activity Radioactive Wastes", Nuclear Decommissioning Report, June 16, 2011 (Accessed on 31 May 2016, Available from : <http://ndreport.com/soft-sided-packaging-for-low-activity-radioactive-wastes-2/>).
- [3] M. C. Janicki and R. A. Vaughan, "The Development of ISO Freight Containers as IP-2 Packagings", Proceedings of the PATRAM 92, Paper 20-4 (1992).
- [4] L. Ehn, V. Michal, and A. Pekar, "Management of LLW from Underground Tank of NPP A-1 in Slovakia – Retrieval, Treatment, Transport and Disposal", Proceedings of the WM'05 Conference, Tucson, Arizona (2005).
- [5] Graham Beaven, "Delivery Highlight of Concrete HHISOs" in National Programme Update - Delivery Overview Group (March 2014) (Accessed on 31 May 2016, Available from : <http://llwrsite.com/wp-content/uploads/2013/03/March-2014-DOG-Presentations.pdf>)
- [6] United States Department of Transportation, "Ultra-High Performance Concrete: A State-of-the-Art Report for the Bridge Community", USDOT Publication No. FHWA-HRT-13-060 (2013).
- [7] Woo-Geun Lee, "A thousand drums of radwaste moved from Uljin to Gyeongju by Chengjeong nuri" Uljin News Jan. 3, 2011 (in Korean), (Accessed on 31 May 2016, Available from: <http://www.uljinnews.co.kr/news/articleView.html?idxno=10168>)
- [8] Korea Radioactive Waste Management Society, Proceedings of Radioactive Waste and Spent Fuel Management Policy Seminar, INTEC Auditorium, KAERI, Daejeon, Korea (2015).
- [9] KONES Corporation, "Development of Standard Metal and Concrete Containers for Packaging D&D Wastes", 2nd Year Report to KETEP (2015).
- [10] PT&C (Project Time and Cost International LLC), "Development of Standard Containers for Very Low Level (VLLW) and Low Level Waste (LLW) Management - Packaging, Transport, and Disposal of PWR D&D Materials", Report to KONES Corporation (2014).

- [11] International Standard Organization, ISO 1496-1
“Freight Containers – Specification and Testing” Part 1-
General Cargo Containers for General Purpose (2013).
- [12] J-F Batoz, M. Behloul, “UHPFRC development on the
last two decades: An overview”, Proceedings of the
UHPFRC2009, Marseille, France (2009).
- [13] Young-Jin Kim, Sung-Yong Park, Jong-Sup Park, and
Byung-Suk Kim, “State-of-the-art of UHPC Appli-
cations in the World” (in Korean), KICT Newsletter
- Vol. 61, No. 2 (2013).