



Optimization of Algerian *Thymus fontanesii* Boiss. & Reut Essential Oil Extraction by Electromagnetic Induction Heating

Lamia Sid Ali^{1,*}, Moussa Brada¹, Marie-Laure Fauconnier², and Thierry Kenne²

¹Laboratoire de Valorisation des Substances Naturelles, Université Djilali Bounaama de Khemis-Miliana, Route de Theniet El-Had, W. Aïn-Defla 44225, Algeria

²Département Agro Bio Chem, Chimie Générale et Organique, Gembloux Agro Bio Tech Université de Liège, B-5030 Gembloux, Belgium

Abstract – The present study deals with the determination of optimal values of operating parameters such as the temperature of heating, the mass of the plant material and the volume of water leading to the best yield of electromagnetic induction (EMI) heating extraction of Algerian *Thymus fontanesii* essential oil. After an appropriate choice of the three critical variables, eight experiments led to a mathematical model as a first-degree polynomial presenting the response function (yield) in the relation to the operating parameters. From the retained model, we were able to calculate the average response, the different effects and their interactions. The maximum of essential oil recovery percentage relative to the initial mass of plant material was 1.69%, and was obtained at (140 °C, 250 g and 4.5 L). The chemical composition of the Algerian *T. fontanesii* essential oil under the obtained optimal conditions (140 °C, 250 g and 4.5 L), determined by GC/MS and GC/FID, revealed the presence of major components such as: carvacrol (70.6 ± 0.1%), followed by p-cymene (8.2 ± 0.2%).

Keywords – *Thymus fontanesii*, Electromagnetic induction heating, Essential oil, Optimization, Chemical composition, Carvacrol

Introduction

The genus *Thymus* L. (Lamiaceae) consists of 928 species, native to Europe, and growing in the Mediterranean basin and northern Europe, as well as other parts of the world such as Asia, South America, and Australia.¹⁻² Thyme is a largely used medicinal plant. In ancient times it was used by the Egyptians as unguents for embalming and then by the Greeks and Romans for its therapeutic purposes.³ It's used for its expectorant, spasmolytic and antiseptic properties and infusions are used for treating ulcers, dermatitis and rheumatic pains.⁴

Thymus oils as well as *Thymus* extracts are widely used in pharmaceutical, cosmetic and perfume industry, for flavoring and preservation of several food products.⁵ While they are characterized by a large amount of monoterpenes, which normally account for 80% of oil. Thymol and carvacrol occur more frequently, always accompanied by the couple p-cymene, γ -terpinene, the

four monoterpenes being biogenetically closely correlated.⁶ Also linalool, borneol, 1,8-cineole are often present, although in lesser amount.⁷ *T. fontanesii* Boiss. & Reut is one of the eleven species presented in the flora of Algeria. It is a spontaneous aromatic plant endemic to Algeria and Tunisia,⁸ their aerial parts have been highly recommended, were commonly used as herbal teas, condiment and spices, so as for various medicinal purposes.⁷ Essential oils are obtained from plant raw material by several extraction methods.⁹⁻¹⁰ Such methods could be classified into two categories: conventional/classical methods and advanced/innovative methods. Investigation in new technologies (ultrasound, microwave) in the last decades has led to the emergence of new innovative and more efficient extraction processes (reduction of extraction time and energy consumption increase of extraction yield in improvement of essential oils quality).¹¹

The aim of this paper is to show the new method of extraction, reported by electromagnetic induction heating, some advantages of this isolation method; and to optimize the effect of the main operating parameters on the yield of extraction and chemical composition of *T. fontanesii* essential oil.

*Author for correspondence

Lamia Sid Ali, Laboratoire de Valorisation des Substances Naturelles, Université Djilali Bounaama de Khemis-Miliana, Route de Theniet El-Had, W. Aïn-Defla 44225, Algeria
Tel: +213781373828; E-mail: lamia_sidali@hotmail.com

Experimental

General experimental procedures – A pressure cooker (5 L, Chimex, China) was used as a recipient for the mixture of the plant material and water. The EMI heating was done by a hot plate (1800 W, Tristar IK6174, EU). GC was coupled with a flame ionization detector (Thermo – Trace, Interscience, Belgium), using a capillary column coated with 5% phenyl-methyl siloxane (30 m × 0.25 mm × 0.25 μm film Thickness Agilent Technologies, Hewlett-Packard, CA, USA). GC/MS was performed with an Agilent HP 6890, USA), GC system coupled with an Agilent HP 5973 network mass selective detector operated by HP enhanced ChemStation software.

Plant materials – The aerial parts of *T. fontanesii* were collected during the flowering period from Tarik Ibn Ziad (Northern Algeria), localized at N 36°00' latitude and W 2°09' longitude with 630 m altitude. Before being distilled, a voucher specimen (T_{TIZ}-2017-06) of aerial parts was air-dried in the dark and deposited in the herbarium of the agronomic department of Khemis Miliana University.

Extraction method – The aerial parts of *T. fontanesii* were subjected to an electromagnetic induction (EMI) heating assisted extraction. The process (Fig. 1) was equipped with a pressure cooker (5 L capacity), where the raw material and water were kept in. The mixture was then brought to a boil with a hot plate (1800 W), where

the energy transfer to the object to be heated occurs by means of electromagnetic induction. Due to the influence of hot water along with its vapor, the essential oil was freed from the oil glands in the plant tissue. The vapor mixture of water and oil was then condensed in a liquid state using a refrigerant. At the end of the distillation, two phases were observed, an aqueous phase (aromatic water) and an organic phase (essential oil), less dense than water. After 45 min, a time corresponding to static extraction, the essential oil was collected by decantation and dried over anhydrous sodium sulphate, the yield measured, and stored in a freezer at 4 °C in dark glass bottles until use.

Experimental Design – The experimental design methodology (EDM) was applied for:¹²

- Optimization operating conditions of essential oil extraction from the aerial parts of *T. fontanesii* plant by EMI heating.

- Identified the effect of various factors and to find the optimum values of these factors for the maximum response.

Study parameters – In the present study, a three-factors with two-level central composite design were used for optimization the operation condition of EMI heating assisted extraction of *T. fontanesii* yield as follows:

$$R (\%) = (\text{essential oil mass/dried aerial parts mass}^*) \times 100 \quad (1)$$

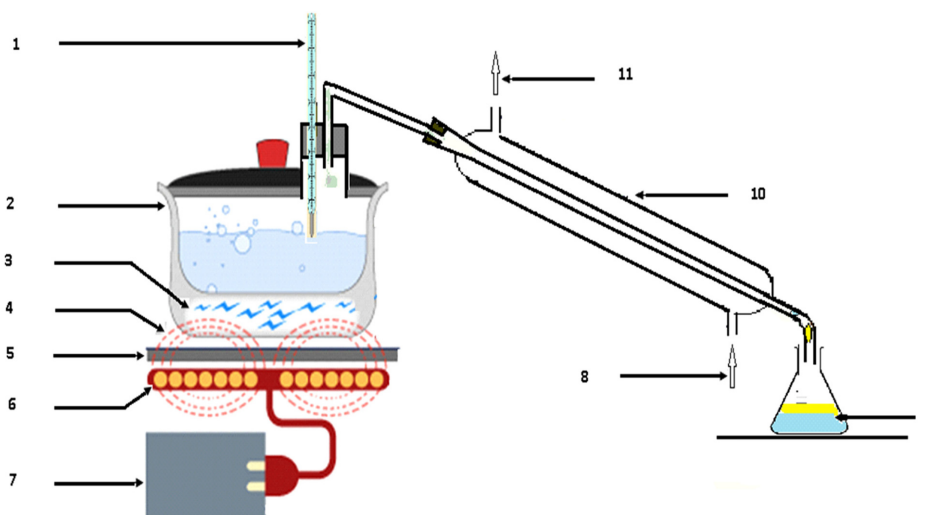

1- Thermometer; 2- Saucepan; 3- Induced current; 4- Magnetic field; 5- Glass-ceramic plate; 6- Induced coils (electromagnet); 7- Power supply; 8- Water inlet; 9- Distillate; 10- Refrigerant; 11- Water outlet.

Fig. 1. Device of electromagnetic induction heating assisted extraction.

The mass* of the plant material for every experiment.

The studied factors were:

- The temperature of heating which is directly related to the steam flux leaving the pressure cooker at the debit of condensation. Two temperatures of heating were used for these parameters tests: 140 °C and 220 °C. This experimental domain had been chosen to ensure an effective and stable extraction. Indeed, heating at a temperature lower than 140 °C increased boiling time, hence the increasing in processing time; and a heating at a temperature higher than 220 °C, caused a refusal of some water in the lateral release tube, which connected the recipient with the distillation column.

- The mass of the plant material and the volume of water have varied between (100 to 250 g) and (2 to 4.5 L) respectively. A quantity of the plant material and volume of water less than 100 g and 2 L respectively caused burring of leaves on the walls of the recipient, while the amount that exceed the 250 g of plant and 4.5 L of water, caused a refusal of some water in the lateral release tube. The Table 1 lists the independent parameter, their symbols and their real and coded levels (-1, +1). A factorial matrix of three factors has been defined. For such a matrix, eight experiments were required for the complete factorial matrix 2^3 .

Mathematical model – In a complete factorial design, a linear mathematical model of the measured response (Y) is often applied for evaluation of the influence of the investigated factors (X_i). This first-degree polynomial is described by equation (2):

$$Y = a_0 + a_1X_1 + a_2X_2 + a_3X_3 + a_{12}X_1X_2 + a_{13}X_1X_3 + a_{23}X_2X_3 + a_{123}X_1X_2X_3 \quad (2)$$

Where: a_0 : represents the average theoretical value of the response. Coefficients a_1 , a_2 and a_3 represent the factor effects of X_1 , X_2 and X_3 . The coefficients a_{12} , a_{13} , a_{23} , and a_{123} represent the interaction effects of $X_1 - X_2$, $X_1 - X_3$, $X_2 - X_3$ and $X_1 - X_2 - X_3$ respectively.

Essential oil analyses – 5 mg of oil was dissolved in 2.5 mL pure diethyl ether and further analyzed by gas chromatography (GC-FID) and gas chromatography-mass spectrometry (GC-MS).

GC-FID: – The analysis of the extracted oil was carried out by means of a HP 6890A gas chromatograph fitted with FID. Using a capillary column coated with 5% phenyl-methylsiloxane (30 m × 0.25 mm × 0.25 μm film thickness Agilent Technologies, Hewlett-Packard, CA, USA); column temperature program was the following: from 40 °C (1 min) to 200 °C at 6 °C/min, 200 - 280 °C at 30 °C/min, 280 °C (final hold of 2 min). The injections have been performed in splitless mode and injector temperature was set at 280 °C; detector temperature 300 °C; volume injected, 1 μL of diluted oil in diethyl ether. The carrier gas was helium at 1 mL/min.

GC-MS – GC-MS was carried out using an Agilent 5973 GC-MS coupled to an Agilent 6890 gas chromatograph fitted with a split-splitless injector at 250 °C (Splitless mode). The analytical conditions have been fixed as follows: Agilent HP-5MS capillary column (30 m × 0.25 mm, $df = 0.25 \mu\text{m}$), temperature program: from 40 - 250 °C at 6 °C/min. The carrier gas was helium at 1 mL/min. The mass spectra have been recorded in EI mode at 70 eV, (scanned mass range: 35 to 500 amu). The source and quadrupole temperatures were fixed at 230 °C and 150 °C, respectively. The identification of the components was performed on the basis of chromatographic retention indices (RI) and by comparison of the recorded spectra with a computed data library (Wiley 275.L). For sesquiterpene hydrocarbons, further confirmations were obtained by comparing the mass spectra with data from the literature.¹³⁻¹⁴ RI values were measured on an HP-5MS column. RI calculations were performed in temperature programming mode according to Babushok, V et al,¹⁵ a mixture of homologues n-alkanes ($C_7 - C_{30}$) was used, under the same chromatographic conditions. Main components have been confirmed by comparison of their retention data with co-injected pure (commercially available) references.

Statistical analysis – The analysis of results was performed with statistical and graphical analysis software Minitab 17 (trial version). This statistical software was used for regression analysis of the obtained data and to estimate the coefficient of regression equation. ANOVA (analysis of variance), which is the statistical testing of the

Table 1. Codes and levels of independent variables used in the experimental design

Independent variables	Symbols	Coded levels	
		Low (-1)	High (+1)
Temperature (°C)	X_1	140	220
Mass (g)	X_2	100	250
Volume (L)	X_3	2	4.5

Table 2. Experimental matrix

Run	Independent coded variables			Yield	
	X1	X2	X3	Exp (%)	Cal (%)
1	-1	-1	-1	0.81	0.791
2	1	-1	-1	0.73	0,748
3	-1	1	-1	1.48	1.498
4	1	1	-1	1.27	1.251
5	-1	-1	1	0.94	0.958
6	1	-1	1	0.89	0.871
7	-1	1	1	1.69	1.671
8	1	1	1	1.36	1.378

Table 3. ANOVA of the fitted model

Factors (coded)	Statistics								
	Effect	Standard error	Sum of squares	DF	Mean squares	F-value	t ^a	p ^b	Remark
a ₀	1.1463	0.0187					61.13	0.01	significant
a ₁	-0.0837	0.0187	0.0561	1	0.0561	19.95	4.47	0.14	
a ₂	0.3037	0.0187	0.7381	1	0.7381	262.44	-16.2	0.039	signifucant
a ₃	0.0737	0.0187	0.0435	1	0.0435	15.47	-3.93	0.158	
a ₁₂	-0.0512	0.0187	0.0210	1	0.0210	7.47	-2.73	0.223	
a ₁₃	-0.0112	0.0187	0.0010	1	0.0010	0.36	-0.6	0.656	
a ₂₃	-0.0013	0.0187	0,0001	1	0,0001	0.00	0.07	0.958	
Pure error			0.0028	1	0.0028				
Total			0.8625	7					

R² = 99.67%

Adjusted R² = 97.72%

DF : Degree of freedom

^a: Value of the coefficient of regression for the error, measures it how big the effect is regarding the mistake standard or residue.

^b: Probability of significance. If the level of confidence is 95%, P < 0.05 considered to be significant.

model in the form of a linear term and an interaction term, was also used to test the significance of each term in the equation and the fitness of the obtained regression model.¹⁶

Result and Discussion

The oil extraction yield was simply calculated as the ration of the extracted oil mass per the initial dry mass of plant material. The response values (oil yield) with different combinations of the three variables used in our experimental design are given in Table 2, which shows considerable variation in oil yield depending on the extraction conditions.

Experimental design – The proposed models were studied by varying different parameters. The following discussion is based on the models fit for different parameters. The constants of different models were determined by minimizing the error between the experimental and calculated value.

The quadratic model equation for predicting the response function (essential oil yield) was expressed by the following first-order polynomial equation, in term of the coded factors

$$R = 1.1463 - 0.0738X_1 + 0.3037X_2 + 0.0737X_3 - 0.0512X_1X_2 - 0.0112X_1X_3 - 0.0013X_2X_3 \quad (3)$$

The study of the effect of different factors on the response was performed using the analysis design procedure of the Minitab 17. The main effects of the three variables studied and interaction effect involving these factors are shown in Table 3. The value of the constant was found to be 1.1436, which does not depend on any factor or factor interaction. A positive sign of the coefficient represents a synergistic, while a negative sign indicates an antagonist effect.¹²

In order to study the interaction effects between the variables (the heating temperature, the mass of the plant material and the volume of water), the 2D contour curves

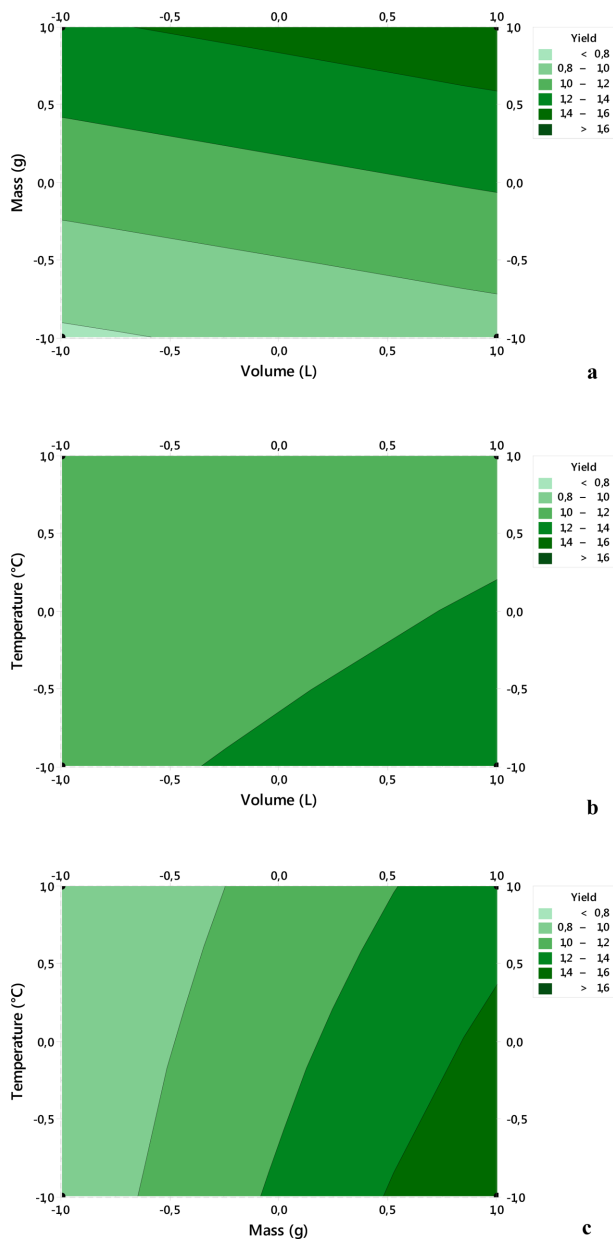

Fig. 2. Interaction effects of parameters on the essential oil yield using the 2D contours: (a): mass and volume, (b) temperature and volume, (c) Temperature and mass.

based on the quadratic model were plotted, as shown in Fig. 2. (a, b, c). As illustrated in those figures, the oil yield was significantly affected by the mass and volume. It could be seen that the essential oil yield increased by increasing of volume water and vegetable mass and decreased by increasing the heating temperature within the experimental range.

The regression results obtained from complete factorial design model are given in Table 3, where t and P values, along with the constant and coefficients, are mentioned.

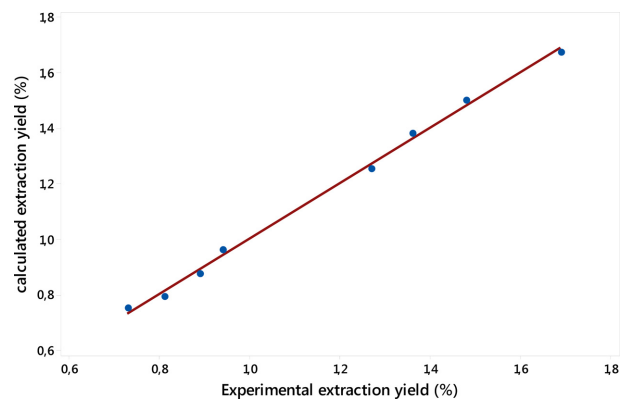

Fig. 3. Comparison between calculated and experimental yields.

The t values are used to determine the significance of the regression coefficients of the parameters and P values are defined as the smallest level of significance leading to rejection of the null hypothesis. In general, the larger magnitude of t and smaller value of P , the more significant is the corresponding coefficient term.¹⁷

The mass of plant material factor was found to be significant ($P = 0.039$) compared to the volume and temperature ($P = 1.158$ and 0.14 respectively). All other interaction were found to be insignificant ($P > 0.05$). The goodness of fit of the model was validated by determination of the coefficient (R^2). The R^2 values provide a measure of how much variability in the observed response values can be explained by the experimental factors and their interaction. High R^2 values show high significance of the model.¹²

Furthermore, the regression coefficient is estimated to be acceptable ($R^2 = 99.67\%$). The value gives good agreement between the experimental and predicted values of the fitted model. Also, a high correlation between the experimental and calculated of *T. fontanesii* essential oil yield (%) shown in Fig. 3. indicates their low discrepancies.

Optimization of operating conditions – The experimental design was used to determine the values of the three independent variables that result in a maximum *T. fontanesii* essential oil yield. The optimization of experimental conditions was carried out by maximizing the percent of oil yield at defined optimization criteria for the factors. Therefore, the optimum operating conditions were found using the numerical technique built into the Minitab 17, according to the predicted model. The optimum values to achieve the maximum yield of 1.69% after 45 min were 250 g of plant material and 4.5 L of distilled water heating at 140 °C.

Chemical composition of essential oil – The results of chemical composition of *T. fontanesii* essential oil are

Table 4. Chemical composition of *T. fontanesii* essential oil

N°	Compound name	IR							
		Exp 1	Exp 2	Exp 3	Exp 4	Exp 5	Exp 6	Exp 7	Exp 8
1	α -Thujene	2 ± 0.06	-	1.5 ± 0.011	1.63 ± 0.008	0.92 ± 0.004	0.8 ± 0.009	-	0.28 ± 0.003
2	α -Pinene	2.45 ± 0.07	1.04 ± 0.01	2.07 ± 0.01	1.8 ± 0.01	1.6 ± 0.01	1 ± 0.1	0.14 ± 0.004	1.67 ± 0.025
3	Camphene	0.15 ± 0.003	1.4 ± 0.02	0.11 ± 0.0005	0.12 ± 0.0008	0.1 ± 0.0003	0.1 ± 0.001	-	-
4	β -Pinene	0.35 ± 0.02	-	0.21 ± 0.008	0.21 ± 0.004	0.32 ± 0.001	0.3 ± 0.002	-	-
5	β -Myrcene	2.2 ± 0.04	0.27 ± 0.0007	1.77 ± 0.018	0.81 ± 0.01	1.4 ± 0.006	1.5 ± 0.1	0.24 ± 0.0005	1.05 ± 0.007
6	α -Phellandrene	0.24 ± 0.004	1.6 ± 0.1	0.18 ± 0.0003	0.22 ± 0.0005	0.18 ± 0.0004	0.2 ± 0.002	-	0.13 ± 0.004
7	α -Terpinene	1.75 ± 0.2	0.75 ± 0.06	1.32 ± 0.008	1.74 ± 0.007	1.53 ± 0.006	1.6 ± 0.1	0.32 ± 0.0094	1.08 ± 0.01
8	p-cymene	7.17 ± 0.1	1.64 ± 0.02	4.9 ± 0.22	4.6 ± 0.02	9.01 ± 0.03	6.9 ± 0.6	8.2 ± 0.2	13.1 ± 0.1
9	Limonene	0.8 ± 0.008	0.51 ± 0.1	0.6 ± 0.006	0.6 ± 0.02	0.66 ± 0.0034	0.6 ± 0.008	0.34 ± 0.01	0.9 ± 0.01
10	γ -Terpinene	11.8 ± 0.13	10.2 ± 0.08	10.4 ± 0.034	11.9 ± 0.04	10.3 ± 0.02	11.5 ± 0.1	2.45 ± 0.06	7.78 ± 0.06
11	β -Terpineol, cis	0.08 ± 0.001	0.34 ± 0.01	-	-	-	0.2 ± 0.0001	-	0.12 ± 0.003
12	trans-Sabinene hydrate	1024	-	-	-	0.13 ± 0.006	0.11 ± 0.01	-	-
13	α -Terpinolene	1092	0.14 ± 0.009	-	-	0.09 ± 0.0005	tr	tr	0.11 ± 0.005
14	Linalool	1101.6	2.65 ± 0.01	2.23 ± 0.001	2.1 ± 0.003	2.7 ± 0.02	0.1 ± 0.001	3.07 ± 0.08	2.33 ± 0.15
15	Borneol	1174	0.17 ± 0.004	0.33 ± 0.02	0.57 ± 0.034	0.16 ± 0.005	3.5 ± 0.003	0.21 ± 0.006	0.2 ± 0.03
16	Terpinen-4-ol	1184.4	0.63 ± 0.1	0.67 ± 0.01	-	0.36 ± 0.01	0.3 ± 0.001	0.32 ± 0.05	-
17	Carvacrol, methyl ether	1248.1	0.51 ± 0.005	0.75 ± 0.001	0.37 ± 0.025	0.5 ± 0.0009	0.7 ± 0.00	0.12 ± 0.006	0.33 ± 0.0001
18	Thymol	1293.9	3.9 ± 0.14	4.05 ± 0.01	3.05 ± 0.6	3.4 ± 0.18	4.5 ± 0.005	1.02 ± 0.034	0.9 ± 0.009
19	Carvacrol	1313.6	61.27 ± 0.34	55.9 ± 0.09	68.7 ± 0.25	66.7 ± 0.54	61.7 ± 0.1	70.6 ± 0.11	66.3 ± 0.6
20	α -Gurjunene	1425.9	0.12 ± 0.01	0.14 ± 0.0002	0.13 ± 0.00015	0.18 ± 0.0004	0.21 ± 0.001	0.1 ± 0.0006	0.35 ± 0.04
21	Caryophyllene	1437.4	0.14 ± 0.03	0.4 ± 0.002	0.14 ± 0.002	0.2 ± 0.0006	0.25 ± 0.0006	0.2 ± 0.0001	0.16 ± 0.002
22	Alloaromadendrene	1457	-	-	-	tr	0.1 ± 0.001	0.11 ± 0.0007	-
23	α -Caryophyllene	1500	-	-	-	-	-	4.22 ± 0.11	-
24	Butyl Hydroxy Toluene	1521	0.33 ± 0.004	-	-	0.35 ± 0.001	0.4 ± 0.01	0.38 ± 0.009	-
25	α -Amorphene	1530	-	-	0.24 ± 0.0007	-	-	0.31 ± 0.01	-
26	δ -Cadinene	1536.9	-	-	-	-	0.1 ± 0.0009	0.44 ± 0.007	-
27	spathulenol	1597.9	0.22 ± 0.004	0.28 ± 0.3	0.27 ± 0.03	0.19 ± 0.001	0.4 ± 0.001	0.31 ± 0.007	0.3 ± 0.002
28	Caryophyllene oxide	1600	-	-	0.06 ± 0.0008	-	-	0.14 ± 0.003	0.15 ± 0.001
29	α -Cadinol	1662.3	-	-	-	-	0.2 ± 0.0002	-	-
	Monoterpenes (%):	29	16.29	23.06	23.63	26.24	24.81	11.7	26.22
	Oxygenated monoterpenes (%):	69.13	67.9	74.92	73.22	62.9	70.8	75.34	70.06
	Sesquiterpenes (%):	0.6	0.54	0.51	0.73	0.86	0.5	6.72	0.51
	Oxygenated sesquiterpenes (%):	0.22	0.28	0.33	0.12	0.19	0.4	0.45	0.45
	Identified compounds (%):	98.95	85.01	98.82	97.7	90.19	96.51	94.21	97.24

RP^b: Retention indices relative to C₇ – C₃₀ on the HP-5MS capillary column
tr: traces (<0.1%)

reported in Table 4. Twenty nine compounds were identified in the total of the oil extracted. A substantially higher amount of oxygenated monoterpenes (62.9 – 75.3%) were found to be present in the oil compared to monoterpenes (11.7 – 29%) with a lower amount of the sesquiterpenes (0.5 – 6.7%). In all experiments, carvacrol was the main component, followed by p-cymene and γ -terpinene.

These results are in agreement with those of other essential oils of *T. fontanesii* from Algeria,¹⁸⁻²¹ who reported the following major components: carvacrol (54.7 – 69.5%), p-cymene (6.1 – 9.1%) and γ -terpinene (5.8 – 9.6%). Similar analysis of Algerian *T. fontanesii* essential oil was presented by a thymol (67.8%) as a main compound followed by p-cymene (13%) and γ -terpinene (15.9%), with a low proportion of carvacrol (1.7%).⁸ The difference among chemical composition of the essential oils widely depends on production conditions such as, variety and cultivar factors.²² However, the relative amounts differ in experiments due to a change in operating conditions, (Temperature of heating, mass of plant material and volume of water), where, the increase in the mass of plant material and volume of water increasing the amount of carvacrol, on the other hand the increasing in the heating temperature decreasing the amount of carvacrol. Therefore, the highest yield value of 1.69% obtained in the present work at 140 °C, 250 g and 4.5 L is corresponding to the highest amount of carvacrol detected ($70.6 \pm 0.11\%$). The eight samples of essential oil analyzed presented a variety in their composition; a lot of components were common for different samples, whereas other components were found just in some samples. For example, trans-sabinene hydrate, alloaromadendrene, α -caryophyllene, α -amorphene, α -cadinol. Hence, there is a variation in the composition and yield. The sample of Exp 7 was distinguished by the highest amount of oxygenated monoterpene (75.34%), sesquiterpene (6.72%) and oxygenated sesquiterpene (0.45%) and by the lowest amount of monoterpene (11.7%), which was obtained by extracting the high amount of plant (250 g) with high volume of water (4.5 L), heating under the lowest temperature (140 °C). On comparison between the Exp 7 and the Exp 1 and between the Exp 1 and the Exp 2, the mass of plant and the volume of water affect inversely on the amount of monoterpene. On the Exp 7 and Exp 8, the temperature of heating is also affect inversely the amount of oxygenated sesquiterpenes.

The decrease in mass of plant is more influence on amount of oxygenated monoterpenes and oxygenated sesquiterpenes than the volume of water. The opposite on

the amount of monoterpenes and sesquiterpenes where the volume of water is the more affect, as shown in Exp 7 and Exp 5. The different experiments showed that the variation in chemical composition of *T. fontanesii* essential oil was more dependent by the mass of plant.

Here, a try is made to understand the probable reasons, which have led to such differences considering the difference between the operation conditions of experience 1 to experience 8.

Under the obtained optimal conditions represented by the Exp 7 (T = 140 °C, m = 250 g and V = 4.5 L), GC-MS and GC-FID analysis revealed the presence of the higher amount of carvacrol ($70.6 \pm 0.1\%$), followed by p-cymene ($8.2 \pm 0.2\%$), linalool ($3.07 \pm 0.08\%$) and γ -terpinene ($2.34 \pm 0.06\%$). The statistical method employed is advantageous not only to increase the yield of essential oil but also to improve the quality of the oil.²³

Conclusion

In the present study, we optimized the operative conditions on *T. fontanesii* essential oil yield obtained by the electromagnetic induction heating assisted extraction using the methodology of experimental design that aims the obtain maximum results for a smaller number of experiments. Three-factors, two levels were applied to establish a first-order model considering the heating temperature, the mass of plant material and the water volume as independent variables. The predicted results from the response functions were in good agreement with the experimental data ($R^2 = 99.67\%$), confirming the reliability of the employed methodology.

The optimum essential oil yield of *T. fontanesii* (1.69%) was found after 45 min under the operating conditions: 250 g of plant material and 4.5 L of water heating at 140 °C, based on the developed quadratic model. Analyzing the variance (ANOVA) showed that the model is significant and can adequately describe the experimental range. The chemical composition of the Algerian *T. fontanesii* essential oil under the obtained optimal conditions (140 °C, 250 g and 4.5 L), determined by GC/MS and GC/FID, revealed of the presence of major components such as: carvacrol ($70.6 \pm 0.1\%$), followed by p-cymene ($8.2 \pm 0.2\%$). The results clearly showed that the experimental design is a suitable method to optimize the *T. fontanesii* essential oil extraction by EMI heating operating conditions.

The electromagnetic induction heating assisted extraction is an innovative method for obtained the essential oils, in order to increase the quantity and to preserve the quality

of the oil, with a short extraction time compared to other conventional equipment such as the hydrodistillation. This efficiency is probably based on the interaction between the rapidity of heating by electromagnetic induction and the evaporation of essential oil components. The EMI heating is able to satisfy the quality requirements of the pharmaceutical and food industry.

References

- (1) Morales, R.; Stahl-Biskup, E.; Sáez, F. The history, botany and taxonomy of the genus *Thymus*. *Thyme: the genus Thymus; Medicinal and Aromatic Plants*; Taylor and Francis: U. K, **2002**, pp 1-43.
- (2) Nabavi, S. M.; Marchese, A.; Izadi, M.; Curti, V.; Daglia, M.; Nabavi, S. F. *Food Chem.* **2015**, *173*, 339-347.
- (3) Barros, L.; Heleno, S. A.; Carvalho, A. M.; Ferreira, I. C. *LWT-Food Sci. Technol.* **2010**, *43*, 544-550.
- (4) Zarzuelo, A.; Crespo, E. The medicinal and non-medicinal uses of thyme. In *Thyme: the genus Thymus*, CRC Press: **2002**.
- (5) Mann, J. *Phytochemistry* **1998**, *48*, 585.
- (6) Casiglia, S.; Bruno, M.; Scandolera, E.; Senatore, F. *Arab. J. Chem.* In Press, **2015**.
- (7) Stahl-Biskup, E.; Sáez, F. *Thyme: the genus Thymus; Medicinal and Aromatic Plants*; Taylor and Francis: London, **2002**.
- (8) Ghannadi, A.; Sajjadi, S. E.; Kabouche, A. Z. *Naturforsch. C.* **2004**, *59*, 187-189.
- (9) Starmans, D. A.; Nijhuis, H. H. *Trends Food Sci. Technol.* **1996**, *7*, 191-197.
- (10) Wang, L.; Weller, C. L. *Trends Food Sci. Technol.* **2006**, *17*, 300-312.
- (11) El Asbahani, A.; Miladi, K.; Badri, W.; Sala, M.; Ait Addi, E. H.; Casabianca, H.; El Mousadik, A.; Hartmann, D.; Jilale, A.; Renaud, F. N. R.; Elaissari, A. *Int. J. Pharm.* **2015**, *483*, 220-243.
- (12) Ammar, A. H.; Zagrouba, F.; Romdhane, M. *Flavour Frag. J.* **2010**, *25*, 503-507.
- (13) Adams, R. P. *Quadrupole mass spectra of compounds listed in order of their retention time on DB-5. Identification of essential oils components by gas chromatography:quadrupole mass spectroscopy*; Allured Publishing Corporation: USA, **2001**, 3rd ed.
- (14) Joulain, D.; König, W. A. J. *The Atlas of Spectral Data of Sesquiterpene Hydrocarbons*. E.B. – Verlag Hambourg, *J. Nat. Prod.*, **1999**, *62(8)*, 1212-1213.
- (15) Babushok, V. I.; Linstrom, P. J.; Zenkevich, I. G. *J. Phys. Chem. Ref. Data* **2011**, *40*, 043101.
- (16) Huiping, L.; Guoqun, Z.; Shanting, N.; Yiguo, L. *Comput. Mater. Sci.* **2007**, *38*, 561-570.
- (17) Ravikumar, K.; Krishnan, S.; Ramalingam, S.; Balu, K. *Dyes Pigm.* **2007**, *72*, 66-74.
- (18) Bekhechi, C.; Bekkara, F. A.; Abdelouahid, D. E.; Tomi, F.; Casanova, J. J. *J. Essent. Oil Res.* **2007**, *19*, 594-596.
- (19) Sidali, L.; Brada, M.; Fauconnier, M. L.; Lognay, G.; Heuskin, S. *PhytoChem Biosub J.* **2017**, *11*, 11.
- (20) Mouhi, L.; Moghrani, H.; Nasrallah, N.; Amrane, A.; Maachi, R. *J. Food Biochem.* **2017**, *41*, 1-9.
- (21) Dob, T.; Dahmane, D.; Benabdelkader, T.; Chelghoum, C. *Pharm. Biol.* **2006**, *44*, 607-612.
- (22) Bailer, J.; Aichinger, T.; Hackl, G.; de Hueber, K.; Dachler, M. *Ind. Crops Prod.* **2001**, *14*, 229-239.
- (23) Desai, M. A.; Parikh, J.; De, A. K. Modelling and optimization studies on extraction of lemongrass oil from *Cymbopogon flexuosus* (Steud.) Wats. *Chem. Eng. Res. Des.* **2014**, *92*, 793-803.

Received November 21, 2017

Revised January 12, 2018

Accepted January 12, 2018