



## Original article

# Association Between Social Support, and Depressive Symptoms Among Firefighters: The Mediating Role of Negative Coping

Liang Wang<sup>1,☆</sup>, Fengqiong Chen<sup>2,☆</sup>, Yulu Zhang<sup>1</sup>, Mengliang Ye<sup>1,\*</sup>

<sup>1</sup> College of Public Health, Chongqing Medical University, China

<sup>2</sup> Chongqing Center for Disease Control and Prevention, China

## ARTICLE INFO

## Article history:

Received 4 June 2023

Received in revised form

12 September 2023

Accepted 3 October 2023

Available online 5 October 2023

## Keywords:

depressive symptoms

firefighters

negative coping

social support

structural equation modeling

## ABSTRACT

**Background:** Depressive symptoms (DS) can erode physical and mental health; social support (SS) is considered a buffer for DS and a promoter for improving coping and recovery abilities. However, there is almost no research on the mediating role of negative coping (NC) in SS and DS, especially among firefighters.

**Methods:** A cross-sectional survey was conducted among firefighters in Chongqing, China, and the valid data of 407 firefighters were collected through questionnaires distributed on the WeChat platform in 2020. Statistical Product and Service Solutions (SPSS) 26.0 is used for descriptive statistics and correlation analysis. Structural equation modeling was adopted to analyze the association among SS, NC, and DS. The mediation effect is also evaluated.

**Results:** Firefighters' detection rate of DS is 23.3%, and when they receive more SS were less likely to develop DS. NC was positively correlated with DS ( $\beta = 0.54, p < 0.001$ ) after controlling for SS. Besides, the results of structural equation modeling showed that NC partially mediates the relationship between SS and DS (standard error = 0.039, indirect effects = 0.109, 95% confidence interval: 0.047–0.200  $p < 0.001$ ).

**Conclusion:** NC has a partial indirect effect between SS and DS among firefighters. SS could not only affect DS directly but also indirect work on it by affecting NC. This discovery will be a novel and meaningful part of the research on the firefighter population.

© 2023 The Authors. Published by Elsevier B.V. on behalf of Occupational Safety and Health Research Institute, Korea Occupational Safety and Health Agency. This is an open access article under the CC BY-NC-ND license (<http://creativecommons.org/licenses/by-nc-nd/4.0/>).

## 1. Introduction

According to the World Health Organization, depression and other mental health conditions are on the rise worldwide and remain a threat to public health, of which the most significant increases in depression and anxiety. Depression is regarded as the second-leading cause of disability in China [1], and its prevalence is increasing rapidly with China's economic growth and social changes [2]. As a special high-risk profession, firefighters not only need to face risks and deal with emergency situations but also need to undergo high-intensity training, which contributes to psychological problems, such as post-traumatic stress disorder and depression [3]. A study indicated that the firefighters' work appears

to be a strong source of stress and mental strain [4], which contribute to greater risk of mental and physical health problems [5]. It is estimated that the prevalence rate of depression among firefighters reached 22% [3].

Firefighters is a high-risk profession with exposure to traumatic events and heavy work stress [6], are the population with a high prevalence of depressive symptoms (DS). A systematic review suggests that their mean prevalence of depression is 18.7%, which is higher than those of the community population [7]. Because of the busy routine and intensive workload, the prevalence of DS among Chinese firefighters has reached 22.68% [8]. One study in the United States found that 27% of firefighters suffered from major depression after participating in a rescue [9]. Firefighters is also a male-

Liang Wang: <https://orcid.org/0009-0006-6071-4920>; Fengqiong Chen: <https://orcid.org/0000-0002-2572-3796>; Yulu Zhang: <https://orcid.org/0009-0004-4194-8209>; Mengliang Ye: <https://orcid.org/0009-0002-3777-9954>

\* Corresponding author. College of Public Health, Chongqing Medical University, 400016, China.

E-mail address: [yemengliang@cqmu.edu.cn](mailto:yemengliang@cqmu.edu.cn) (M. Ye).

☆ These authors contributed equally to this work.

dominated profession, according to the estimation of International Association of Fire and Rescue Services, only about 9% of all firefighters worldwide are female [10]. Besides, the population of firefighters has a wide age range, a study in the United States has found that almost all America firefighters sent to the front line are between the ages of 20 and 59 [11]. However, numerous highlights have focused on the depression in high-stress occupations such as teachers, doctors, and nurses; the DS in the high-risk profession of firefighters have received a little attention, especially when the negative coping (NC) as a mediate role. Thus, this deserves further study.

The early state of depression is DS. DS include low mood, reduced enjoyment, increased fatigue, hopelessness and sleep difficulties, which often persist or fluctuate, and a large proportion of patients do not respond to standard treatment [12]. Several studies have shown that younger adults and people with greater social strain or less social support (SS) have worse mental health and that perceived SS influences the overall outcome of depression, which plays a key role in recovery from affective disorders [13–15]. Firefighters' mental health such as DS is affected in many ways, SS and coping strategies have been proven to be protective factors for mental health in previous studies [16–18]. In fact, individuals with limited social networks have a higher risk of depression [19]. Therefore, SS plays a crucial role in the occurrence of DS.

The definition of SS is the practical assistance, emotional support, and information assistance provided to individuals by meaningful groups around them, such as family members, friends, colleagues, relatives, neighbors, and so on, when they are in a difficult situation [20], and it is often broadly defined as providing help, comfort, or resources to individuals to help them cope with stressors [21]. SS can be divided into several specific types: instrumental; emotional; informational; companionship; appraisal support, which is considered a buffer for stress and a promoter for improving coping and recovery abilities [22,23]. Support from peers, colleagues, family, and friends has also been shown to help individuals sustain emotional balance in the face of threats and stress-inducing events [24]. Some previous studies demonstrated that SS relates to psychological well-being positively [25,26], when people with higher levels of SS have a 63% lower risk of DS [27], so SS can protect against DS and psychological distress [28–30]. Thus, adequate SS can provide a safe environment to talk about negative experiences, thereby reducing DS [31].

Coping is "a constantly changing cognitive and behavioral effort to manage specific external or internal needs that are assessed as consuming or exceeding the resources of the individual" and includes both positive and NC [32]. NC and positive coping are two completely opposite ways of coping. Individuals who primarily adopt positive coping strategies experience less emotional distress, while individuals who adopt NC strategies experience the opposite [33]. In addition, positive coping styles and family support are protective factors, while NC styles can exacerbate psychological problems [34]. Therefore, the coping style they choose is of the utmost importance when people face difficult or complex negative events, which will affect their psychosocial outcomes, especially for their mental health. It is important to note that SS is a psychological and material resource provided by a social network [35], when people face pressure and difficulties, SS is a strong backing, which can enhance the confidence to cope with setbacks and influence the choice of coping style. Research has shown that SS can reduce stress and the impact of stressful situations, prepare individuals for difficult situations, and improve their ability to cope [36], so there is a strong correlation between SS and NC.

Although the above studies have explored the link between SS and mental health, the effect mechanism by which SS affects DS remains to be analyzed, especially when NC acts as a mediator. Structural equation modeling (SEM) is widely used to verify complex phenomena, involving various themes, such as humans, health, and the environment, which provides an extensive toolbox for analyzing the multivariate interrelationships between directly observed variables and underlying structures [37]. Therefore, SEM is a very appropriate method to verify the mediating effect of NC between SS and DS. Besides, there exists limited research on the relationship between SS, NC, and DS among firefighters, so it is meaningful to explore the mechanism by which SS influences DS through NC.

In the current study, our aims were threefold. First and foremost, to testify whether the higher SS scores, the less likely to have DS among firefighters. Second, to research if firefighters with higher NC scores were more likely to have DS. Third, to examine the mediating effect of NC on SS and DS.

## 2. Materials and methods

### 2.1. Participants and process

A cross-sectional survey was conducted in 2020 among firefighters in Chongqing, the largest economic center in southwest China. This study included a sample of 407 firefighters with an average age of 29.12(S.D. = 5.86). We selected firefighters through random sampling and distribute questionnaires to them. A total of 450 questionnaires were issued and 423 were collected, including 16 with missing values and outliers. The recovery rate was 94% and the effective rate was 96.22%. Then remaining 407 copies are valid. We analyze the collected data through cross-sectional research and use qualitative surveys as a supplement to quantitative surveys. The subjects also met the following inclusion criteria: ① Voluntarily participated in the survey and sign informed consent, ② no history of mental illness and did not take any psychotropic drugs, ③ the working time is more than half a year in this position; exclusion criteria: ① refused to participate in the survey, ② less than half a year of service, ③ long-term sick leave or resignation, ④ recent use of psychotropic drugs.

### 2.2. Measurement

#### 2.2.1. Basic demographic investigation

Table 1 presents the full descriptive statistical results of the sample characteristics. The number of male firefighters is much higher than female ones (96.3% vs. 3.7%). More than two-thirds (83.0%) of the firefighters had attended high school to junior college, and most of them are unmarried (67.1%). The individuals participated in this survey were required to complete and authentic information, which include gender, age, educational level, marital status, and so on. Age will be regarded as control variables in the following studies.

#### 2.2.2. Depressive symptoms

DS were measured by translated Patient Health Questionnaire, which is composed of 9 items, and it is can be summarized as 9 different aspects: interest, mood, sleep, fatigue, appetite, failure, attention, action, and suicide. It has been proven to be very effective and reliable in the Chinese population [38]. It assessed the frequency of symptoms in the past two weeks: "never", "occasionally", "more than a half", "all the time". Each item is assigned Likert 4 points, "never" (0 point), "occasionally" (1 point), "more than a

**Table 1**  
Comparison of DS, SS, and NC under different demographic and sociological characteristics

Category	Frequency (n)	Constituent ratio (%)	DS		SS (M ± SD)	NC (M ± SD)			
			Yes(%)	No(%)					
1 Gender(n = 407)									
Male	392	96.3	89 (22.7)	303 (77.3)	2.415	9.0 ± 4.0	3.133	23.6 ± 7.5	6.533*
Female	15	3.7	6 (40.0)	9 (60.0)		10.9 ± 3.6		28.7 ± 7.0	
2 Educational level									
Junior high school and below	12	3.0	2 (16.7)	10 (83.3)		8.6 ± 3.0		26.4 ± 7.9	
High school to junior college	338	83.0	75 (22.2)	263 (77.8)	2.711	9.0 ± 4.1	0.618	23.3 ± 7.7	3.583*
Bachelor degree or above	57	14.0	18 (31.6)	39 (68.4)		9.6 ± 3.7		25.9 ± 6.1	0.685
3 Marital status									
Unmarried	273	67.1	56 (20.5)	217 (79.5)	8.014*	8.9 ± 3.9		23.8 ± 7.5	
Married	115	28.3	31 (27.0)	84 (73.0)		9.4 ± 3.9	1.478	23.7 ± 7.9	0.025
Divorced/widowed	19	4.6	8 (42.1)	11 (57.9)		10.2 ± 5.2		24.1 ± 7.1	
4 Age									
≤ 25years	103	25.3	17 (18.7)	74 (81.3)		8.3 ± 3.6		24.2 ± 8.3	
25 < y < 35years	257	63.1	64 (24.2)	201 (75.8)	1.869	9.3 ± 4.0		23.4 ± 7.3	
35 ≤ y ≤ 45years	34	8.4	11 (28.9)	27 (71.1)		9.4 ± 4.4	1.894	25.0 ± 7.4	0.635
≥ 46years	13	3.2	3 (23.1)	10 (76.9)		10.0 ± 5.3		24.5 ± 7.9	
Total	407	100	95 (23.3)	312 (76.7)		9.1 ± 4.0		23.8 ± 7.6	

Note: DS, depressive symptoms; NC, negative coping; SS, social support, \* $p < 0.05$ .

half" (2 points), "all the time" (3 points), and when total scores more than 10 points is considered DS. Besides, the score is higher, the more severe the DS are, and the Cronbach's alpha for this component in this study was 0.927.

### 2.2.3. Social support

SS was measured by the scale developed by the project team to evaluate the stress of the survey subjects. It is a new assessment method established by the National Institute of Occupational Health and Poisoning Control for occupational populations in China [39]. This scale consisted of 5 items, which can be expressed as support from leader, colleague, unit, favor and family, each item is assigned Likert 5 points, "completely disagree" (1 point), "disagree" (2 points), "basically agree" (3 points), "agree" (4 points), "strongly agree" (5 points), these items were reversely scored (6 - actual score), then the scores of each item and the total score were calculated. The higher the scores, the lesser the SS. The Cronbach's alpha of this scale was 0.932.

### 2.2.4. Negative coping

In this part, the Trait Coping Style Questionnaire compiled by Qianjin Jiang was used to evaluate the relatively stable coping style of individuals with certain personality tendencies to different events in life, it is concluding two coping strategies: positive coping and NC [40]. NC includes 10 items: memory, anger, fluctuation, press, cry, ignore, hesitate, unhappy, blame, and solitude. Accumulate points by items, and the higher the score, the level of NC is higher. Moreover, this scale's Cronbach's alpha is 0.909. The reliability and validity levels of each scale are shown in Table 2.

### 2.3. Statistical analysis

After removing missing values and outliers, 407 sets of valid data were left, then Statistical Product and Service Solutions (SPSS) 26.0 was used for data analysis, such as Pearson correlation

**Table 2**  
Reliability and validity test of SS, DS, and NC Scales

	Cronbach's alpha	KMO	p value	Number of items
SS	0.932	0.892	<0.001	5
DS	0.927	0.936	<0.001	9
NC	0.909	0.939	<0.001	10

Note: DS, depressive symptoms; SS, social support; NC, negative coping.

analysis, one-way analysis of variance, and normality tests. We use Chi-square test and independent sample t-test to examine difference in different variable. We used AMOS 24.0 to construct SEM and tested the mediation effects. The test level in this study was  $\alpha = 0.05$ .

## 3. Results

### 3.1. Descriptive statistics and sample characteristics

In this sample, there are more male than female firefighters, occupied 96.3% (392) and 3.7% (15), respectively, and their DS detection rates were 22.7% and 40% severely, and the total detection rate is 23.3%, the difference was significant between different marital status ( $\chi^2 = 8.014, p < 0.05$ ) in DS. The scores for SS and NC are (9.0 ± 4.0; 10.9 ± 3.6), (23.6 ± 7.5; 28.7 ± 7.0), and the difference was not statistically significant between males and females ( $t = 3.133, p > 0.05$ ) in SS. However, there was statistically significant difference between males and females ( $t = 6.533, p < 0.05$ ) and educational level ( $t = 3.583, p < 0.05$ ) in NC. There is no significant difference in overall average scores for SS and NC between marital status and age. Most of their education background is high school to junior college, occupied 83%. A large proportion of firefighters are unmarried, which take up 67.1%. Besides, firefighters are always young, 88.4% are under the age of 35. More information can be found in Table 1.

### 3.2. Correlation analysis

Table 3 showed the result of Pearson correlation analysis, which indicated that SS of has positive relationship with DS ( $r = 0.127, p < 0.05$ ), and NC positively correlated with DS ( $r = 0.566, p < 0.01$ ). SS has positively correlation with NC ( $r = 0.130, p < 0.01$ ) among firefighters.

**Table 3**  
Pearson correlation analysis among SS, DS, and NC

Variable	DS	SS	NC
DS	1		
SS	.127*	1	
NC	.566**	.130**	1

Note: \*\* $p < 0.01$ ; \* $p < 0.05$ , DS, depressive symptoms; NC, negative coping; SS, social support.

**Table 4**  
Model fit index of SEM

Index	Reference standard	Measurement
CMIN/DF	1-3 is excellence	2.026
RMSEA	<0.08 is good	0.050
SRMR	<0.05 is good	0.046
GFI	>0.9 is good	0.900
TLI	>0.9 is good	0.953
IFI	>0.9 is good	0.958
NFI	>0.9 is good	0.920
CFI	>0.9 is good	0.957
PGFI	>0.5 is good	0.747
PNFI	>0.5 is good	0.828

Note: CMIN/DF, chi-square fit statistics/degree of freedom; RESEA, root mean squared error of approximation; SRMR, standardized root mean square residual; GFI, goodness of fit index; TLI, Tucker-Lewis index; IFI, incremental fit index; NFI, normative fit index; CFI, comparative fit index; PGFI, parsimony goodness of fit index; PNFI, parsimony normed fit index.

3.3. Model descriptions and mediating effect analysis

SEM was employed to quantify the relation between SS, NC, and DS according to the correlation analysis. In SEM, the SS regard as

the predictor variable (X), NC is the intervening variable (I), and the DS is the outcome variable (Y) (Fig. 1).

The model fit indices of the SEM have been demonstrated in Table 4. The chi-square fit statistics/degree of freedom is 2.026 (less than 3 is greater), root mean squared error of approximation (RMSEA) is 0.050 (generally, less than 0.08 is required) standardized root mean square residual = 0.046 (less than 0.05, which we consider a good model fit), incremental fit index is 0.958, normative fit index (NFI) = 0.920, Tucker-Lewis index is 0.953, comparative fit index = 0.957, goodness of fit index (GFI) is 0.900, parsimony normed fit index = 0.828, parsimony goodness of fit index = 0.747 (the criterion of parsimony normed fit index and parsimony goodness of fit index is greater than 0.50). The criterion of GFI, Tucker-Lewis index, NFI, comparative fit index, and incremental fit index is greater than 0.9 [41]. The model can be considered good because each parameter of model fit is significant.

The total effects are 0.374 (standard error (S.E.) = 0.077, 95% confidence interval (CI):0.234–0.536  $p < 0.001$ ), direct effects are 0.265 (S.E. = 0.062, 95% CI:0.154–0.398  $p < 0.001$ ), indirect effects are 0.109 (S.E. = 0.039, 95% CI:0.047–0.200  $p < 0.001$ ). Mediating effect results manifest that reverse SS scores can positively predict DS ( $\beta = 0.30, p < 0.001$ ) and NC ( $\beta = 0.23, p < 0.001$ ), NC predicted DS ( $\beta = 0.54, p < 0.001$ ) after controlling for SS positively. The

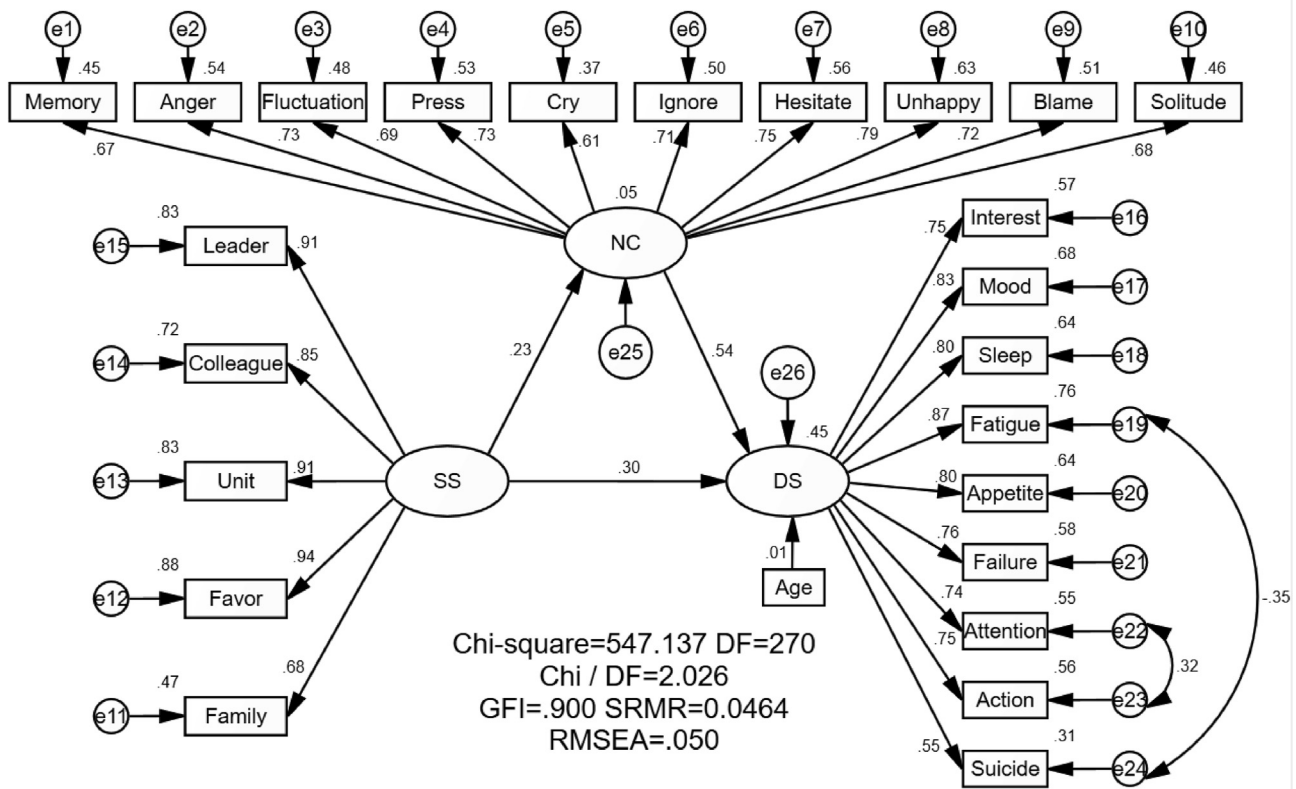

Fig. 1. The SEM of SS, DS, and NC. Note: e1 ~ e26 is residual error; DS, depressive symptoms; SS, social support; NC, negative coping; SEM, structural equation modeling.

**Table 5**  
Mediating effects of SS and DS

SS	→	DS	Effect	S.E.	P	Beta	Lower	Upper
Total effects			0.374	0.077	$p < 0.001$	0.37	0.234	0.536
Direct effects			0.265	0.062	$p < 0.001$	0.30	0.154	0.398
Indirect effects			0.109	0.039	$p < 0.001$	0.23	0.047	0.200

Note: S.E. is the standard error; Beta is the standardized path coefficient; Lower and Upper are 95% confidence interval; DS, depressive symptoms; SS, social support.



confidence interval for the mediation effect is (0.047, 0.200), if the confidence interval does not contain zero, the mediation effect is significant [42]. Thus, in this model, the mediation effect is prominent. Additionally, the equation of the mediation effect model is  $Y = 0.37X + e_1$ ,  $M = 0.23X + e_2$ , and  $Y = 0.30X + 0.54M + e_3$  ( $e_1, e_2, e_3$  are random error of three equations severally). The specific values of each effect are shown in Table 5.

#### 4. Discussion

This study analyzed the relationship between SS, NC, and DS among firefighters, we examined the direct effects of SS on DS, and the mediating effect of NC on SS and DS was also investigated. The major findings of this research were elaborated as follows.

We observed that the NC was positively associated with the DS of firefighters ( $\beta = 0.54, p < 0.001$ ), which manifested the higher the level of NC, the more likely it is to experience DS, which is consistent with many studies on different groups of people, such as pregnant woman [43,44] and lung cancer outpatients [45]. What is more, the inverse scores of SS was positively correlated with DS ( $\beta = 0.30, p < 0.001$ ), namely that the SS a firefighter receives can help them build self-esteem and reduce depression [46], a previous study on Chinese nurses also found that improve SS levels can reducing their DS [47]. SEM results indicate that the mediating effect of NC on SS and DS was significantly established, the indirect effects are 0.109 (95% CI:0.047–0.200  $p < 0.001$ ). This suggests that NC partially mediates the relationship between SS and DS.

Simultaneously, the data from the study showed that firefighters had a higher incidence of DS, reached 23.3%. It may be because firefighters often need to handle emergency situations and face enormous psychological pressure, which leads to their mental health problems [48]. SS is an important factor in this phenomenon, we found that their SS scores were not very high ( $9.0 \pm 4.0$ ), which shows that firefighters do not get enough SS. It has been widely reported that SS can be used as a predictor of DS [28], so they are more likely to have DS when they have less SS, and a study also reported that individuals who were more satisfied with their support were less likely to suffer from depression [49]. We also discovered that the proportion of DS varies among different marital states, married people have lower DS ratio than unmarried people, since they are more likely to get SS from their spouses and families, lead to the decrease of their DS proportion. Some studies even suggested that married people tend to be healthier on both mental and physical than non-married people [50]. Besides, NC styles are also significant between gender and educational level, when it comes to coping and gender differences, previous studies have shown that in the non-clinical population, men mainly use problem-centered coping mechanisms and less use emotion-centered coping mechanisms/avoidance coping styles [51–53], so leads to differences in NC styles between men and women. Researchers have found that when considering the general population, it is generally believed that anxiety and depression are dominant in women compared to men [54,55], so that is why female firefighters scored higher in NC than male firefighters in this study. To sum up the outcome, the higher SS scores firefighters have, the less likely to have DS; secondly, and firefighters with higher NC scores were more likely to have DS. At this point, the first and second goals of our research have been achieved.

In recent years, exploring SS and its relationship with mental health has become one of the fields of psychological development. Previous studies have shown that SS among healthcare professionals in developed countries is associated with depression [56], and the SS can help physicians maintain a better mental health status and well-being [18]. In this research, SEM results demonstrated SS can not only directly affect DS, but also induce DS

through the mediating effect of NC. In addition, the examination of the mediating effect results was significant, and NC played a partial mediating role between SS and DS. That is to say, the SS directly or indirectly affects the development of DS [57], namely that firefighters who receive less SS would be more likely to choose NC styles, which would lead to higher possibility of DS. Thus, the results in line with our third aim.

Generally speaking, firefighters are in a state of readiness for uncertain events and hazardous situations for a long period of time, it may cause firefighters to feel worried and afraid of terrifying events [58,59], which cause psychological problems for firefighters easily, such as DS and anxiety. We believe that our results contribute to the literature by confirming and extending previous findings in several ways. Previous studies just devoted attention to the relationship between perceived SS and DS. To the best of our knowledge, little previous study has investigated the mechanisms connecting these constructs, especially when research on the mediating effect of NC between the two is not available among firefighter population. Studies have shown that higher NC scores are more likely to lead to depression [60], so this study is the first to widen the focus of the mediate effect of NC and present a more complex scenario of how SS influences DS. As a result, increasing the SS received by firefighters and reducing NC styles is of great significance for reducing the occurrence of DS in the future.

Although all the purposes of this study have been achieved, there are still some deficiencies need to improve. First, the sample size of this study is relatively small and not comprehensive, so the sample size and diversity should be increased in later studies. Second, from the perspective of data collection, the data collected in the questionnaire may be occurred arbitrary, leading to deviation, so there is room for further improvement.

#### 5. Conclusion

The aims of our study have all been achieved, namely that significant correlation between SS, NC, and DS among firefighters were discovered. In summary, the more SS a person receives, the lower their likelihood of developing DS. Conversely, when a person's SS is reduced, it can lead to NC situations, which can bring about DS. More than that we have also found that NC plays a mediating role between SS and DS, which was not available in previous studies. Related research is very scarce among firefighters. In this study, the condition of DS and SS among firefighters was not optimistic, so we can not turn a blind eye about these. On the one hand, whether it is firefighters' families or citizens, we should support them from all aspects in order to prevent the occurrence of DS from the root cause. On the other hand, firefighters themselves should actively deal with the pressure and anxiety in their work and life, so that they can have better psychological quality and a healthy life.

#### Author contributions

Each author has met the authorship requirements. M.Y. put forward ideas, F.C. collected the data, L.W. and F.C. wrote the main manuscript text. Y.Z. organized the data, and L.W. completed all data analysis. Y.Z. prepared the figures and tables. L.W. rewrote the manuscript and F.C. and Y.Z. revised it. All authors have read and agreed to the published version of the manuscript.

#### Funding

This research was funded by the Chinese Center for Disease Control and Prevention for the Special Investigation Project on Occupational Disease Hazards of key population (grant number:

131031109000190002), Humanities and Social Sciences Research Project Fund of Chongqing Municipal Education Commission in 2022, (grant number: NO.22SKGH052).

### Data availability statement

The data sets used and analyzed in this study are available from the corresponding author upon reasonable request.

### Conflict of interest

The authors declare no conflict of interest.

### Acknowledgments

The authors would like to thank all the participants involved in this project for their contribution and dedication sincerely.

### References

- [1] Lu J, Xu X, Huang Y, Li T, Ma C, Xu G, Yin H, Xu X, Ma Y, Wang L, Huang Z, Yan Y, Wang B, Xiao S, Zhou L, Li L, Zhang Y, Chen H, Zhang T, Yan J, Ding H, Yu Y, Kou C, Shen Z, Jiang L, Wang Z, Sun X, Xu Y, He Y, Guo W, Jiang L, Li S, Pan W, Wu Y, Li G, Jia F, Shi J, Shen Z, Zhang N. Prevalence of depressive disorders and treatment in China: a cross-sectional epidemiological study. *Lancet Psychiatry* 2021;8(11):981–90.
- [2] Ren X, Yu S, Dong W, Yin P, Xu X, Zhou M. Burden of depression in China, 1990–2017: findings from the global burden of disease study 2017. *J Affect Disord* 2020;268:95–101.
- [3] Fullerton CS, Ursano RJ, Wang L. Acute stress disorder, posttraumatic stress disorder, and depression in disaster or rescue workers. *Am J Psychiatry* 2004;161(8):1370–6.
- [4] Lourel M, Abdellaoui S, Chevalerey S, Paltrier M, Gana K. Relationships between psychological job demands, job control and burnout among firefighters. *N Am J Psychol* 2008;10(3):489–96.
- [5] Roşca AC, Mateizer A, Dan CI, Demerouti E. Job demands and exhaustion in firefighters: the moderating role of work meaning. A cross-sectional study. *Int J Environ Res Public Health* 2021;18(18).
- [6] Van Eerd D, Irvin E, Harbin S, Mahood Q, Tiong M. Occupational exposure and post-traumatic stress disorder: a rapid review. *Work* 2021;68(3):721–31.
- [7] Wagner SL, White N, Randall C, Regehr C, White M, Alden LE, Buys N, Carey MG, Corneil W, Fyfe T, Matthews LR, Fraess-Phillips A, Krutop E. Mental disorders in firefighters following large-scale disaster. *Disaster Med Public Health Prep* 2021;15(4):504–17.
- [8] Chen X, Zhang L, Peng Z, Chen S. Factors influencing the mental health of firefighters in shantou city, China. *Psychol Res Behav Manag* 2020;13:529–36.
- [9] Tak S, Driscoll R, Bernard B, West C. Depressive symptoms among firefighters and related factors after the response to Hurricane Katrina. *J Urban Health* 2007;84(2):153–61.
- [10] Kunz KR, Turcotte K, Pauer S, Zheng A, Purewal A, Wellar A, Karmali S, Garis L, Thomas LS, Pike I. Cancer in female firefighters: the clinicobiological, psychological, and social perspectives. *Front Public Health* 2023;11:1126066.
- [11] Trivisonno AJ, Laffan MR, Giuliani HK, Mota JA, Gerstner GR, Smith-Ryan AE, Ryan ED. The influence of age on the recovery from worksite resistance exercise in career firefighters. *Exp Gerontol* 2021;152:111467.
- [12] Rush AJ, Trivedi MH, Wisniewski SR, Stewart JW, Nierenberg AA, Thase ME, Ritz L, Biggs MM, Warden D, Luther JF, Shores-Wilson K, Niederehe G, Fava M. Bupropion-SR, sertraline, or venlafaxine-XR after failure of SSRIs for depression. *N Engl J Med* 2006;354(12):1231–42.
- [13] Zhou Y, MacGeorge EL, Myrick JG. Mental health and its predictors during the early months of the COVID-19 pandemic experience in the United States. *Int J Environ Res Public Health* 2020;17(17).
- [14] Escobar D, Noll P, Jesus TF, Noll M. Assessing the mental health of Brazilian students involved in risky behaviors. *Int J Environ Res Public Health* 2020;17(10).
- [15] Hallgren M, Lundin A, Tee FY, Burström B, Forsell Y. Somebody to lean on: social relationships predict post-treatment depression severity in adults. *Psychiatry Res* 2017;249:261–7.
- [16] Yalçın İ. [Relationships between well-being and social support: a meta-analysis of studies conducted in Turkey]. *Turk Psikiyatri Derg* 2015;26(1):21–32.
- [17] Meshi D, Ellithorpe ME. Problematic social media use and social support received in real-life versus on social media: associations with depression, anxiety and social isolation. *Addict Behav* 2021;119:106949.
- [18] Fu C, Wang C, Shi X, Cao F. Social support and depressive symptoms among physicians in tertiary hospitals in China: a cross-sectional study. *BMC Psychiatry* 2021;21(1):217.
- [19] Cacioppo JT, Hawley LC, Thisted RA. Perceived social isolation makes me sad: 5-year cross-lagged analyses of loneliness and depressive symptomatology in the Chicago Health, Aging, and Social Relations Study. *Psychol Aging* 2010;25(2):453–63.
- [20] Pössel P, Burton SM, Cauley B, Sawyer MG, Spence SH, Sheffield J. Associations between social support from family, friends, and teachers and depressive symptoms in adolescents. *J Youth Adolesc* 2018;47(2):398–412.
- [21] VandenBos GR. APA dictionary of psychology. American Psychological Association; 2007.
- [22] Cheng Y, Li X, Lou C, Sonenstein FL, Kalamar A, Jejeebhoy S, Delany-Moretwe S, Brahmabhatt H, Olumide AO, Ojengbede O. The association between social support and mental health among vulnerable adolescents in five cities: findings from the study of the well-being of adolescents in vulnerable environments. *J Adolesc Health* 2014;55(6 Suppl):S31–8.
- [23] Uchino BN. Understanding the links between social support and physical health: a life-span perspective with emphasis on the separability of perceived and received support. *Perspect Psychol Sci* 2009;4(3):236–55.
- [24] Nowicki GJ, Slusarska B, Tucholska K, Naylor K, Chrzan-Rodak A, Niedorys B. The severity of traumatic stress associated with COVID-19 pandemic, perception of support, sense of security, and sense of meaning in life among nurses: research protocol and preliminary results from Poland. *Int J Environ Res Public Health* 2020;17(18).
- [25] Chu PS, Saucier DA, Hafner E. Meta-analysis of the relationships between social support and well-being in children and adolescents. *J Soc Clin Psychol* 2010;29(6):624–45.
- [26] Duko B, Gebeyehu A, Ayano G. Prevalence and correlates of depression and anxiety among patients with tuberculosis at WolaitaSodo university hospital and sodo health center, WolaitaSodo, south Ethiopia, cross sectional study. *BMC Psychiatry* 2015;15:214.
- [27] Grey I, Arora T, Thomas J, Saneh A, Tohme P, Abi-Habib R. The role of perceived social support on depression and sleep during the COVID-19 pandemic. *Psychiatry Res* 2020;293:113452.
- [28] Chatters LM, Taylor RJ, Woodward AT, Nicklett EJ. Social support from church and family members and depressive symptoms among older African Americans. *Am J Geriatr Psychiatry* 2015;23(6):559–67.
- [29] Sheffler J, Sachs-Ericsson N. Racial differences in the effect of stress on health and the moderating role of perceived social support. *J Aging Health* 2016;28(8):1362–81.
- [30] Archibald PC, Dobson Sydnor K, Daniels K, Bronner Y. Explaining African-Americans' depressive symptoms: a stress-distress and coping perspective. *J Health Psychol* 2013;18(3):321–31.
- [31] Feng L, Yin R. Social support and hope mediate the relationship between gratitude and depression among front-line medical staff during the pandemic of COVID-19. *Front Psychol* 2021;12:623873.
- [32] Yu H, Li M, Li Z, Xiang W, Yuan Y, Liu Y, Li Z, Xiong Z. Coping style, social support and psychological distress in the general Chinese population in the early stages of the COVID-19 epidemic. *BMC Psychiatry* 2020;20(1):426.
- [33] Yan L, Gan Y, Ding X, Wu J, Duan H. The relationship between perceived stress and emotional distress during the COVID-19 outbreak: effects of boredom proneness and coping style. *J Anxiety Disord* 2021;77:102328.
- [34] Huang Y, Su X, Si M, Xiao W, Wang H, Wang W, Gu X, Ma L, Li J, Zhang S, Ren Z, Qiao Y. The impacts of coping style and perceived social support on the mental health of undergraduate students during the early phases of the COVID-19 pandemic in China: a multicenter survey. *BMC Psychiatry* 2021;21(1):530.
- [35] Tong X, Chen J, Park SP, Wang X, Wang C, Su M, Zhou D. Social support for people with epilepsy in China. *Epilepsy Behav* 2016;64(Pt A):224–32.
- [36] Asghar MZ, Arif S, Barbera E, Seitamaa-Hakkarainen P, Kocayoruk E. Support through social media and online class participation to enhance psychological resilience. *Int J Environ Res Public Health* 2021;18(22).
- [37] Rappaport LM, Amstadter AB, Neale MC. Model fit estimation for multilevel structural equation models. *Struct Equ Model* 2020;27(2):318–29.
- [38] Wang W, Bian Q, Zhao Y, Li X, Wang W, Du J, Zhang G, Zhou Q, Zhao M. Reliability and validity of the Chinese version of the Patient Health Questionnaire (PHQ-9) in the general population. *Gen Hosp Psychiatry* 2014;36(5):539–44.
- [39] Wang J, Zhang QY, Chen HQ, Sun DY, Wang C, Liu XM, Sun YY, Li S, Yu SF. [Development of the core occupational stress scale for occupational populations in China]. *Zhonghua Yu Fang Yi Xue Za Zhi* 2020;54(11):1184–9.
- [40] Zhou J, Yang Y, Qiu X, Yang X, Pan H, Ban B, Qiao Z, Wang L, Wang W. Relationship between anxiety and burnout among Chinese physicians: a moderated mediation model. *PLoS One* 2016;11(8):e0157013.
- [41] Bentler PM. Comparative fit indexes in structural models. *Psychol Bull* 1990;107(2):238–46.
- [42] Tibbe TD, Montoya AK. Correcting the bias correction for the bootstrap confidence interval in mediation analysis. *Front Psychol* 2022;13:810258.
- [43] Guardino CM, Schetter CD. Coping during pregnancy: a systematic review and recommendations. *Health Psychol Rev* 2014;8(1):70–94.
- [44] de Tyche C, Spitz E, Briançon S, Lighezzolo J, Girvan F, Rosati A, Thockler A, Vincent S. Pre- and postnatal depression and coping: a comparative approach. *J Affect Disord* 2005;85(3):323–6.
- [45] Prasertsi N, Holden J, Keefe FJ, Wilkie DJ. Repressive coping style: relationships with depression, pain, and pain coping strategies in lung cancer outpatients. *Lung Cancer* 2011;71(2):235–40.

- [46] Wang DF, Zhou YN, Liu YH, Hao YZ, Zhang JH, Liu TQ, Ma YJ. Social support and depressive symptoms: exploring stigma and self-efficacy in a moderated mediation model. *BMC Psychiatry* 2022;22(1):117.
- [47] Fu C, Cui X, Geng L, Cao F. Association between social support and depressive symptoms among Chinese nurses with formal employment versus contract-based employment. *Front Psychiatry* 2023;14:1037499.
- [48] Obuobi-Donkor G, Oluwasina F, Nkire N, Agyapong VIO. A scoping review on the prevalence and determinants of post-traumatic stress disorder among military personnel and firefighters: implications for public policy and practice. *Int J Environ Res Public Health* 2022;19(3).
- [49] Ren J, Jiang X, Yao J, Li X, Liu X, Pang M, Chiang CL. Depression, social support, and coping styles among pregnant women after the lushan earthquake in Ya'an, China. *PLoS One* 2015;10(8):e0135809.
- [50] Sherbourne CD, Hays RD. Marital status, social support, and health transitions in chronic disease patients. *J Health Soc Behav* 1990;31(4):328–43.
- [51] Eaton RJ, Bradley G. The role of gender and negative affectivity in stressor appraisal and coping selection. *Int J Stress Manag* 2008;15(1):94.
- [52] González-Morales MG, Peiró JM, Rodríguez I, Greenglass ER. Coping and distress in organizations: the role of gender in work stress. *Int J Stress Manag* 2006;13(2):228.
- [53] Matud MP, Bethencourt JM, Ibáñez I. Gender differences in psychological distress in Spain. *Int J Soc Psychiatry* 2015;61(6):560–8.
- [54] Kelly MM, Tyrka AR, Price LH, Carpenter LL. Sex differences in the use of coping strategies: predictors of anxiety and depressive symptoms. *Depress Anxiety* 2008;25(10):839–46.
- [55] Leach LS, Christensen H, Mackinnon AJ, Windsor TD, Butterworth P. Gender differences in depression and anxiety across the adult lifespan: the role of psychosocial mediators. *Soc Psychiatry Psychiatr Epidemiol* 2008;43(12):983–98.
- [56] Tomioka K, Morita N, Saeki K, Okamoto N, Kurumatani N. Working hours, occupational stress and depression among physicians. *Occup Med (Lond)* 2011;61(3):163–70.
- [57] Wang J, Zou R, Wu N, Fu H, He Y, Crawford P, Kane E, Dai J. Depressive symptoms, social support, and health-related quality of life: a community-based study in Shanghai, China. *Compr Psychiatry* 2022;113:152292.
- [58] Jahnke SA, Poston WS, Haddock CK, Jitnarin N. Obesity and incident injury among career firefighters in the central United States. *Obesity (Silver Spring)* 2013;21(8):1505–8.
- [59] Tao Y, Liu X, Hou W, Niu H, Wang S, Ma Z, Bi D, Zhang L. The mediating role of emotion regulation strategies in the relationship between big five personality traits and anxiety and depression among Chinese firefighters. *Front Public Health* 2022;10:901686.
- [60] He Y, Huang L, Chen J, Long L, Zhang L, Hui X, Zhang Q, Guan M, Xie Y, Sun J. Mental health status and related influencing factors in patients with COVID-19. *BMC Psychol* 2023;11(1):225.