



Print ISSN: 1738-3110 / Online ISSN 2093-7717  
 JDS website: <http://www.jds.or.kr>  
<http://dx.doi.org/10.15722/jds.21.12.202312.47>

# How Did I Get My Order? Unveiling The Distribution Process of E-Retail in Indonesia

Indah FATMAWATI<sup>1</sup>, Salsabila Shafa FAJRIANA<sup>2</sup>

Received: July 22, 2023. Revised: September 29, 2023. Accepted: December 05, 2023.

## Abstract

**Purpose:** Post-purchase service in online platforms has created an exciting focus for consumer behavior studies. This study intends to ascertain the impact of post-purchase shipping dimensions (shipping service, tracking service, return service, and customer care) on customer satisfaction and behavior intention. The authors developed a new model considering behavioral intention as the endogenous variable integrated framework of previous studies. **Research Design and Methodology:** The total sample is 223 respondents, selected using purposive sampling. The data collection uses Google Forms and is analyzed using AMOS Structural Equation Modeling (SEM). **Results:** Our findings showed shipping, tracking, returns, and customer service positively impact customer satisfaction, and customer satisfaction mediates shipping, returns, and customer service on customer behavior intent. Furthermore, customer satisfaction does not affect the effect of tracking service on customer behavior intention. **Conclusion:** Our hypothesis of the relationship between the post-purchase dimension and customer satisfaction was supported. However, only two of our three mediating hypotheses are supported. The mediating effect of customer satisfaction on the post-purchase dimension on behavioral intention is insignificant, while their direct relationship was significant. It showed that, concerning tracking service, customer satisfaction is not a requirement for the customer to perform behavioral intention in an e-retail context.

**Keywords:** Shipping Service, Tracking Service, Return Service, Customer Service, Customer Satisfaction, Customer Behavior Intention.

**JEL Classification Code:** D13, I31, J22, K31

## 1. Introduction

The COVID-19 pandemic has led to a significant surge in e-commerce usage in Indonesia, both during and after the crisis. People must follow health protocol procedures to avoid coronavirus transmission (Sheth, 2020). Implementing lockdowns and social distancing measures restricted physical retail activities, prompting consumers to turn to online shopping platforms as a safe and convenient

alternative (Rahman, 2020; Lazuardi, 2021). In Indonesia, this shift in consumer behavior was facilitated by the increased accessibility and affordability of smartphones and improved telecommunication infrastructure, which increased internet connectivity in the country. Consequently, social media users increased significantly (Satria, 2021; Yunisrina, 2021). This rise in e-commerce usage can be attributed to changing consumer preferences, government support, and the accelerated adoption of digital technologies (Suharyono, 2020; Wijaya, 2021). Suspension of dine-in,

<sup>1</sup> First & Corresponding Author. Doctor of Management, Postgraduate Program, Universitas Muhammadiyah Yogyakarta, 55183, Indonesia. Email: [indahfatmawati@umy.ac.id](mailto:indahfatmawati@umy.ac.id)

<sup>2</sup> Second Author. Junior Researcher, Department of Management, Faculty of Economics and Business, Universitas Muhammadiyah Yogyakarta, 55183, Indonesia. Email: [salsabilashafaf@gmail.com](mailto:salsabilashafaf@gmail.com)

© Copyright: The Author(s)

This is an Open Access article distributed under the terms of the Creative Commons Attribution Non-Commercial License (<http://creativecommons.org/licenses/by-nc/4.0/>) permits unrestricted noncommercial use, distribution, and reproduction in any medium, provided the original work is properly cited.

drive-through, takeout, and home delivery services has become a meaningful option that allows retail enterprises to continue operating in many countries when restrictions on social connections have been imposed (Uzir et al., 2021). These activities impact consumer behavior, especially when shopping for consumer needs.

Because of the new normal lifestyle, traditional business patterns and activities have changed to become digital-minded. Amid the coronavirus pandemic, almost all businesspeople rely heavily on the Internet (German et al., 2022). The rapid growth of the Internet has caused a reflective impact on marketing (Tandon et al., 2017). The COVID-19 pandemic has expanded the diffusion of online shopping, including e-commerce platforms (Kim, 2020). In addition, the advancement of information technology can facilitate fast and flexible online services according to real-time customer requests, making shuttle services cheaper, faster, and more convenient for customers (Lin et al., 2018). This momentum gives opportunities for e-commerce to reach new customers even more.

Research investigating the post-purchase area, especially the distribution aspects after a consumer makes an online order in an e-retail platform, is still limited. This study provides a new and more comprehensive model on this topic by predicting the behavioral intention of the consumer, not only future purchase intention dimensions but also behavioral intention in e-commerce, which has been relatively limited. While numerous studies have examined factors influencing the pre-purchase and purchase stages, fewer studies have delved into the post-purchase phase and its impact on behavioral intention. Notably, a study by Wang (2018) investigated the relationship between post-purchase customer satisfaction and repurchase intention in e-commerce. Chen (2020) examined the link between post-purchase perceived value and behavioral intention in e-commerce and explored the relationship between post-purchase dimensions, such as customer satisfaction and perceived value, and behavioral intention in e-commerce. However, further research is needed to fully understand the complex dynamics and mechanisms underlying post-purchase experiences and their effects on consumers' satisfaction and future intentions in e-commerce.

Research investigating the post-purchase dimensions of customer satisfaction and behavioral intention in Indonesia's e-retail context remains limited. While studies have explored these dimensions in various e-commerce settings, there is a shortage of research focusing on the Indonesian market, which presents an opportunity for current research to fill this gap and provide valuable insights into the post-purchase experiences of Indonesian e-retail consumers, the factors influencing their satisfaction, and how these experiences shape their behavioral intentions. By exploring this topic, researchers can contribute to

understanding consumer behavior in the e-retail landscape, provide actionable recommendations for e-retailers to enhance customer satisfaction, and ultimately drive positive behavioral outcomes in the Indonesian e-commerce market.

## 2. Literature Review

Our study refers to the Theory of Reasoned Action (TRA) and Service Quality/SERVQUAL (Service Quality). TRA is a social psychology focusing on behavior and its determinants: attitudes toward behavior and subjective norms. The theory explains the factors influencing human behavior and describes the relationship between beliefs, attitudes, subjective norms, intentions, and individual behavior. TRA has been widely applied to assess people's choice to adopt technology, innovation, and consumer behavior. This theory focuses on an individual's intention to behave a certain way. TRA has been developed since 1960 by Fishbein and then set again by (Fishbein & Ajzen, 1975).

On the other hand, Service Quality (SERVQUAL) is the perceived result of a "comparison of consumer expectations with actual service performance" (Parasuraman et al., 1985). SERVQUAL is the outcome of the service delivery system perceived by its users (Martínez & Martínez, 2010). Service quality involved media where customers could communicate with sellers through e-commerce platforms. The products will be transferred from sellers to customers through logistics distribution. Customers will experience and perceive the performance of the e-commerce platform and logistics distribution services. Customers' perceived service quality, in turn, will affect their satisfaction (Vakulenko et al., 2019). SERVQUAL models customer expectations as perceived benefits or values customers seek when receiving services or purchasing goods. Customer perception is a concept that includes the customer's positive or negative feelings (Hiu et al., 2020). Our research framework considers several constructs under those two theories above, consisting of two dimensions of e-commerce and logistics service quality.

### 2.1. Customer Service

Customer service is the form of actions or performances delivered from one party to another whose essence is intangible and does not produce ownership (Kotler & Keller, 2016). Customer service encompasses all retail operations that improve the value customers evaluate when purchasing (Levy & Weitz, 2007). Good service can be a compelling competitive advantage for business people because it is one way to distinguish one's products from others available in the market (Murali et al., 2016).

### 2.2. Shipping Service

Shipping service is transporting goods purchased by customers from the source location to a predetermined destination (Yu et al., 2014). Shipping service is when the sender considers speed, frequency, dependence, capability, availability, traceability, and cost (Kotler & Keller, 2016). Shipping service is a function that includes the movement and storage of materials on their way from the initial sender through the supply chain to the final customer (Walters, 2003).

### 2.3. Tracking Service

Tracking service is a feature that can be utilized by consumers who can provide up-to-date information on goods or documents sent or received with a receipt number as the identity of the services offered. The tracking service monitors the ability to track a consumer order package as it moves from the sender's place to the address where the consumer is the buyer of the goods. When a seller sends consumer-owned ordered goods, the retailer expects the logistics service provider to handle the tracking details of consumer goods sent via the Internet so that customers can keep track of the progress and whereabouts of their order packages (Riley & Klein, 2019). It can help to reduce the crushing defeat to the customer's ordered goods or other workplace accidents.

### 2.4. Return Service

Return service is the return of the further dimension of return management (Bernon et al., 2016). It is the return process involved in identifying different stages. However, most of its activities are related to returns or reverse logistics. A return policy is a tool retailers use to reduce consumer risk and increase demand, as they will be allowed to send back purchased goods for various reasons (Janakiraman et al., 2016). Returns are part of the post-purchase element of logistics (Lysenko-Ryba, 2017).

### 2.5. Customer Satisfaction

Customer satisfaction is the happiness or disappointment of comparing the perceived product performance (or results) and the expectations received from a product or service (Kotler & Keller, 2016). Lovelock and Wirtz (2010) defined customer satisfaction as an emotional state; post-purchase reactions can be anger, irritation, dissatisfaction, excitement, and neutrality when consumer needs, desires, and expectations are met towards the ordered product.

### 2.6. Customer Behavioral Intention

Consumer behavior studies how individuals, groups, and organizations select, buy, use, and disposition goods, services, ideas, or experiences to satisfy their needs and desires (Kotler & Keller, 2016). The intention to use ICT (Information and Communication Technology) is used widely in information system studies as a dependent variable that reflects the user's choice or as a substitute for actual use (Y. Wang et al., 2020). Fishbein and Ajzen (1975) proposed the relationship between cognition, intention, and behavior as their premise in the Theory of Reasoned Action, which states that "intention is collectively determined by one's attitudes and subjective norms regarding behavior and intention predicting behavior.

### 2.7. The Effect of Customer Service on Customer Satisfaction

The perceived quality of professionalism will reflect product performance and general consumer appreciation for customer service representatives who have demonstrated expertise and consistently delivered on time (Hsin Chang & Wang, 2011). Quality impels customers to establish a strong relationship with the company. In the long term, this kind of bond allows companies to carefully understand customer expectations and their needs to increase customer satisfaction by maximizing pleasant customer experiences and minimizing or eliminating unpleasant customer experiences. As a result, customer service becomes an indicator of customer satisfaction. Customer service is the main factor affecting e-commerce buyer satisfaction (Rajendran et al., 2018). The quality of service to customers has a close relationship with customer satisfaction. The creation of quality service to customers can provide customer satisfaction; this is because the quality of service to customers is one of the factors in realizing customer satisfaction and expectations. Customer service positively impacts customer satisfaction (Abd Ghani et al., 2017; Kursunluoglu, 2011; Rahi & Ghani, 2016; Rita et al., 2019). Hence, we developed the following hypothesis.

**H1:** Customer service positively affects customer satisfaction

### 2.8. The Effect of Shipping Service on Customer Satisfaction

The delivery service that the customer assesses is timeliness because this can affect customer satisfaction, which will impact the assessment of the good or bad of a service delivery company. Estimated arrival time is usually a benchmark for customers to determine whether the service is good. Liu and Kao (2021) state that logistics distribution is the main factor that positively affects customer

satisfaction in e-commerce. Gregory and Van H. (1964) state that shipping service is the quality of the availability of information when needed or the quality of good news in terms of time. It is the degree to which an activity is completed at the desired time by considering the coordination of other outputs and the time available for other activities (Bernandin & Russel, 2000). This opinion is supported by Yuen and Thai (2015), who stated that the service quality of shipping, responsiveness, speed, value, and reliability cause customer satisfaction. The higher the level of service quality in satisfying customers, the higher the level of customer satisfaction (Kotler & Keller, 2016). Cao et al. (2018) and Liu and Kao (2021) found that shipping service positively impacts customer satisfaction. Thus, we developed the following hypothesis.

**H2:** Shipping service has a positive effect on customer satisfaction

## **2.9. The Effect of Tracking Service on Customer Satisfaction**

Accurate information about the existence of a product is critical for customers to ensure the product they want does not exceed the specified time (Laudon & Traver, 2014). Electronic-based service quality is an effort to fulfill needs followed by consumer desires and the accuracy of the delivery method through electronic media to meet customer expectations and satisfaction (Band, 1991). Chase and Aquilano (2006) argue that customers determine the quality of a company through the characteristics of a product and service; customer satisfaction is influenced by the value obtained by consuming a service. The tracking system is a feature for customers to provide the latest information regarding documents or goods received or sent. It significantly influences customer satisfaction. The tracking system service can positively affect customer satisfaction (Huang et al., 2009; Schaupp, 2005; Shah et al., 2014). Therefore, we developed a hypothesis regarding this idea.

**H3:** Tracking service positively affects customer satisfaction.

## **2.10. The Effect of Return Service on Customer Satisfaction**

Return service is how retailers deal with defective, unwanted, incorrect products because they must be returned and how the right product can be replaced. Transactions carried out online have relatively low trust for online shop customers; often, customers who think that the online shop can easily deceive customers at first. With a return service, customer trust can increase because a refund or return of goods can mean the seller doesn't take the customer's money for granted. Customers are also increasingly confident in

making transactions online. Return service to consumers is a way or policy to overcome uncertainty because consumers cannot get the opportunity to try or feel the product physically (Saarijärvi et al., 2017). Consumers can consider this service return as a barrier from risks that can increase consumer demand and as a driver for customer satisfaction. Lysenko-Ryba (2017) explained that one of the dissatisfaction factors is the lack of return services for goods in a company. It means that having a positive experience during the return process from the seller will lead to the customer's satisfaction, who is likely to make another purchase, and the customer can recommend it to others. Jalil (2019) and Khan et al. (2015) argued that return service has significant to customer satisfaction. Based on the above, we develop our hypothesis below:

**H4:** Return service has a positive effect on customer satisfaction.

## **2.11. The Effect of Customer Satisfaction on Customer Behavioral Intention**

High customer satisfaction will undoubtedly directly or indirectly impact positive behavior intentions (Liang & Zhang, 2011). Bloemer, Schoder, and Kestens (2007) found that consumer satisfaction influences repurchasing intentions. High consumer satisfaction will encourage the intent to purchase the product. Perceived service quality and a credible company image will affect customer satisfaction and behavior intention (Srivastava and Sharma 2013), such as WOM (Word of Mouth), repurchase, and recommendations. Elbeltagi and Agag (2016), Gounaris et al. (2010), and Srivastava and Sharma (2013) concluded that customer satisfaction could affect consumers' behavior with repurchase intentions. The following is our hypothesis regarding this relationship.

**H5:** Customer satisfaction positively affects customer behavior intention.

## **2.12. The Effect of Customer Service on Customer Behavioral Intention Through Satisfaction**

Customer service directly affects behavioral intention and indirectly through satisfaction (Xiao et al., 2020). Customers will feel satisfied and loyal when they get good service. The service quality will affect customer satisfaction directly. When the customer's assessment of the service's quality is high, the customer will consider reusing the service. Customers' satisfaction will influence behavioral intentions. When users repeatedly use these services, a habit is developed. The study of Xiao et al. (2020) and Yu et al. (2014) explained that service quality positively affects behavior intention through customer satisfaction. Based on this idea, we proposed the following hypothesis.

**H6:** Customer service positively relates to customer behavior intention through customer satisfaction.

### 2.13. The Effect Shipping on Customer Behavioral Intention Through Customer Satisfaction

E-commerce must provide customers with a good delivery service experience to trigger them to commit to repurchasing behavior intentions to which they will eventually be loyal. Customer satisfaction can be considered a valuable "asset" for the company. Therefore, timely delivery of products can increase customer satisfaction and affect behavioral intention. E-service affects customer satisfaction and behavior intentions (Gounaris et al., 2010; Khairani & Hati, 2017; Liang & Zhang, 2011; Lien et al., 2011). Therefore, the service positively affects the intention of repurchase behavior.

**H7:** Shipping service significantly affects customer behavior intention through customer satisfaction.

### 2.14. The Effect of Tracking Service on Customer Behavioral Intention Through Customer Satisfaction

E-service drivers or tracking services can build customer loyalty and WOM (Word of Mouth) and motivate customers to repurchase. The tracking service will help customers to track their goods. If the tracking service is running well and the use of tracking is also easy to use, then the customer is satisfied and feels that their package is safe. This system can minimize the loss of the customer's ordered goods or other workplace accidents. The goods sent can arrive at the consumer's destination address according to the schedule and delivery plan. So, customer service affects customer satisfaction and behavioral intentions (Gounaris et al., 2010; Liang & Zhang, 2011). Customers will feel satisfied and loyal when they get good customer service. Then, we developed the following hypothesis:

**H8:** Tracking service positively affects customer behavior intention through customer satisfaction.

### 2.15. The Effect of Return Service on Customer Behavioral Intention Through Customer Satisfaction

Customers will be satisfied if there is a return service if the goods sent are unsuitable or for other reasons. This service will make the customer not feel aggrieved because the e-commerce party is trying to replace it. It will make the customer feel satisfied and likely trigger the customer to make repeat purchase behavior intentions. Buyers will be satisfied if the services provided by e-commerce make it easier for them and reduce the risk of bad judgment; this

incident will be a determinant of customer satisfaction, which then impacts behavioral intentions. Customer service affects customer satisfaction and behavioral intentions (Gounaris et al., 2010; Liang & Zhang, 2011). Thus, we proposed the following hypothesis.

**H9:** Return service positively affects customer behavior intention through customer satisfaction.

Our research model is shown in Figure 1 below. Based on Figure 1, we identified the antecedents and consequences of customer satisfaction toward post-purchase shipping. In the context of post-purchase shipping satisfaction, we identified customer service, shipping service, tracking service, and return service as the antecedents. The proposed consequence of customer satisfaction is customer behavioral intention.

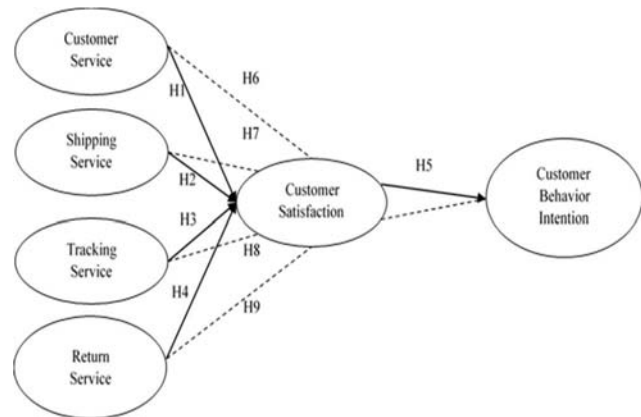

Figure 1: Research Model

## 3. Method, Data, and Analysis

This study employs a quantitative method using an explanatory survey design. The respondents are consumers living in the Special Region of Yogyakarta, Indonesia, and have shopped at a popular e-commerce site in Indonesia (Shopee) at least twice. The primary data collection uses Google form links. Two hundred and eighteen respondents filled out the questionnaires, and all received responses were usable for further data analysis.

The exogenous variables in this study are customer service, shipping service, tracking service, and return service. Customer service was adapted from Cao et al. (2018) with five indicators: fast service, good service, always being able to resolve customer complaints, always being willing to help, and exemplary service as needed. Shipping service indicators also adapted from Cao et al. (2018) include delivery as agreed, receiving the package on time, delivery options as desired, receiving free/discounted delivery, and

receiving the package in a safe condition. Tracking service measurement uses five indicators, which also adapted from Cao et al. (2018) and Weisberg, Te'eni, and Arman (2011), including tracking number information via email, tracking shipments via the website, updated and real-time package information, accurate package arrival information, very efficient. Return services indicators were adapted from Cao et al. (2018) five indicators: easy-to-re return/exchange, clear return policy, hassle-free return process, no return fees for non-conformances, and fast return service. The intervening variable in this study is customer satisfaction. We measured this variable in five questions referring to Cao et al. (2018): satisfied with the customer service, satisfied with the shipping service, delighted with the tracking service, pleased with the return service, and satisfied with the overall service. The endogenous variable in this study is customer behavior intentions. This variable is measured in five questions adapted from Gounaris et al. (2010): recommend close relatives, share experiences with close relatives, say positive things, do shopping again, and will not switch to other e-commerce. The variable measurement uses a five-point Likert scale, from strongly disagree to strongly agree.

## 4. Results and Discussion

### 4.1. Result

The characteristics of respondents based on gender, age, area of residence in the Special Region of Yogyakarta, Indonesia, education, employment, and monthly expenses are shown in Table 1.

**Table 1:** Respondent Profiles

Characteristic Respondents	Information	Frequency	Percentage
Gender	Female	143	66%
	Male	75	34%
	Total	218	100%
Age	19 - 22	204	93,5%
	23 - 26	14	6,5%
	Total	218	100%
Residence	Sleman	109	50,0%

**Table 2:** Validity and Reliability Test

Variables	Indicators	Factor Loading	Construct Reliability
Customer Service (X <sub>1</sub> )	Received prompt service from this marketplace	0.871	0.892
	Feel this marketplace shows good service in solving customer problems	0.901	
	Feel this marketplace customer service can always resolve customer complaints	0.841	
	Feel this marketplace is always willing to help customers	0.892	
	Feel this marketplace provides exemplary service according to customer needs	0.875	

Characteristic Respondents	Information	Frequency	Percentage
	Bantul	87	39,9%
	Yogyakarta City	13	6,0%
	Kulon Progo	5	2,3%
	Gunung Kidul	4	1,8%
	Total	218	100%
Education	Junior	0	0%
	Senior High School	167	76,6%
	Diploma	43	19,7%
	Bachelor	8	3,7%
	Total	218	100%
Occupation	Student	2	0,9%
	Student	175	80,3%
	Civil servants	0	0,0%
	Private Sector	26	11,9%
	Military/Police	2	0,9%
	Entrepreneur	6	2,7%
	Housewives	2	0,9%
	Other	5	2,3%
	Total	218	100%
Monthly Expenses (in IDR)	≤Rp 2,500,000	184	84,4%
	>Rp.2.500.000 – ≤ Rp.5.000.000	29	13,3%
	>Rp.5.000.000 – ≤ Rp.7.500.000	5	2,3%
	>Rp.7.500.000 – ≤ Rp.10.000.000	0	0%
	>Rp.10.000.000 – ≤ Rp.15.000.000	0	0%
	>Rp.15.000.000	0	0%
	Total	218	100%

We conducted the instrument validity and reliability as shown in Table 2. Based on Table 2, all the loading factor values were greater than 0.5, meaning all the items were valid. Hair et al. (2010) stated that data is valid if the factor loading value exceeds 0.5. The reliability test results also show that all the constructs were reliable since they were greater than 0.7. We use Construct Reliability criteria greater than 0.7 (Hair et al., 2010). Thus, we concluded that the research instruments were valid and reliable.

Variables	Indicators	Factor Loading	Construct Reliability
Shipping Service (X <sub>2</sub> )	Received product delivery based on the agreed time / estimated	0.884	0.883
	Often receive packages within the expected timeframe/on time	0.891	
	Often find delivery options according to those that are in demand	0.831	
	Often receive free/discounted shipping	0.803	
	Received the package safely	0.904	
Tracking Service (X <sub>3</sub> )	Got an email or text notification with the tracking number (receipt)	0.588	0.785
	Can track the shipment directly on the website	0.753	
	Got the updated information and real-time packages quickly from the website	0.671	
	Got information from the website regarding the arrival time of the package accurately	0.693	
	Feel this marketplace tracking service is very efficient	0.689	
Return Service (X <sub>4</sub> )	Find it easy to make a return/exchange	0.639	0.793
	Feel this marketplace has a clear return policy	0.709	
	Have no problems in the process of returning returned goods	0.725	
	Do not pay the shipping fee on the returned item for non-conformity to the goods received	0.720	
	Got a quick return process service	0.731	
Customer Satisfaction (Z)	Satisfied with this marketplace customer service	0.678	0.795
	Satisfied with this marketplace delivery service	0.665	
	Satisfied with this marketplace tracking service	0.700	
	Satisfied with this marketplace return service	0.760	
	Satisfied with this overall marketplace service	0.737	
Customer Behavior Intention (Y)	Would recommend close relatives do online shopping on this marketplace	0.865	0.825
	Will share my online shopping experience at this marketplace with close relatives	0.714	
	Will tell the positives to others	0.798	
	Intend to do online shopping in this marketplace again	0.713	
	Will not switch to other e-commerce besides this marketplace	0.751	

Our next step is testing the proposed model to ensure that it meets the Fit criteria of the model by identifying the Goodness of Fit based on several criteria, as shown in Figure 2. Based on Figure 2, we got the model test results found on the Goodness of Fit criteria of the SEM AMOS

model. Our framework involved six exogenous variables: customer service, shipping service, tracking service, and return service. Customer behavior intention is the endogenous variable, and the intervening variable is customer satisfaction.

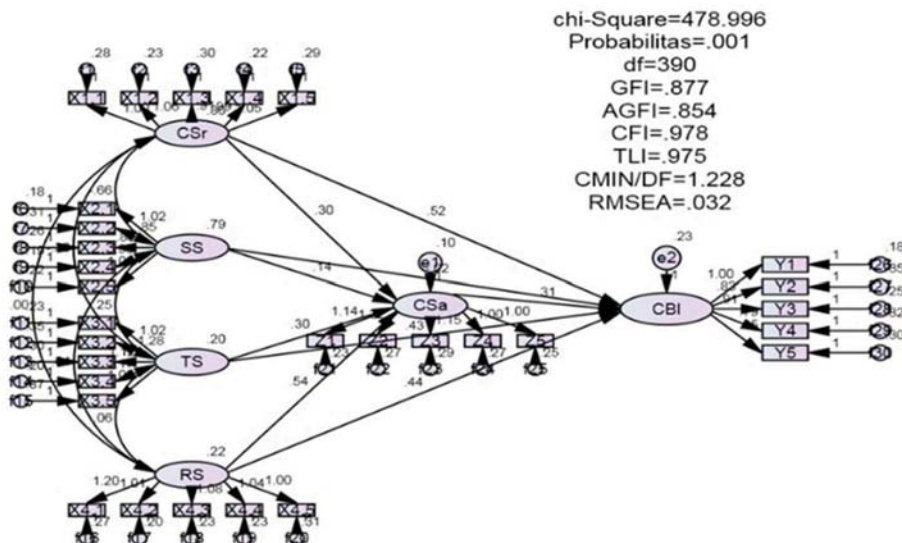

Figure 2: Model Test Results

Based on the estimated model test results, we showed the Goodness of Fit Index in Table 3. to see how much the hypothesized model matches the data sample or "Fit." Table 3 shows five of the eight Goodness of Fit Index criteria

showed Fit results. Therefore, we concluded that our proposed model could be used for further analysis of hypotheses testing.

**Table 3:** Assessing Goodness of Fit

No.	The Goodness of Fit Index	Cut-off value	Result	Model Evaluation
1.	Chi-Square	Expected small	478.996	Fit
2.	Significant Probability	$\geq 0.05$	0.001	Not Fit
3.	GFI	$\geq 0.90$	0.877	Marginal
4.	RMSEA	$\leq 0.08$	0.032	Fit
5.	CMIN/DF	$\leq 2.00$	1.228	Fit
6.	AGFI	$\geq 0.90$	0.854	Marginal
7.	TLI	$\geq 0.90$	0.975	Fit
8.	CFI	$\geq 0.90$	0.978	Fit

The following section discusses the results of hypotheses testing, as shown in Table 4. Hypothesis testing aims to confirm the proposed relationship of variables in the structural model of the study. The hypothesis test results are displayed in the Regression Weight section, which shows

the coefficient of influence between variables. To determine whether the hypothesis is accepted, we use the Critical Ratio (CR) value, which has a value greater than 1.96 and a probability value (p) smaller than alpha 0.05.

**Table 4:** Relationship Between Variables

	Estimate	SE.	CR	P	Hypothesis
Customer Service → Customer Satisfaction	0.303	0.076	3.976	0.000	Significant Positives
Shipping Service → Customer Satisfaction	0.141	0.061	2.316	0.021	Significant Positives
Tracking Service → Customer Satisfaction	0.296	0.135	2.187	0.029	Significant Positives
Return Service → Customer Satisfaction	0.542	0.098	5.536	0.000	Significant Positives
Customer Satisfaction → Customer Behavior Intention	0.314	0.157	1.995	0.046	Significant Positives

Based on Table 4, we summarized the results of the hypotheses testing. Our hypothesis 1 testing showed that the estimated parameter value for the standardized regression weight factor was 0.303, and the CR value of 3.976 exceeds 1.96. Testing the relationship between the two variables showed a probability value 0.000, smaller than 0.05. Thus, hypothesis 1 states, "Customer service positively affects customer satisfaction," which is supported. Secondly, hypothesis 2 showed that the estimated parameter value for the standardized regression weight factor is 0.141. The CR value is 2.316, which is greater than 1.96. Testing the relationship between the two variables showed a probability value of 0.021, which is smaller than 0.05. This result indicates that hypothesis 2, which states that shipping service positively affects customer satisfaction, is supported. Thirdly, our hypothesis 3 test results demonstrated the estimated parameter value for the standardized regression weight factor was 0.296, and the CR value was 2.187, which exceeds 1.96. Testing the relationship between the two variables showed a probability value of 0.029, smaller than 0.05. Thus, our hypothesis 3, which states tracking service positively affects customer satisfaction, is supported. Fourthly, the hypothesis 4 testing result indicated that the

estimated parameter value for the standardized regression weight factor was 0.542, and the CR value was 5.536, greater than 1.96. Testing the relationship between the two variables showed that the probability value 0.000 was smaller than 0.05. Therefore, our hypothesis 4, which states return service positively affects customer satisfaction, is supported. Lastly, our hypothesis 5 testing result showed that the parameter value estimated for the standardized regression weight factor was 0.314. The CR value was 1.995, which was more significant than 1.96. Testing the relationship between the two variables showed a probability value of 0.046, smaller than 0.05. It means our hypothesis 5, which affirms customer satisfaction affects customer behavior intention, is supported.

To test the mediating hypotheses, we compared the values of standardized direct effects to see the mediation relationship between independent and dependent variables through mediation variables. If the direct standardized impact is smaller than the value of the standardized indirect effects, the mediation variable indirectly influences the relationship between the two variables. The results of mediating effects are shown in Table 5 and Table 6.



**Table 5.** Standardized direct effects

	Customer Service (X1)	Shipping Service (X2)	Tracking Service (X3)	Return Service (X4)	Customer Satisfaction (Z)	Customer Behavior Intention (Y)
Customer Satisfaction (Z)	0.615	0.273	0.285	0.550	0.000	0.000
Customer Behavior Intention (Y)	0.122	-0.027	0.260	0.109	0.198	0.000

**Table 6.** Standardized indirect effects

	Customer Service (X1)	Shipping Service (X2)	Tracking Service (X3)	Return Service (X4)	Customer Satisfaction (Z)	Customer Behavior Intention (Y)
Customer Satisfaction (Z)	0.000	0.000	0.000	0.000	0.000	0.000
Customer Behavior Intention (Y)	0.666	0.054	0.056	0.284	0.000	0.000

The following section discusses the mediating effects of test results based on Tables 5 and 6. Initially, for hypothesis 6 testing, we compare whether the value of the direct impact is smaller than the value of the indirect effect. Testing the relationship between the two variables showed a value of 0.122, smaller than 0.666. It shows that the value of the direct result is less than the value of the indirect impact. These results mean that hypothesis 6 is supported, representing customer satisfaction mediates customer service to customer behavior intention. Then, for our hypothesis 7 test, we also compared whether the direct effect values were smaller than the indirect effect values. The result showed that the relationship between the two variables was -0.027, smaller than 0.054. It shows that hypothesis 7 supports customer satisfaction and mediates shipping service to customer behavior intention. For hypothesis 8 with the same technique, we found the relationship between the two variables shows a value of 0.260 greater than 0.056. It indicates that hypothesis 8 is not supported. It means customer satisfaction does not mediate tracking service to customer behavior intention. Finally, hypothesis 9 testing results showed a value of 0.109, smaller than 0.284. It indicates that hypothesis 9 supports customer satisfaction mediates return service to customer behavior intention.

**4.2. Discussion**

We got support for our first five hypotheses based on the hypothesis testing, and these results also supported the previous research findings. Based on the first hypothesis testing result, customer service positively influences customer satisfaction. It proves that a better quality of customer service provides higher customer satisfaction. The results of this study align with Cao et al. (2018) and Rajendran et al. (2018). Our result of the second hypothesis testing showed that shipping service positively influences customer satisfaction. It proves that the better the quality of shipping service, the higher customer satisfaction. This finding aligns with Cao et al. (2018), Liu and Kao (2021),

and Yuen and Thai (2015). Our third hypothesis testing revealed that tracking services positively influence customer satisfaction. It proves that the better the quality of tracking services, the higher customer satisfaction. This study’s results align with Cao et al. (2018) and Gounaris et al. (2010). Our fourth hypothesis testing results show that return service positively influences customer satisfaction. It proves that a better quality of return service means higher customer satisfaction. In addition, the results of this study align with those of Cao et al. (2018). Our fifth hypothesis test finding shows that customer satisfaction positively influences customer intention. It proves that the higher customer satisfaction, the better customer behavioral intentions. The results of this study align with Gounaris et al. (2010) and Liang and Zhang (2011).

**5. Conclusion**

We concluded, except for the eighth, that the bulk of our proposed hypotheses were supported based on the findings of our hypothesis testing. According to the findings, customer, shipping, tracking, and return service positively impact customer satisfaction. Customer satisfaction also positively impacts customer behavioral intention. Results of mediating hypothesis testing showed that customer satisfaction indirectly mediates the relationship between shipping service, return service, and customer service to customer behavior intention. However, customer satisfaction does not mediate the relationship between tracking service and customer behavior intention (although the direct effect of each variable is significant). This finding implies that marketers must concentrate on increasing customer satisfaction. It can be accomplished, in our opinion, by improving the quality of customer service, shipping, tracking, and return services to avoid customer dissatisfaction, as it becomes the source of customer satisfaction. We also demonstrated that good customer behavior intention requires customer satisfaction. Again, this result emphasized maintaining customer satisfaction in

post-purchase service dimensions. Our findings revealed a critical aspect of the quality of e-commerce services in online businesses and generated new knowledge to improve previous understanding of e-commerce service quality.

This study also improves e-commerce users' prior knowledge of post-purchase shipping: shipping service, tracking service, return service, and customer service concerning customer behavior intention and satisfaction as intervening variables. Although we supported the majority of our hypotheses, we recognize that this study has limitations. We restrict the survey to residents of a Special Region of Yogyakarta, Indonesia, and use a single marketplace with a small sample size. As a result, we propose that future studies broaden the sample and research setting beyond a single market. Future research needs to expand the geographic scope of sample selection to improve the sample representativeness and generalizability of the research findings.

## References

- Abd Ghani, M., Mohd Yasin, N., & Alnaser, F. (2017). Adoption of Internet Banking: Extending the Role of Technology Acceptance Model (TAM) with E-Customer Service and Customer Satisfaction Technology Acceptance Model View project The Influence of Services Marketing Mix (7 Ps.) and subjective Norms on Custom. *World Applied Sciences Journal*, 35(9), 1918–1929. <https://doi.org/10.5829/idosi.wasj.2017.1918.1929>
- Band, W. A. (1991). *Creating Value for Costumer: Designing and Implementation a Total Corporate Strategy*. John Walley and Sons Inc, Canada.
- Bernardin, H. J., & Russel, J. E. A. (2000). *Human Resources Management*. Singapore: McGraw-Hill.
- Bernon, M., Cullen, J., & Gorst, J. (2016). Online retail returns management: Integration within an omni-channel distribution context. *International Journal of Physical Distribution and Logistics Management*, 46(6–7), 584–605. <https://doi.org/10.1108/IJPDLM-01-2015-0010>
- Bloemer, J., Schoder, G. O., & Kestens, L. (2007). The Impact of Need for Social Affiliation and Consumer Relationship Proneness on Behavioural Intentions. *Journal of Statistical Software*, 18(2), 3–6.
- Cao, Y., Ajjan, H., & Hong, P. (2018). Post-purchase shipping and customer service experiences in online shopping and their impact on customer satisfaction: An empirical study with comparison. *Asia Pacific Journal of Marketing and Logistics*, 30(2), 400–416. <https://doi.org/10.1108/APJML-04-2017-0071>
- Chase, R. B., & Aquilano, N. J. (2006). *Operations Management for Competitive Advantage*. (9th ed.). McGraw-Hill. New York.
- Chen, Y. (2020). How post-purchase perceived value influences behavioral intentions in the context of e-commerce. *International Journal of Information Management*, 52(102055).
- Elbeltagi, I., & Agag, G. (2016). E-retailing ethics and its impact on customer satisfaction and repurchase intention: A cultural and commitment-trust theory perspective. *Internet Research*, 26(1), 288–310. <https://doi.org/10.1108/IntR-10-2014-0244>
- Fishbein, M., & Ajzen, I. (1975). *Belief, Attitude, Intention, and Behavior: An Introduction to Theory and Research*.
- German, J. D., Redi, A. A. N. P., Prasetyo, Y. T., & Persada., S. F. (2022). Choosing a package carrier during the COVID-19 pandemic: Integrating pro-environmental planned behavior (PEPB) theory and service quality (SERVQUAL). *Journal of Cleaner Production*, 346, 1–17. <https://doi.org/https://doi.org/10.1016/j.jclepro.2022.131123>
- Gounaris, S., Dimitriadis, S., & Stathakopoulos, V. (2010). Examining the effects of service quality and satisfaction on customers' behavioral intentions in e-shopping. *Journal of Services Marketing*, 24(2), 142–156. <https://doi.org/10.1108/08876041011031118>
- Gregory, & Van H. (1964). *Automatic Data-Processing Systems: Principles and Procedures* (1st ed.). Belmont, Calif.: Wadsworth Publishing Company.
- Hair, J. F., Black, W. C., Babin, B. J., & Anderson, R. E. (2010). *Multivariate Data Analysis*. In *Vectors*. <https://doi.org/10.1016/j.ijpharm.2011.02.019>
- Hiu, V., Chan, Y., Chiu, D. K. W., & Ho, K. K. W. (2020). Mediating effects on the relationship between perceived service quality and public library app loyalty during the COVI era. *Jol of Retailing and Consumer Services*, January. <https://doi.org/10.1016/j.jretconser.2022.102960>
- Hsin Chang, H., & Wang, H. (2011). The moderating effect of customer perceived value on online shopping behaviour. *Online Information Review*, 35(3), 333–359. <https://doi.org/10.1108/14684521111151414>
- Huang, Y., Kuo, Y., & Xu, S. (2009). Applying Importance-Performance Analysis to Evaluate Logistics Service Quality for Online Shopping Among Retailing Delivery. *International Journal of Electronic Business Management*, 7(2), 128–136.
- Jalil, E. E. A. (2019). Customer Satisfaction and Reverse Logistics in E-Commerce: the Case of Klang V. *Journal.Oscm-Forum.Org*, 1–9.
- Janakiraman, N., Syrdal, H. A., & Freling, R. (2016). The Effect of Return Policy Leniency on Consumer Purchase and Return Decisions: A Meta-analytic Review. *Journal of Retailing*, 92(2), 226–235. <https://doi.org/10.1016/j.jretai.2015.11.002>
- Khairani, I., & Hati, S. R. H. (2017). The Effects of Perceived Service Quality towards Customer Satisfaction and Behavioral Intentions in Online Transportation. *International Journal of Humanities and Management Sciences (IJHMS)*, 5(1), 7–11.
- Khan, S. A., Liang, Y., & Shahzad, S. (2015). An Empirical Study of Perceived Factors Affecting Customer Satisfaction to RePurchase Intention in Online Stores in China. *Journal of Service Science and Management*, 8(3), 291–305. <https://doi.org/https://doi.org/10.4236/j>
- Kim, R. Y. (2020). The Impact of COVID-19 on Consumers: Preparing for Digital Sales. *IEEE Engineering Management Review*, 48(3), 212–218. <https://doi.org/10.1109/EMR.2020.2990115>
- Kotler, P., Keller, K. L. & Chernev, A. (2016). *Marketing Management*. Sixteenth Edition. Global Edition. Pearson. United Kingdom.
- Kursunluoglu, E. (2011). Customer service effects on customer satisfaction and loyalty: a field research in shopping centers in

- Izmir City - Turkey. *International Journal of Business & Social Science*, 2(17), 52.
- Laudon, Kenneth C., & Traver, C. Guerdo. (2014). *E-Commerce, Business Technology Society*. USA: Addison Wesley.
- Lazuardi, L. (2021). The role of e-commerce during the COVID-19 pandemic: A case study of Indonesia. In *2021 International Conference on Computer Science, Information Technology and Electrical Engineering (CSITEE)*, 1–6.
- Levy, M., & Weitz, B. A. (2007). *Retailing Management*. New York: McGraw Hill.
- Liang, R. Da, & Zhang, J. S. (2011). The effect of service interaction orientation on customer satisfaction and behavioral intention: The moderating effect of dining frequency. *Procedia - Social and Behavioral Sciences*, 24, 1026–1035. <https://doi.org/10.1016/j.sbspro.2011.09.082>
- Lien, C. H., Wen, M. J., & Wu, C. C. (2011). Investigating the relationships among E-service quality, perceived value, satisfaction, and behavioral intentions in Taiwanese online shopping. *Asia Pacific Management Review*, 16(3), 211–223.
- Lin, J., Zhou, W., & Du, L. (2018). Is on-demand same-day package delivery service green? *Transport and Environment*, 61, 118–139. <https://doi.org/10.1016/j.trd.2017.06.016>
- Liu, X., & Kao, Z. (2021). Research on influencing factors of customer satisfaction of e-commerce of characteristic agricultural products. *Procedia Computer Science*, 199, 1505–1512. <https://doi.org/10.1016/j.procs.2022.01.192>
- Lovelock, C. H., & Wirtz, J. (2010). Services Marketing - People, Technology, Strategy. In *Harvard Business Review*.
- Lysenko-Ryba, K. (2017). The Impact of Reverse Logistics on Customer Satisfaction Reverse Logistics Is One of Many Lines of Research in the Area of Supply Chain Manage. *Przedsiębiorczość i Zarządzanie*, 18(January 2017), 137–146.
- Martínez, J. A., & Martínez, L. (2010). Some insights on conceptualizing and measuring service quality. *Journal of Retailing and Consumer Services*, 17(1), 29–42. <https://doi.org/10.1016/j.jretconser.2009.09.002>
- Murali, S., Pugazhendhi, S., & Muralidharan, C. (2016). Modeling and investigating the relationship of after-sales service quality with customer satisfaction, retention, and loyalty - A case study of home appliances businesses. *Journal of Retailing and Consumer Services*, 30, 67–83. <https://doi.org/https://doi.org/10.1016/j.jretconser.2016.01.001>
- Parasuraman, A., Zeithaml, V. A., & Berry, L. L. (1985). A Conceptual Model of Service Quality and Its Implications for Future Research. *Journal of Marketing*, 49(4), 41–50.
- Rahi, S., & Ghani, M. A. (2016). Customer's Perception of Public Relations in E-commerce and its Impact on E-loyalty with Brand Image and Switching Cost. *Journal of Internet Banking and Commerce*, 21(3).
- Rahman, R. (2020). E-commerce trends during the COVID-19 pandemic: A case study of Indonesia. In *2020, the 4th International Conference on Innovative Research and Development (ICIRD)*, 105–109.
- Rajendran, S. D., Wahab, S. N., Ling, Y. W., & Yun, L. S. (2018). The impact of logistics services on the e-shoppers' satisfaction. *International Journal of Supply Chain Management*, 7(5), 461–469.
- Riley, J. M., & Klein, R. (2019). How logistics capabilities retailers offer influence millennials' online purchasing attitudes and intentions. *Young Consumers*, 22(1), 131–151. <https://doi.org/10.1108/YC-12-2018-0889>
- Rita, P., Oliveira, T., & Farisa, A. (2019). The impact of e-service quality and customer satisfaction on customer behavior in online shopping. *Heliyon*, 5(10), e02690. <https://doi.org/10.1016/j.heliyon.2019.e02690>
- Saarijärvi, H., Sutinen, U.-M., & Harris, L. C. (2017). Uncovering Consumers' Returning Behaviour: A Study of Fashion E-commerce. *The International Review of Retail*, 27(3), 284–299. <https://doi.org/http://dx.doi.org/10.1080/09593969.2017.1314863>.
- Satria, R. (2021). Impact of Smartphone usage and internet connectivity on e-commerce adoption during the COVID-19 Pandemic in Indonesia. In *2021 9th International Conference on Cyber and IT Service Management (CITSM)*, 1–6.
- Schaupp, L. C. (2005). A Conjoint Analysis of Online Consumer Satisfaction. *Journal of Electronic Commerce Research*, 6(2), 95–111.
- Shah, M. H., Peikari, H. R., & Yasin, N. M. (2014). The determinants of individuals' perceived e-security: Evidence from Malaysia. *International Journal of Information Management*, 34(1), 48–57. <https://doi.org/10.1016/j.ijinfomgt.2013.10.001>
- Sheth, J. (2020). Impact of Covid-19 on consumer behavior: Will the old habits return or die? *Journal of Business Research Journal*, January, 280–283. <https://doi.org/10.1016/j.jbusres.2020.05.059>
- Srivastava, K., & Sharma, N. K. (2013). Service Quality, Corporate Brand Image, and Switching Behavior: The Mediating Role of Customer Satisfaction and Repurchase Intention. *Services Marketing Quarterly*, 34(4), 274–291. <https://doi.org/10.1080/15332969.2013.827020>
- Suharyono, H. (2020). The role of government policies and digital technology adoption in shaping e-commerce in Indonesia. In *2020 International Conference on Advanced Computer Science and Information Systems (ICACSIS)*, 164–169.
- Tandon, U., Kiran, R., & Sah, A. N. (2017). Customer Satisfaction as a mediator between website service quality and repurchase intention: An emerging economy case. *Service Science*, 9(2), 106–120. <https://doi.org/10.1287/serv.2016.0159>
- Uzir, M. U. H., Al Halbusi, H., Thurasamy, R., Thiam Hock, R. L., Aljaberi, M. A., Hasan, N., & Hamid, M. (2021). The effects of service quality, perceived value and trust in-home delivery service personnel on customer satisfaction: Evidence from a developing country. *Journal of Retailing and Consumer Services*, 63(April), 102721. <https://doi.org/10.1016/j.jretconser.2021.102721>
- Vakulenko, Y., Shams, P., Hellström, D., & Hjort, K. (2019). Service innovation in e-commerce last mile delivery: Mapping the e-customer journey. *Journal of Business Research*, 101(January), 461–468. <https://doi.org/10.1016/j.jbusres.2019.01.016>
- Walters, D. (2003). *Logistics, an introduction to supply chain management*. Palgrave MacMillan.
- Wang, S. (2018). The role of customer satisfaction in the relationship between post-purchase customer sentiment and online repurchase intention. *Journal of Interactive Marketing*, 44, 124–135.
- Wang, Y., Anderson, J., Joo, S. J., & Huscroft, J. R. (2020). The

- leniency of return policy and consumers' repurchase intention in online retailing. *Industrial Management and Data Systems*, 120(1), 21–39. <https://doi.org/10.1108/IMDS-01-2019-0016>
- Weisberg, J., Te'eni, D., & Arman, L. (2011). Past purchase and intention to purchase in e-commerce. *Internet Research*, 21(1), 82–96. <https://doi.org/10.1108/10662241111104893>
- Wijaya, D. C. (2021). Determinants of e-commerce adoption during the COVID-19 pandemic in Indonesia. In *2021 International Seminar on Application for Technology of Information and Communication (ISemantic)*, 179–183.
- Xiao, Y., Ren, X., Zhang, P., & Ketlhoafetse, A. (2020). The effect of service quality on foreign participants' satisfaction and behavioral intention with the 2016 Shanghai International Marathon. *International Journal of Sports Marketing and Sponsorship*, 21(1), 91–105. <https://doi.org/10.1108/IJSMS-04-2019-0037>
- Yuen, K. F., & Thai, V. V. (2015). Service quality and customer satisfaction in liner shipping. *International Journal of Quality and Service Sciences*, 7(2–3), 170–183. <https://doi.org/10.1108/IJQSS-02-2015-0024>
- Yu, H. S., Zhang, J. J., Kim, D. H., Chen, K. K., Henderson, C., Min, S. D., & Huang, H. (2014). Service Quality, Perceived Value, Customer Satisfaction, and Behavioral Intention Among Fitness Center Members Aged 60 Years and Over. *Social Behavior and Personality: An International Journal*, 42(5), 757–767. <https://doi.org/10.2224/sbp.2014.42.5.757>
- Yunisrina, A. (2021). The impact of smartphone affordability and internet infrastructure on e-commerce adoption in Indonesia during the COVID-19 pandemic. In *2021, the 9th International Conference on Information and Communication Technology (ICoICT)*, 1–5.